

Features

Model ARSB

- Slide in duct design — 49 sizes.
- Expanding duct seal for minimum leakage between unit and duct.
- Gasketed valve seal for minimum leakage.
- Damper blade shaft rotates in delrin bearings.
- Optional pneumatic or electric controls.
- Averaging type air flow sensor at inlet of unit.
- Low pressure drop
- Low sound levels.

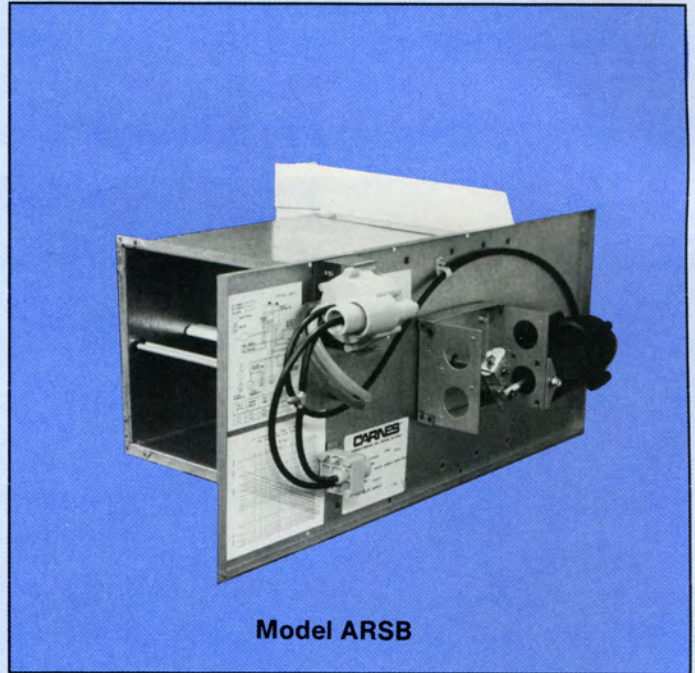

Model ARSB

Model ARRC

- Round inlet/outlet connections — 10 sizes.
- Rugged double wall galvanized steel construction.
- Thermally insulated casing.
- Gasketed valve seal for minimum leakage.
- Damper blade shaft rotates in delrin bearings.
- Optional pneumatic, electric or manual damper controls.
- Averaging type air flow sensor at inlet of unit.
- Low pressure drop.
- Low sound levels.
- Optional fire rated tubing.
- Optional coated insulation.
- Optional controls enclosure.

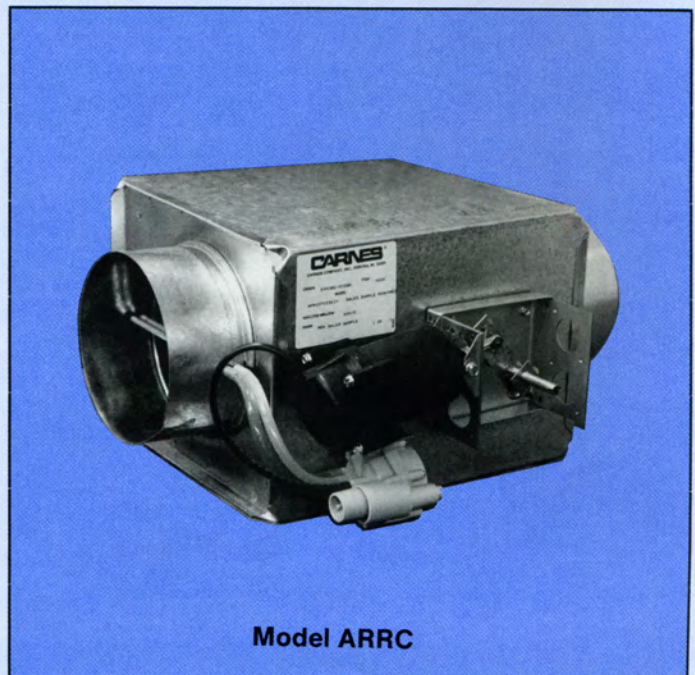

Model ARRC

CARNES - QUALITY YOU CAN COUNT ON!

Energy Conservation with VAV Retrofit

GENERAL

With the need to reduce energy consumed in a building's environmental control system, and to conserve ever dwindling energy resources, there is a growing interest in retrofitting existing constant volume systems into a variable air volume mode of operation. There are several factors which determine the success of this conversion process.

From the owner's standpoint the cost of conversion, system downtime with tenant inconvenience, actual savings realized, system and zone control, and tenant satisfaction, are all important factors in evaluating the success of the conversion.

To the tenant, zone control, air distribution in the zone and noise, are the criteria of success. These can be critical, because a well designed and installed constant volume system will usually meet the needs of the buildings tenants.

FAN SYSTEM

This catalog is primarily concerned with VAV conversion at the zone level, namely, air terminal units, and zone air distribution. To complete the conversion it is necessary to modify the system controls, fan performance and control, and possibly the central system configuration.

Several fan system conversions are:

- Variable volume damper on the discharge side of the fan.
- Variable inlet guide vanes in or near the fan inlet.
- Fan speed control.
- Fan blade angle change.

SYSTEM TYPES

The type of existing system, building perimeter design impositions, on the system, and zone requirements dictate the choice of approaches to the conversion to be taken.

LOW VELOCITY CONSTANT VOLUME REHEAT SYSTEM (Booster Coil Reheat)

This system has been very popular because of its simplicity, and once balanced properly, has good zone control performance characteristics. One major failing is that this approach has too few zones, with a single thermostat covering too large an area with varying loads. Barring this problem, the system can be easily converted to a variable volume system-with or without reheat-depending upon the zone requirements. For most interior zones, the reheat coils can and should be disconnected.

For perimeter zones, if the central system previously provided the heating to handle the entire perimeter heat loss, then the least costly approach is to keep the reheat coils active in these zones.

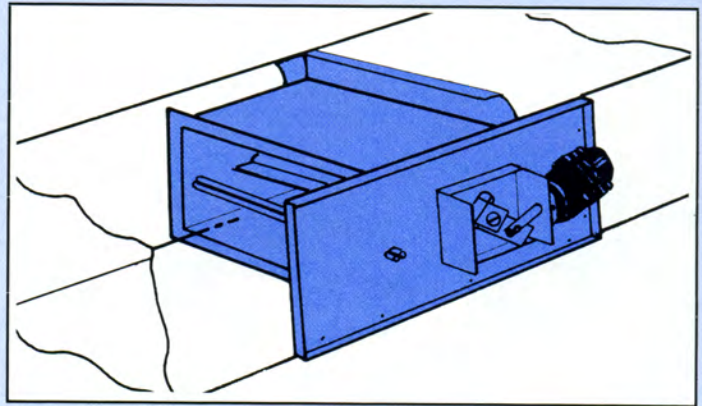

The unit used for this conversion, is the Model ARSB Retrofit Unit which is designed to be inserted into existing square or rectangular ductwork. With the same installation process taking only a short amount of time, minimum tenant inconvenience is experienced.

HIGH VELOCITY CONSTANT VOLUME REHEAT UNITS

The system with constant volume reheat terminals units can be easily converted to variable air volume by adding a retrofit unit upstream of the existing terminal unit which can now serve as a sound attenuator.

If reheat is required, existing and VAV retrofit controls can be sequenced to reduce the amount of primary air by 50 to 70 percent before activating the coil

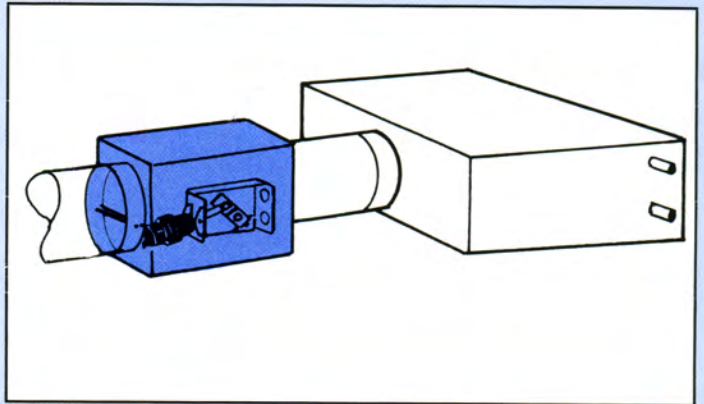

The unit for this conversion is the Model ARRC Retrofit Unit which replaces a short section of duct ahead of the terminal unit. The thermostat which formerly activated the reheat coil, can now be used to control the VAV retrofit unit and its coil when required.

DOUBLE DUCT CONSTANT VOLUME TERMINAL UNITS

Double duct systems can be converted to variable air volume by using a method similar to the reheat system.

Interior and exterior zones with adequate perimeter heating capabilities can have the hot duct capped off, and the retrofit unit installed in the cold duct. When warm air is required in exterior zones, two VAV retrofit units can be installed upstream of the existing double duct terminal unit.

The conversion shown below is for retrofitting both the hot and cold ducts. This type of conversion offers a wide variety of VAV control sequences from no mixing, to constant volume.

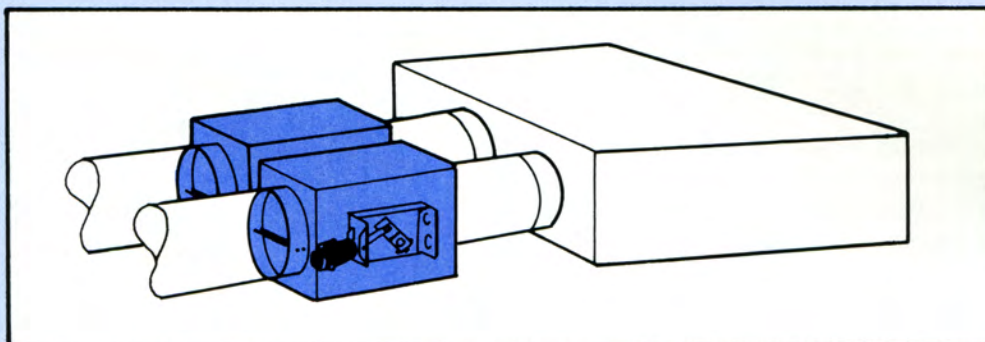

MODEL NUMBERING SYSTEM — Model ARRC Retrofit Unit for Round Duct

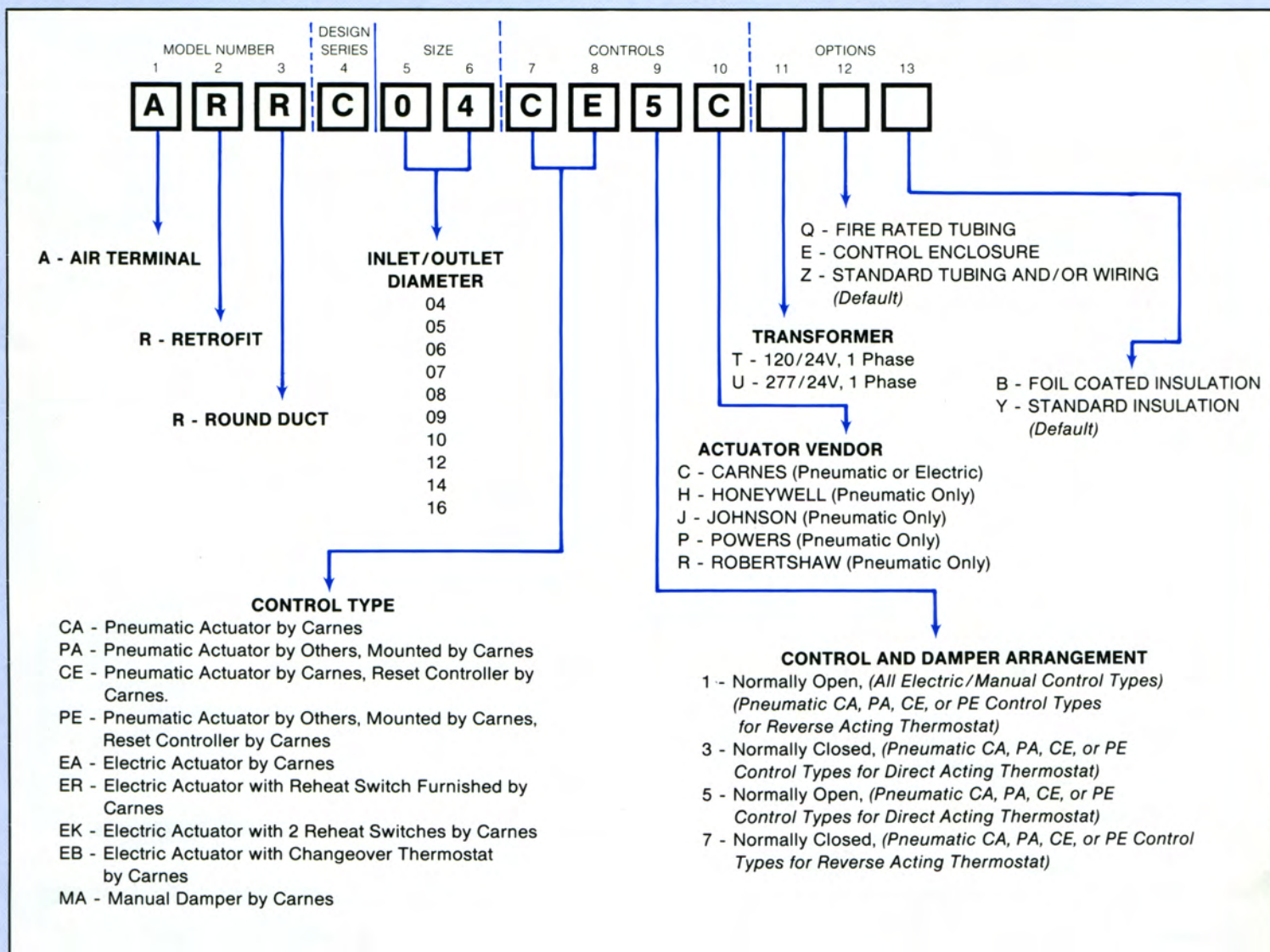

MODEL NUMBERING SYSTEM — Model ARSB Retrofit Unit for Square/Rectangular Duct

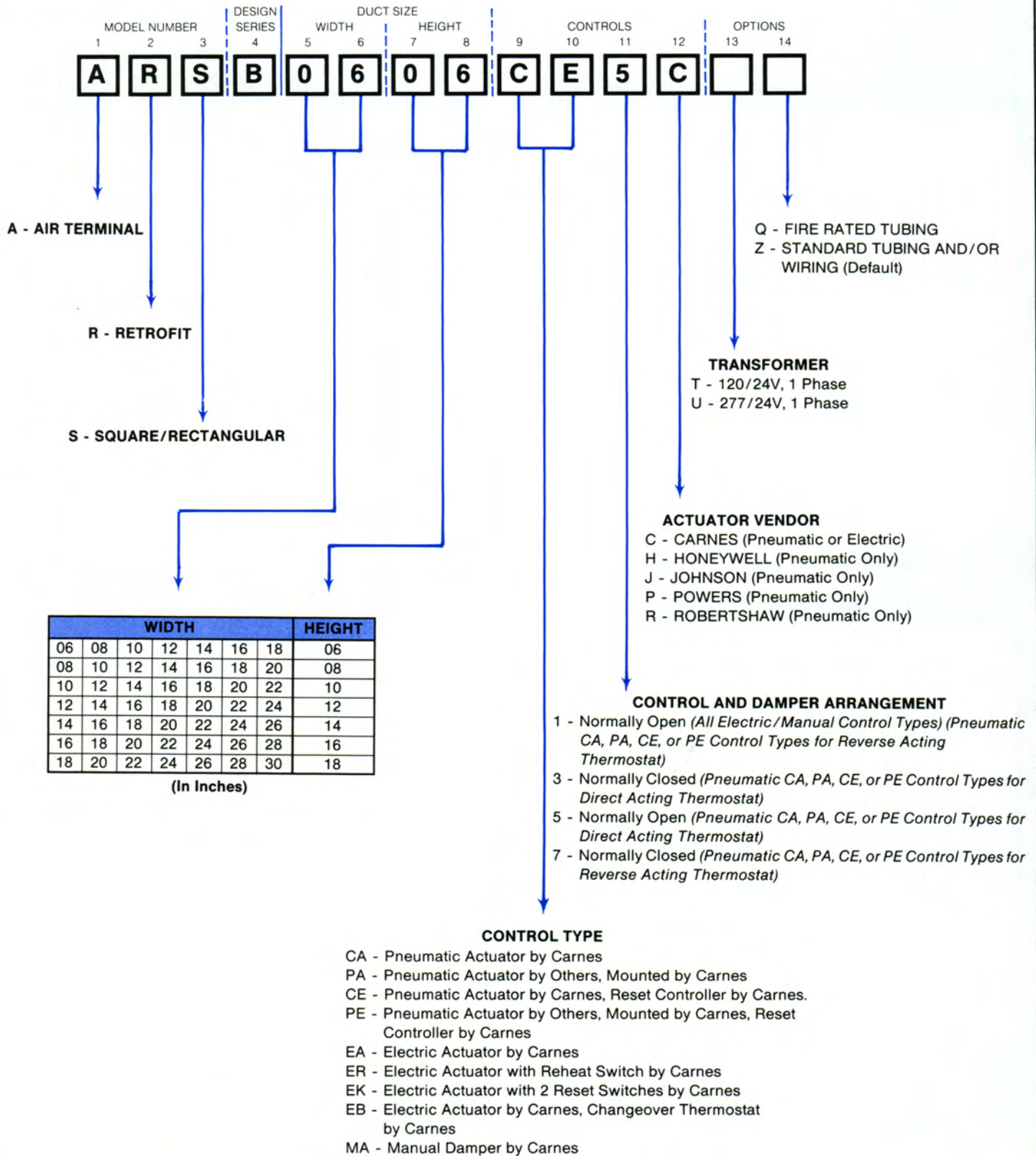

DIMENSIONAL DATA — Model ARRC

DUCT OPENING
(By Others)

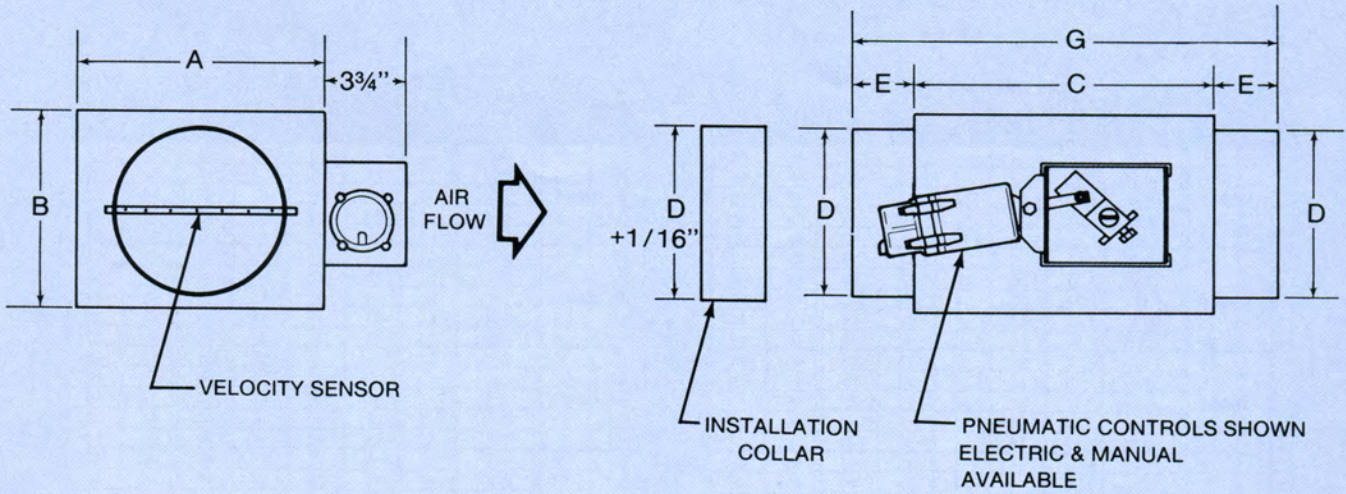

DIMENSIONS LISTED IN INCHES						
UNIT SIZE	A	B	C	D	E	G
04	10	8	11 ³ / ₄	4	2 ³ / ₈	16 ¹ / ₂
05	10	8	11 ³ / ₄	5	2 ³ / ₈	16 ¹ / ₂
06	10	8	11 ³ / ₄	6	2 ³ / ₈	16 ¹ / ₂
07	12	10	13 ³ / ₄	7	2 ³ / ₈	18 ¹ / ₂
08	12	10	13 ³ / ₄	8	2 ³ / ₈	18 ¹ / ₂
09	14	12	15 ³ / ₄	9	2 ³ / ₈	20 ¹ / ₂
10	14	12	15 ³ / ₄	10	2 ³ / ₈	20 ¹ / ₂
12	16	14	17 ³ / ₄	12	2 ³ / ₈	22 ¹ / ₂
14	18	16	19 ³ / ₄	14	2 ⁵ / ₈	25
16	20	18	21 ³ / ₄	16	2 ⁵ / ₈	27