

Mechanitrol Window/Perimeter Unit

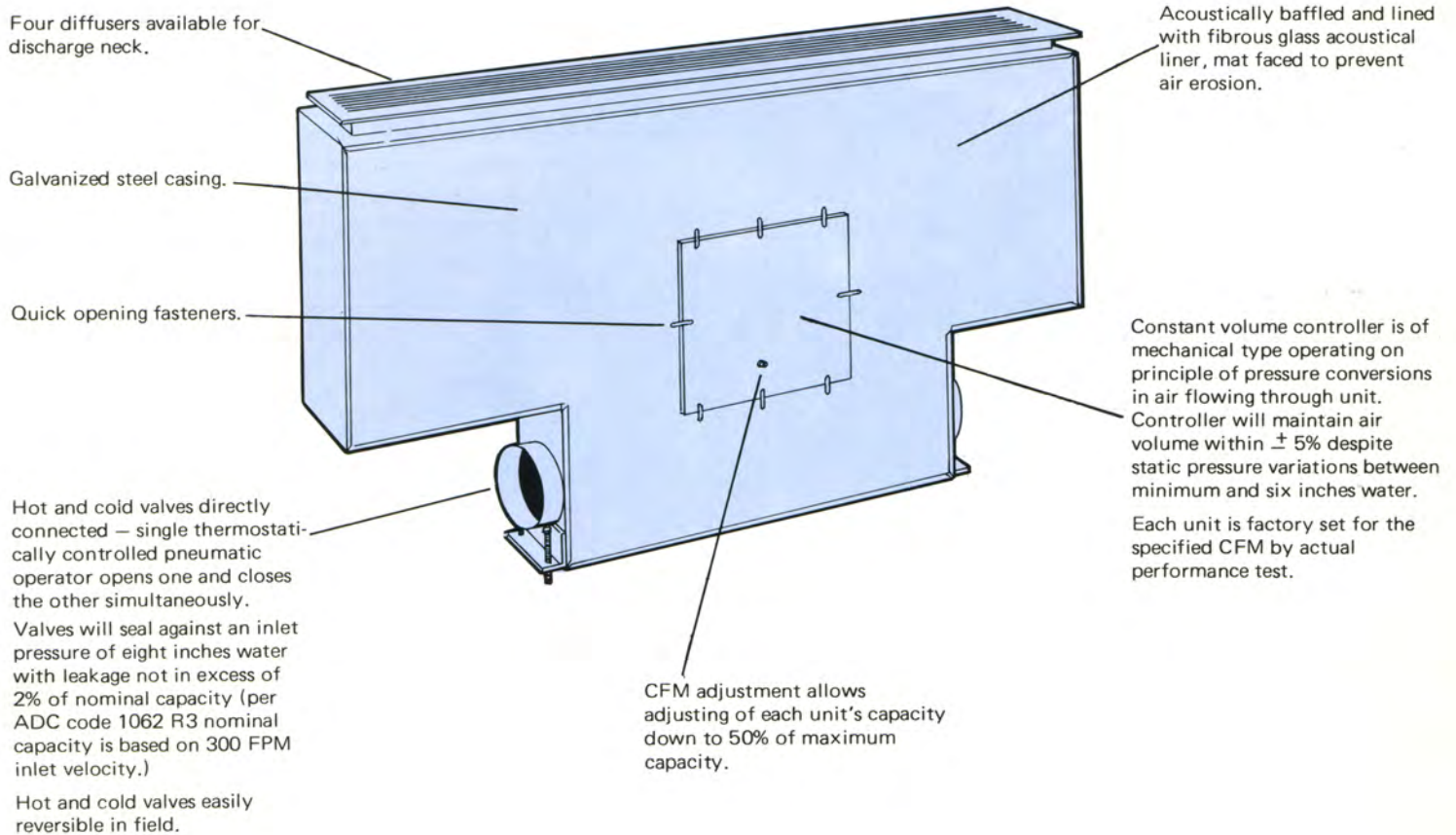

Designed for:

Window/perimeter units are designed for exterior zone heating and cooling, and are used primarily in climates where winters are severe. They are located under windows to entrain the cold air falling from the window surfaces with the primary air expelled from the outlet.

The unit is supplied complete with one of four styles of diffusers. These are the versatile, injection molded Modular; the extruded aluminum Curtaineaire; the extruded aluminum Curtainline; or the Linear, of steel with baked enamel finish.

Suggested Specifications:

TERMINAL CONTROL UNITS: Units shall be Carnes high velocity, dual duct, mechanical constant volume, acoustic terminal control units.

CAPACITIES: Each unit shall deliver the air capacity specified on the mechanical drawings with inlet velocity not in excess

of 1.2 inches water. The specified CFM shall be within the catalog limits of the unit. The low limit shall be at least 50% of the high limit. Units shall have cataloged performance ratings for CFM, static drop and sound power level.

CONSTANT VOLUME CONTROLLER: Controller shall be self-contained and maintain air volume within $\pm 5\%$ despite inlet static pressure variations between minimum and 6 inches water. Controller shall be factory set with air flow for CFM and shall have an exterior CFM dial and adjustment shaft to allow re-setting to any CFM within the limits specified under "Capacities" above.

VALVES: The temperature control valves shall be operable by one thermostatically controlled pneumatic operator. The valves shall be capable of sealing against an inlet pressure of 8 inches water with leakage less than 2% of

nominal capacity (nominal capacity based on 3000 FPM inlet velocity per Air Diffusion Council Code). Hot and cold valves are to be easily reversible in the field. The resilient sealing members shall be attached to the movable valve element rather than attached to the casing.

CASING: Casing shall be of galvanized steel construction, sealed to prevent leakage in excess of 3% of nominal capacity when all connections are sealed against pressure of 8 inches water upstream and 1 inch water downstream of volume controller.

INSULATION: The interior of the casing and baffles shall be covered with mat-faced fibrous glass acoustical liner with covered edges so no raw edges face air flow. Liner shall meet NFPA-90A.

SOUND POWER LEVEL: Units shall be rated in sound power level (PWL-NC Index) in decibels re 10^{-12} watt.

Performance and Dimensions Window Perimeter Unit

Size	CFM	Min. Spd.	SPD = 1"		SPD = 2"		SPD = 3"		SPD = 4"	
			PWL-NC Index	NC	PWL-NC Index	NC	PWL-NC Index	NC	PWL-NC Index	NC
WHCRB-424 WHCLB-424	100	.75	43	35	45	37	47	39	49	41
	125	.75	46	38	48	40	49	41	51	43
	150	.75	48	40	51	43	51	43	53	45
	175	.80	49	41	54	46	54	46	55	37
	200	1.0	49	41	57	49	57	49	58	50
WHCRB-536 WHCLB-536	150	.75	43	35	47	39	50	42	52	44
	175	.75	44	36	49	41	52	44	53	45
	200	.75	45	37	50	42	54	46	55	47
	225	.75	47	39	51	43	55	47	57	49
	250	.75	48	40	52	44	55	47	58	50
	275	.85	49	41	53	45	56	48	59	51
	300	1.0	50	42	55	47	56	48	59	51
WHCRB-648 WHCLB-648	200	.75	51	43	52	44	53	45	54	46
	225	.75	51	43	52	44	54	46	55	47
	250	.75	52	44	53	45	55	47	57	49
	275	.75	52	44	53	45	56	48	58	50
	300	.75	53	45	54	46	56	48	59	51
	325	.75	53	45	55	47	57	49	60	52
	350	.75	54	46	55	47	58	50	60	52
	375	.88	54	46	56	48	59	51	61	53
	400	1.0	54	46	56	48	60	52	61	53

Nominal Range Comparison: The chart below indicates the several units available at any given CFM. Detailed unit selections should be made from tables.

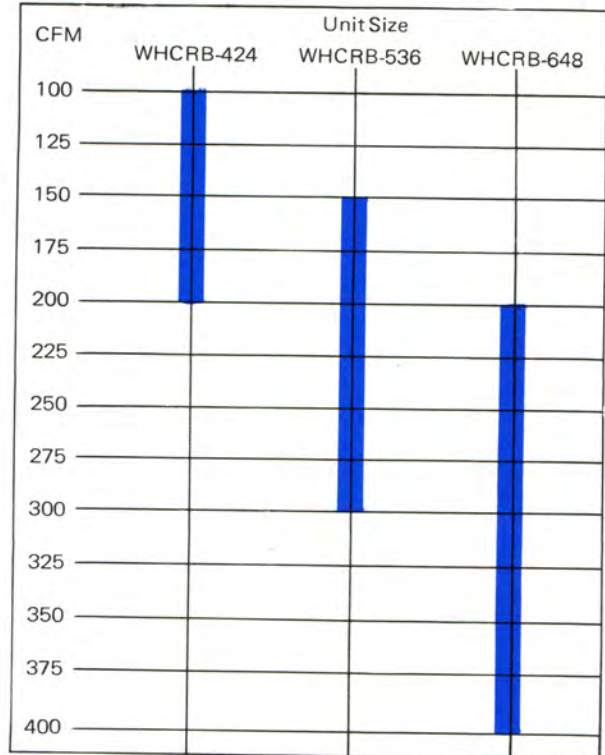

	Unit Size Number		
	WHCRB-424	WHCRB-536	WHCRB-648
	WHCLB-424	WHCLB-536	WHCLB-648
	Dimensions - Inches		
A	4	5	6
B	24-1/2	26-1/2	29-1/2
C	26	26	29
D	8	8	9
E	7-1/8	9-3/4	9-3/4
F	8-1/2	11-1/2	11-1/2
G	6-3/4	8-1/8	9-1/2
H	3-3/4	4-1/4	4-3/4
K	-	9-3/8	10-3/4
L	26	38	50
M	18-1/2	17-1/2	19-1/2
N	3/4	1-1/2	1-1/2
Sill Opening	6 x 24	6 x 36	6 x 48
	Diffuser Face Outside Dimensions		
Linear	8 x 26	8 x 38	8 x 50
Modular	6-3/4x24-3/4	6-3/4x36-3/4	6-3/4x48-3/4
Curtainaire	7 x 25	7 x 37	7 x 49
Curtainline	7-1/4x25-3/8	7-1/4x37-3/8	7-1/4x49-3/8

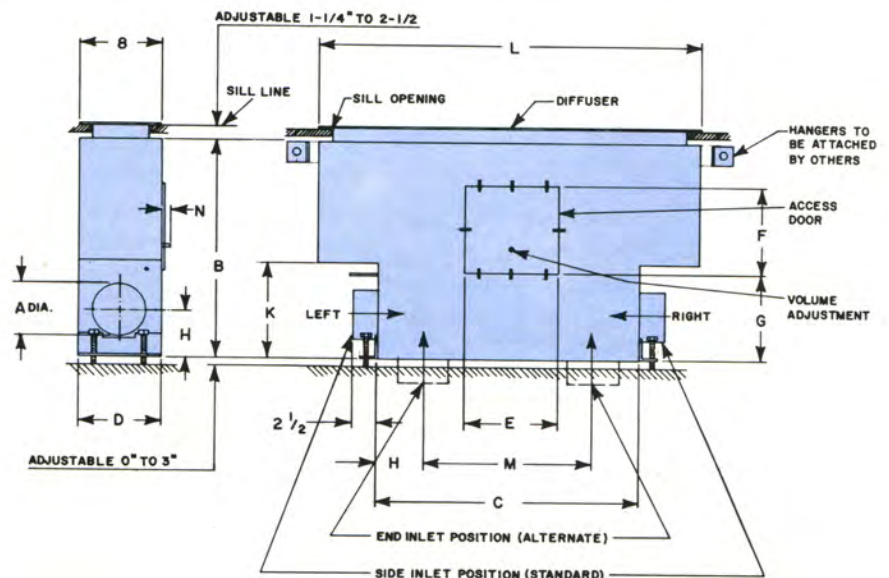

Model Numbering System

M	H	C	R	B	0012															
Type of Unit M = Dual Duct S = Single Duct w/o Valve T = Single Duct w/valve W = Window Perimeter Dual Duct D = Duct Mounted	Velocity H = High L = Low	Control M = Manual C = Constant Volume V = Reset Constant Volume	Hand Hand signifies side of normally open inlet: R = Right L = Left N = Not Applicable (Duct Mtd. Only)	Design Sequence B = Second Generation	Size from Catalog On window perimeter units size will be as follows: <table border="1"> <tr> <td>1</td> <td>5</td> <td>36</td> </tr> <tr> <td>Inlet Position</td> <td>Inlet Size</td> <td>Outlet Length</td> </tr> <tr> <td>1 = Side</td> <td>4</td> <td>24</td> </tr> <tr> <td>2 = End</td> <td>5</td> <td>36</td> </tr> <tr> <td></td> <td>6</td> <td>48</td> </tr> </table>	1	5	36	Inlet Position	Inlet Size	Outlet Length	1 = Side	4	24	2 = End	5	36		6	48
1	5	36																		
Inlet Position	Inlet Size	Outlet Length																		
1 = Side	4	24																		
2 = End	5	36																		
	6	48																		

Engineering Data

Sound Ratings:

PWL-NC index indicates the sound power level (PWL) in decibels, re 10^{-12} watt, radiated from the discharge end of the unit.

By definition, the PWL-NC index is a single number assigned to the PWL spectrum of a noise source indicating the minimum NC curve which will not be exceeded in any octave band (when subsequent attenuation is zero).

The NC (Noise Criteria, sound-pressure level in decibels re 0.0002 microbar) which will result in the room served will be less than the tabulated decibels, depending upon:

- The attenuation of the system downstream of the unit, due to branches, lined duct and bends, and end reflection.
- The attenuation of the room (RA) due to its acoustical characteristics.

NC values show the noise criteria which will result in the average room (RA = 8 db when PWL is re 10^{-12} watt) under two conditions:

0' is based on no acoustically lined duct between the unit and room outlet, and all the air is discharged from one properly sized outlet.

5' is based on five feet of acoustically lined duct (1" thick and 1.5 pcf density) between the unit and room outlet, and a maximum of 600 CFM per outlet. Rating "L" means that the NC will be less than 20 db.

Additional attenuation will be provided by more lengths of lined duct, lining of square elbows and tees, and more outlets per ATC unit. For further information see ASHRAE GUIDE & DATA BOOK.

PWL-NC index values were determined with no lined duct on outlet of unit.

Casing radiation: If units are installed exposed, rather than behind a ceiling or wall, add 3 db to the ratings of PWL-NC index and of NC with 0'. In this case, the addition of down-stream attenuation can effect a maximum decrease of only 3 db since the casing radiation noise will control the resultant room level.

Unit Sizes	Octave Band						
	2	3	4	5	6	7	8
1004	-2	0	-8	-12	-26	-29	-28
2004	+1	0	-8	-12	-24	-27	-27
0005	-2	0	-8	-15	-28	-28	-28
0006	+6	+4	0	-7	-19	-23	-24
0007	+8	+4	0	-6	-18	-20	-21
0008	+4	0	-6	-9	-21	-26	-28
0009	+4	0	-6	-16	-24	-30	-31
0010	+5	+3	0	-9	-19	-22	-26
0012	+3	0	-6	-15	-22	-23	-29
1414							
1620	+10	+6	+1	-4	0	-8	-13

The 0* point is where the spectrum and the NC curve are tangent. To draw a spectrum, pass a horizontal line thru the tangent point and apply the plus or minus numbers to this line.

Sound tests per ASHRAE Standard 36B-63.

Static Pressure:

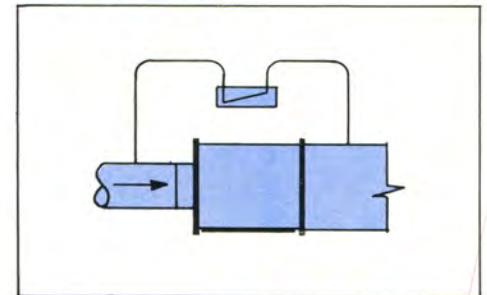

SPD = STATIC PRESSURE DROP (Inches of water) measured across the inlet and discharge openings of the unit.

The minimum SPD required is 0.75 inches. The maximum SPD rated is 8.0 inches.

The total minimum SP required at the inlet of the controller for the required CFM is the sum of 0.75 plus the resistances of the downstream ductwork and outlets.