

Imperial [IP] Dimensions
Metric (SI) in Parentheses

CARNES COMPANY 448 S. Main St., P. O. Box 930040, Verona, WI 53593-0040 Phone: (608)845-6411 Fax: (608)845-6504 www.carnes.com

SQUARE

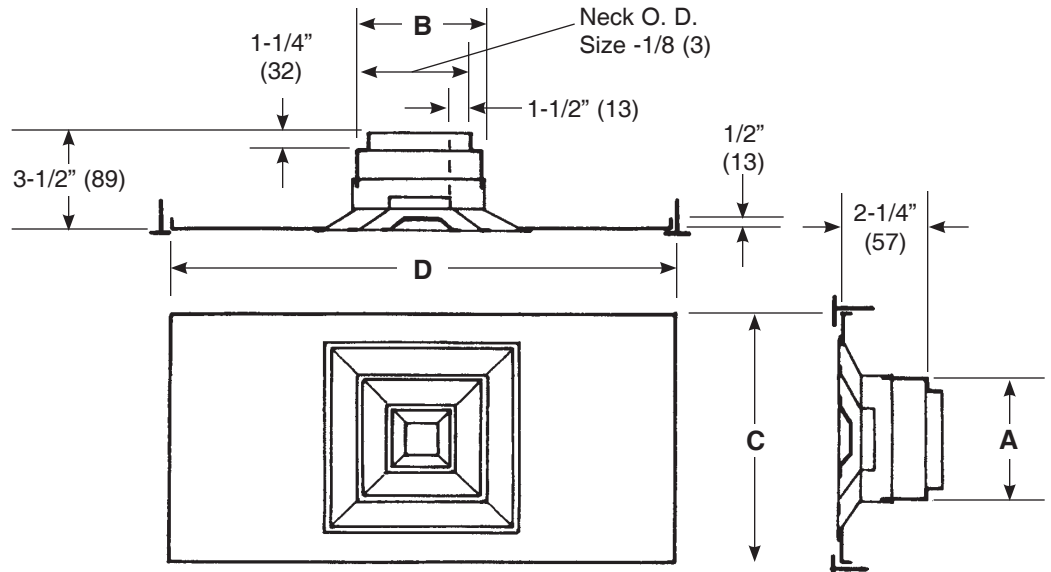
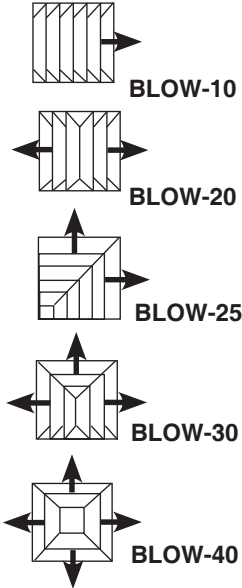

DIMENSIONS LISTED IN INCHES (Millimeters)

Unit Size	Size A x B	PANEL - C x D				
		11-3/4x11-3/4 (229x229)	11-3/4x23-3/4 (229x603)	23-3/4x23-3/4 (603x603)	23-3/4x47-3/4 (603x1212)	47-3/4x47-3/4 (1212x1212)
4 (102)	6x6 (152x152)	X	X	X	X	X
5 (127)	6x6 (152x152)	X	X	X	X	X
6 (152)	6x6 (152x152)	X	X	X	X	X
6 (152)	9x9 (229x229)	①	X	X	X	X
8 (203)	9x9 (229x229)	①	X	X	X	X
9 (229)	9x9 (229x229)	①	X	X	X	X
10 (254)	12x12 (305x305)	—	—	X	X	X
12 (305)	12x12 (305x305)	—	—	X	X	X
12 (305)	15x15 (381x381)	—	—	X	X	X
14 (356)	15x15 (381x381)	—	—	X	X	X
15 (381)	15x15 (381x381)	—	—	X	X	X
16 (406)	18x18 (457x457)	—	—	X	X	X
18 (457)	18x18 (457x457)	—	—	X	X	X
18 (457)	21x21 (533x533)	—	—	②	X	X
20 (508)	21x21 (533x533)	—	—	②	X	X
21 (533)	21x21 (533x533)	—	—	②	X	X
22 (559)	24x24 (610x610)	—	—	—	—	X
24 (610)	24x24 (610x610)	—	—	—	—	X

Notes:

- Order standard SKEA which has an outside of 11-13/16" x 11-13/16" (229x229).
- Order standard SKEA which has an outside of 23-13/16" x 23-13/16" (603x603).
- Standard finish is Carnes No. 11 White electrocoat.

For other sizes and panel sizes contact Carnes Company Sales Department.

X = Sizes Available

ADJUSTMENT DETAIL

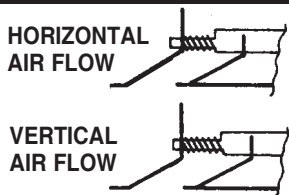

Two spring loaded pins, four pin suspension to ceiling plate. Removable and interchangeable center core assembly.