

*IP Units (SI Metric on Reverse)*

CARNES COMPANY, 448 S. Main St., P. O. Box 930040, Verona, WI. 53593-0040 Phone: 608/845-6411 Fax: 608/845-6470 carnes@carnes.com http://www.carnes.com

#### SQUARE

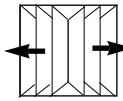

**BLOW 20**

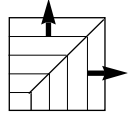

**BLOW 25**

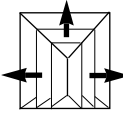

**BLOW 30**

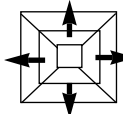

**BLOW 40**

#### RECTANGULAR

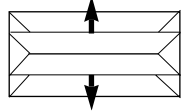

**BLOW 21**

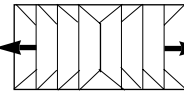

**BLOW 22**

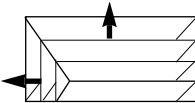

**BLOW 26**

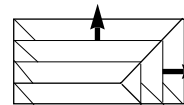

**BLOW 27**

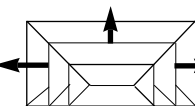

**BLOW 31**

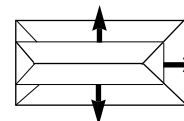

**BLOW 32**

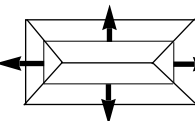

**BLOW 41**

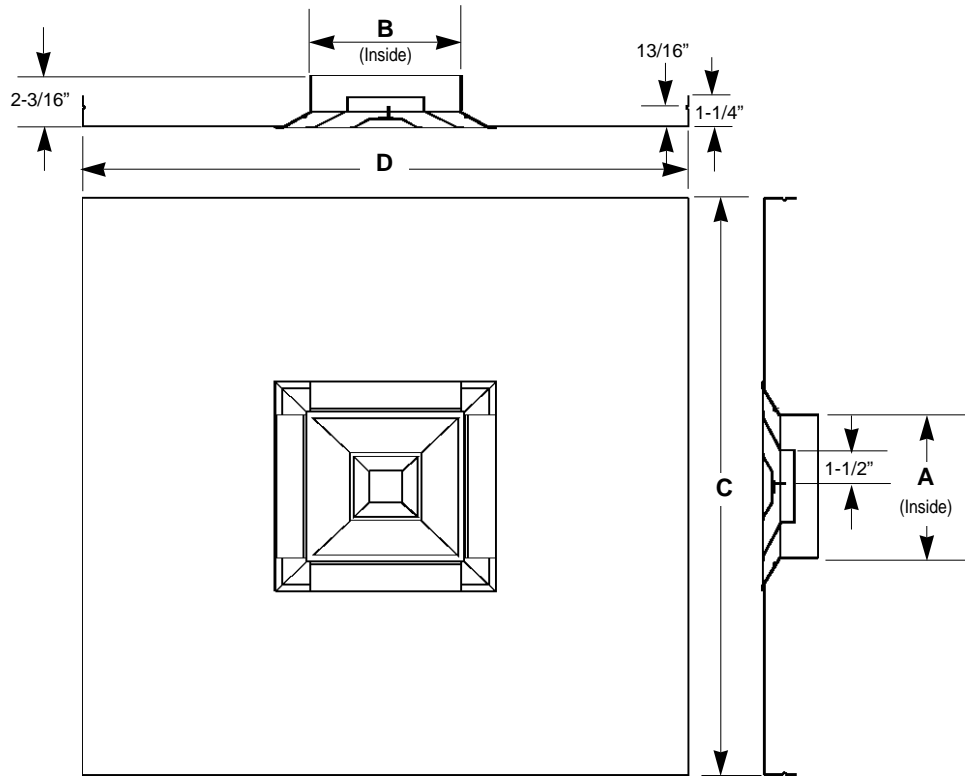

#### ADJUSTMENT

HORIZONTAL AIR FLOW

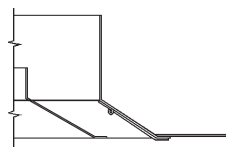

VERTICAL AIR FLOW

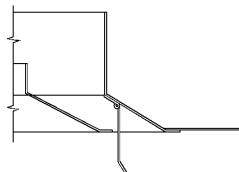

Remember that  
Dimensions A & B are the  
inside dimensions of the inlet.  
The inlet is sized to fit over  
the duct.

#### DIMENSIONS LISTED IN INCHES

Inlet Size	Panel	Panel	Panel
A x B	C x D	C x D	C x D
6 x 6	12 x 12	12 x 24	24 x 24
6 x 9	12 x 12	12 x 24	24 x 24
6 x 12	—	12 x 24	24 x 24
6 x 15	—	12 x 24	24 x 24
6 x 18	—	12 x 24	24 x 24
6 x 21	—	12 x 24	24 x 24
9 x 9	12 x 12	12 x 24	24 x 24
9 x 12	—	12 x 24	24 x 24
9 x 15	—	12 x 24	24 x 24
9 x 18	—	12 x 24	24 x 24
9 x 21	—	12 x 24	24 x 24
12 x 12	—	—	24 x 24
12 x 15	—	—	24 x 24
12 x 18	—	—	24 x 24
12 x 21	—	—	24 x 24
15 x 15	—	—	24 x 24
15 x 18	—	—	24 x 24
15 x 21	—	—	24 x 24
18 x 18	—	—	24 x 24
18 x 21	—	—	24 x 24
21 x 21	—	—	24 x 24

*SI Metric Units (IP on Reverse)*

CARNES COMPANY, 448 S. Main St., P. O. Box 930040, Verona, WI. 53593-0040 Phone: 608/845-6411 Fax: 608/845-6470 carnes@carnes.com http://www.carnes.com

#### SQUARE

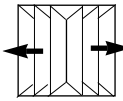

**BLOW 20**

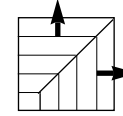

**BLOW 25**

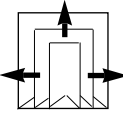

**BLOW 30**

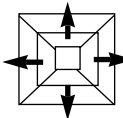

**BLOW 40**

#### RECTANGULAR

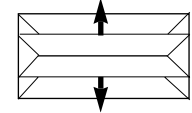

**BLOW 21**

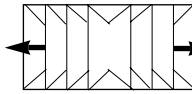

**BLOW 22**

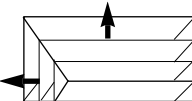

**BLOW 26**

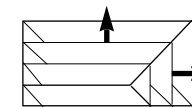

**BLOW 27**

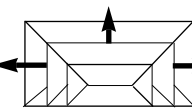

**BLOW 31**

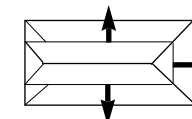

**BLOW 32**

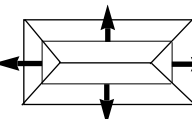

**BLOW 41**

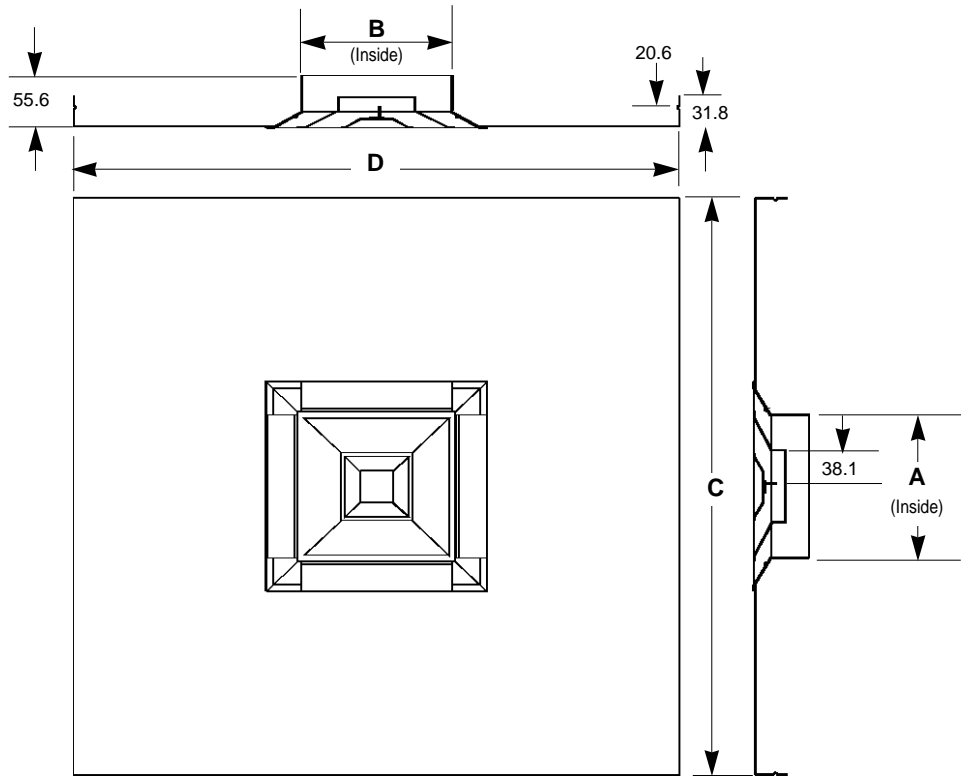

#### ADJUSTMENT

HORIZONTAL AIR FLOW

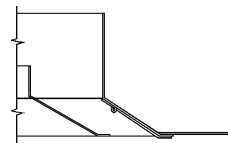

VERTICAL AIR FLOW

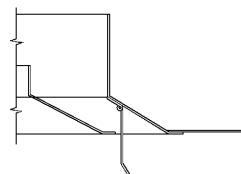

Remember that  
Dimensions A & B are the  
inside dimensions of the inlet.  
The inlet is sized to fit over  
the duct.

#### DIMENSIONS LISTED IN MILLIMETERS

Inlet Size	Panel	Panel	Panel
A x B	C x D	C x D	C x D
152 x 152	305 x 305	305 x 610	610 x 610
152 x 229	305 x 305	305 x 610	610 x 610
152 x 305	—	305 x 610	610 x 610
152 x 381	—	305 x 610	610 x 610
152 x 457	—	305 x 610	610 x 610
152 x 533	—	305 x 610	610 x 610
229 x 229	305 x 305	305 x 610	610 x 610
229 x 305	—	305 x 610	610 x 610
229 x 381	—	305 x 610	610 x 610
229 x 457	—	305 x 610	610 x 610
229 x 533	—	305 x 610	610 x 610
305 x 305	—	—	610 x 610
305 x 381	—	—	610 x 610
305 x 457	—	—	610 x 610
305 x 533	—	—	610 x 610
381 x 381	—	—	610 x 610
381 x 457	—	—	610 x 610
381 x 533	—	—	610 x 610
457 x 457	—	—	610 x 610
457 x 533	—	—	610 x 610
533 x 533	—	—	610 x 610