

Imperial [IP] Dimensions Metric (SI) In Parentheses

CARNES COMPANY, Verona, WI. Phone: 608/845-6411 Fax: 608/845-6470 E-Mail: carnes@carnes.com www.carnes.com

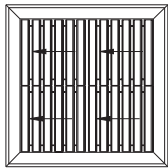

1-Way

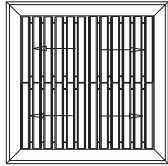

2-Way Opposite

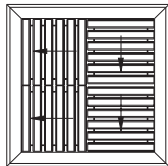

2-Way Corner

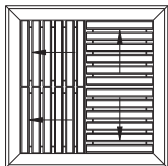

3-Way

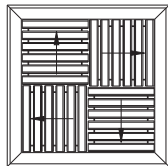

4-Way

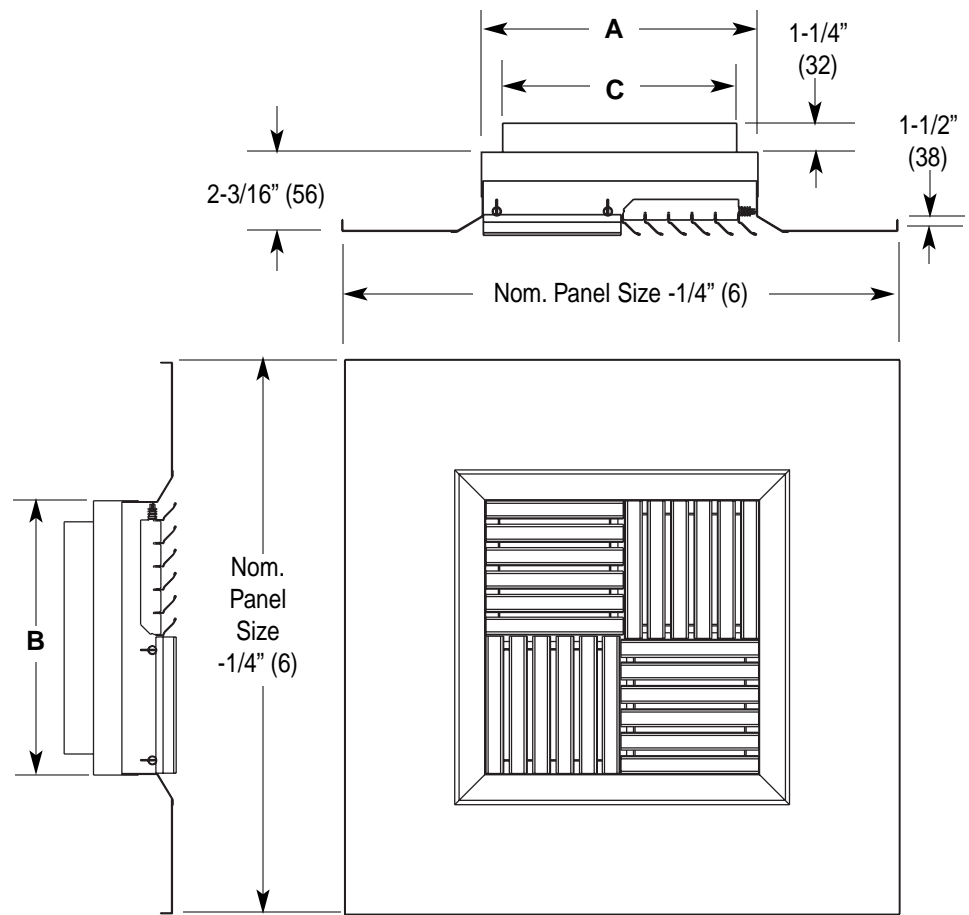

Notes:

1. Construction is aluminum.
2. Standard finish is electrocoat acrylic baked enamel. Other finishes are available on request.
3. Standard color is #11 Bright White. Other colors are available on request.
4. Metric dimensions are in millimeters.
5. Inlet is undersized by 1/8" (3) to fit inside duct.

Nominal Square Neck Size (A x B)	Available Round Inlet Nominal Size (C)	Available Nominal Panel Sizes
6" x 6" (152 x 152)	5" (127), 6" (152)	12" x 12", 12" x 24", 24" x 24", 24" x 48"
8" x 8" (203 x 203)	6" (152), 8" (203)	12" x 12", 12" x 24", 24" x 24", 24" x 48"
10" x 10" (254 x 254)	8" (203), 10" (254)	24" x 24", 24" x 48"
12" x 12" (305 x 305)	10" (254), 12" (305)	24" x 24", 24" x 48"
14" x 14" (356 x 356)	12" (305), 14" (356)	24" x 24", 24" x 48"
16" x 16" (406 x 406)	14" (356), 16" (406)	24" x 24", 24" x 48"
18" x 18" (457 x 457)	16" (406), 18" (457)	24" x 24", 24" x 48"
20" x 20" (508 x 508)	18" (457), 20" (508)	24" x 24", 24" x 48"