

Imperial [IP] Dimensions
Metric (SI) In Parentheses

Steel Square/Rectangular Opposed Blade Damper with Pull-Cord Operator Option

CARNES COMPANY, 448 S. Main St., P. O. Box 930040, Verona, WI. 53593-0040 Phone: 608/845-6411 Fax: 608/845-6470 E-Mail: carnes@carnes.com www.carnes.com

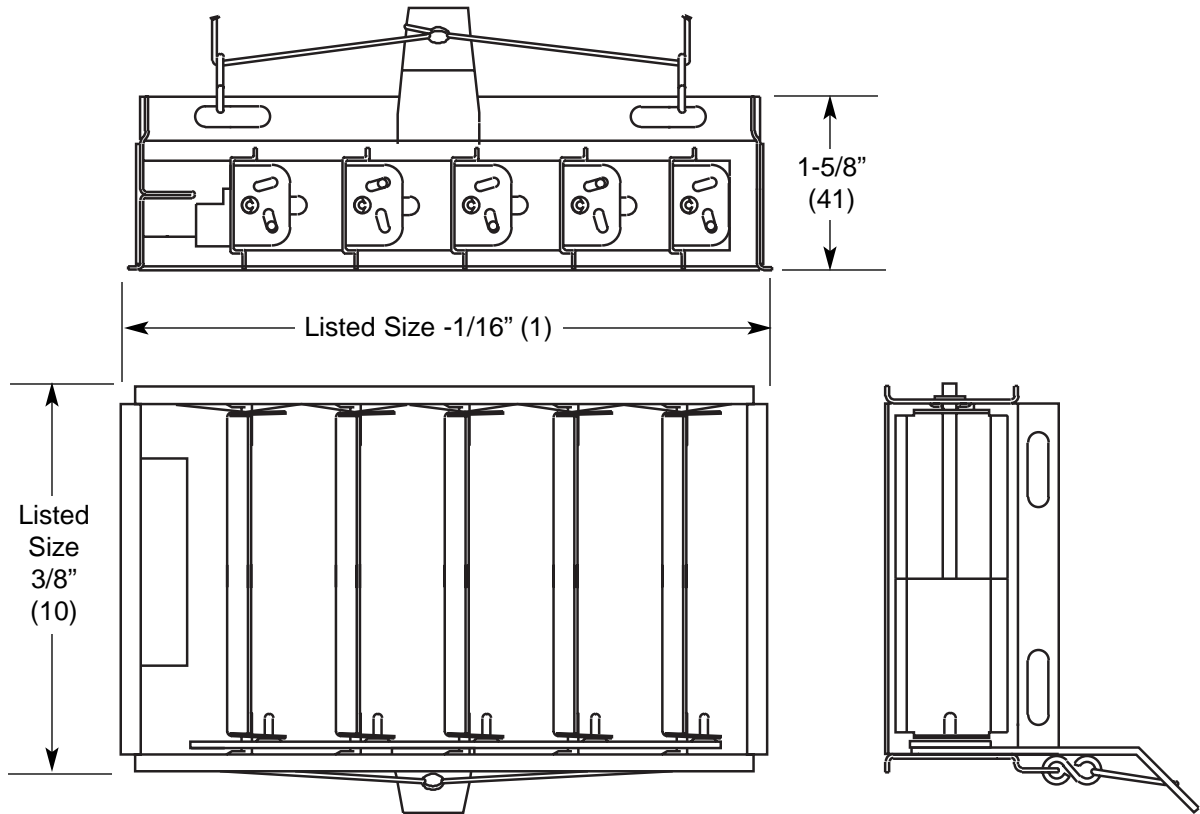

Note:

1. Construction is formed steel.
2. Finished is electrogalvanized.
3. Blades can be aligned along the long or short dimension.
4. Maximum size is 12" ((305) x 18" (457).
5. Damper is operated by pulling on opposing cords.