

**IP [English] Dimensions**  
*SI (Metric) In Parentheses*

CARNES COMPANY, 448 S. Main St., P. O. Box 930040, Verona, WI. 53593-0040 Phone: 608/845-6411 Fax: 608/845-6504 E-Mail: carnes@carnes.com www.carnes.com

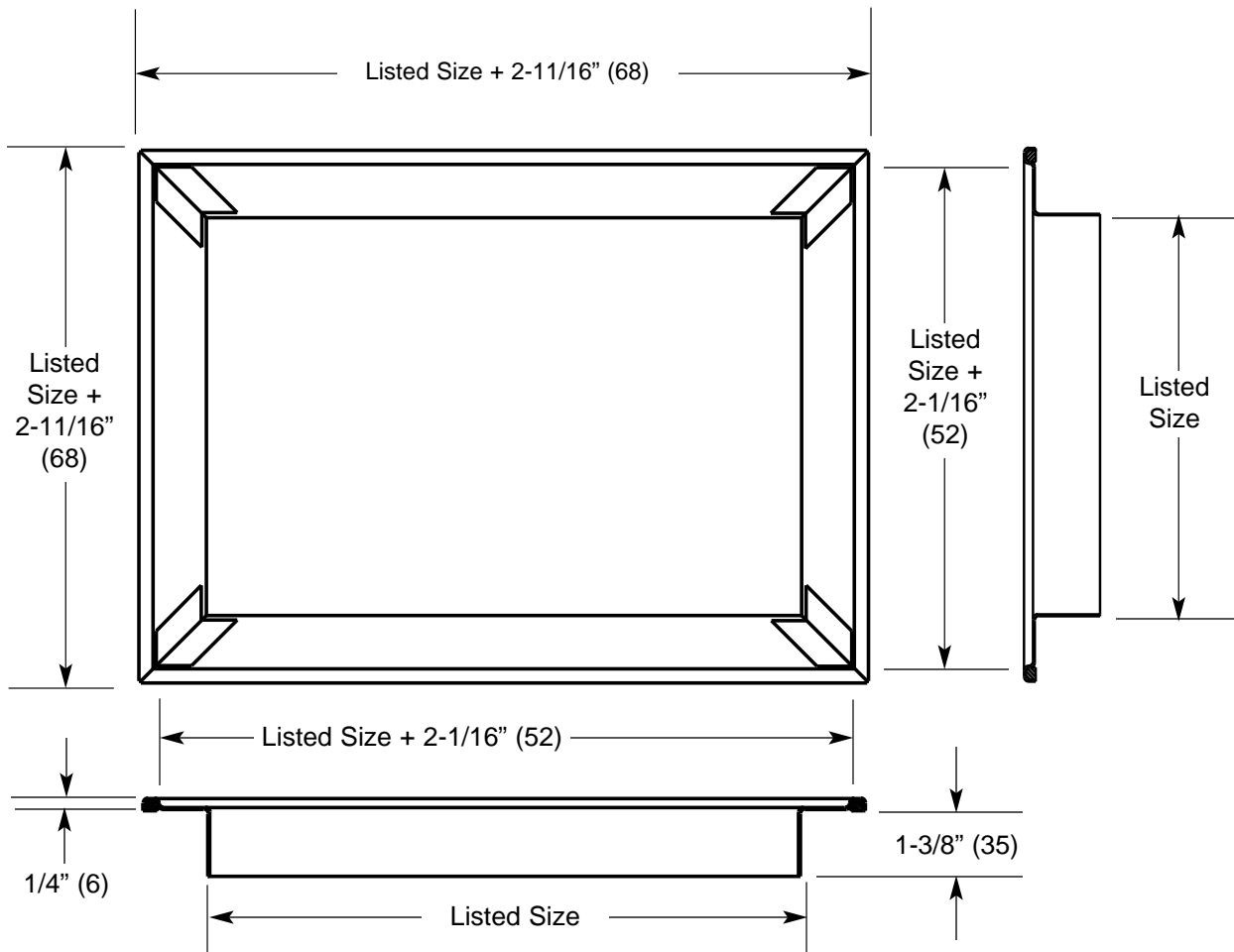

Can be mounted flush to the wall surface, and act as a plaster stop.

Can be mounted on the surface of the wall.

**Notes:**

1. Construction of Model RXSA is cold rolled steel.
2. Construction of Model RXLA is Type 304 stainless steel.
3. Polyurethane gasket is supplied as standard.
4. The standard finish for Model RXSA is electrocoat acrylic baked enamel.
5. The standard color for Model RXSA is #11 Bright White.
6. The standard finish and color for Model RXLA is #22 Satin Polish with one coat of clear lacquer.
7. Metric (SI) dimensions are in millimeters.
8. Minimum size is 6" x 4" (152 x 102).
9. Maximum standard size is 48" x 36" (1219 x 914).
10. Larger sizes are available upon request.
11. Sizes larger than 48" x 36" are shipped broken down for field assembly.
12. Recommended ceiling opening is nominal size plus 1/8" (3).