

**Imperial [IP] Dimensions
Metric (SI) in Parentheses**

CARNES COMPANY 448 S. Main St., P. O. Box 930040, Verona, WI 53593-0040 Phone: (608)845-6411 Fax: (608)845-6504 www.carnes.com

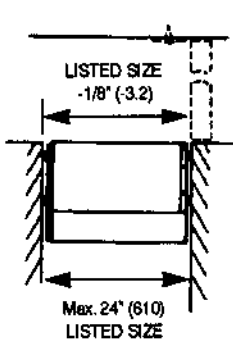

STYLE NO. 1

NOTE: Standard Finish #04 Gray Electrocoat Enamel.

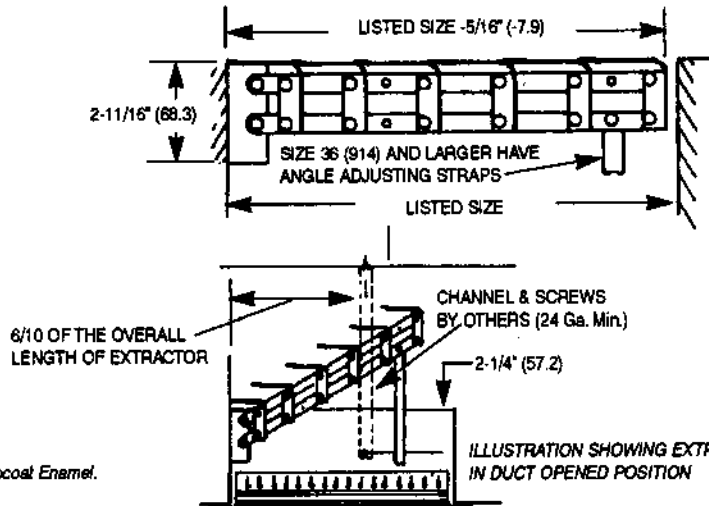

NOTES:

1. Maximum blade length is 24" (610).
2. Maximum unit size is 60"x24" (1524x610)
3. Construction is cold rolled steel, painted.

STYLE NO. 2

NOTE: Standard Finish #04 Gray Electrocoat Enamel.

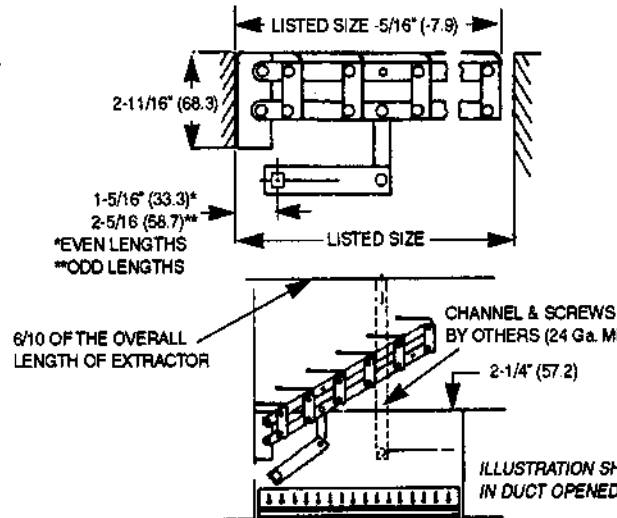
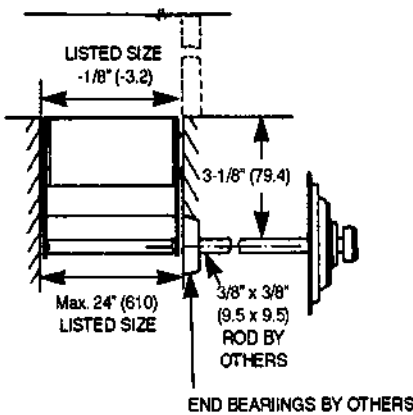

NOTES:

1. Maximum blade length is 24" (610).
2. Maximum unit size is 36"x24" (914x610)
3. Construction is cold rolled steel, painted.

STYLE NO. 3

NOTE: Standard Finish #04 Gray Electrocoat Enamel.

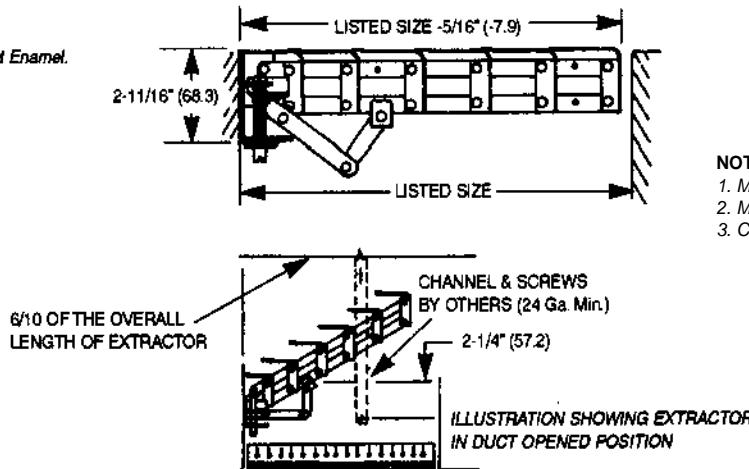
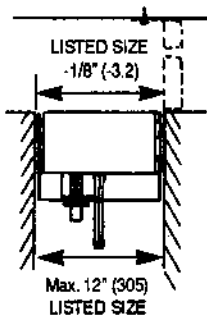

NOTES:

1. Maximum blade length is 12" (305).
2. Maximum unit size is 24"x12" (610x305)
3. Construction is cold rolled steel, painted.

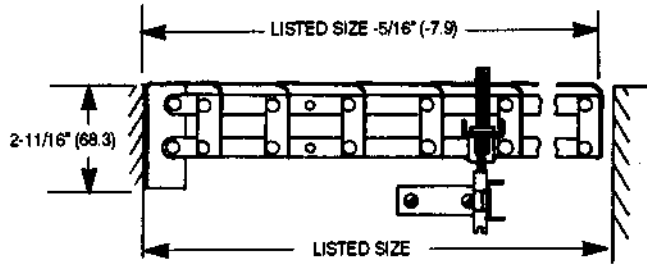
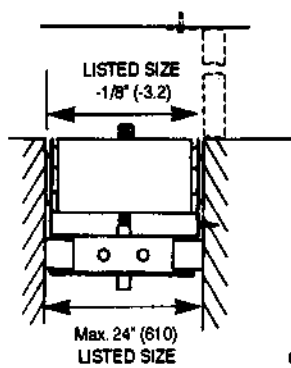

- NOTES:
1. Maximum blade length is 24" (610).
 2. Maximum unit size is 60"x24" (1524x610)
 3. Construction is cold rolled steel, painted.

6/10 OF THE OVERALL
LENGTH OF EXTRACTOR

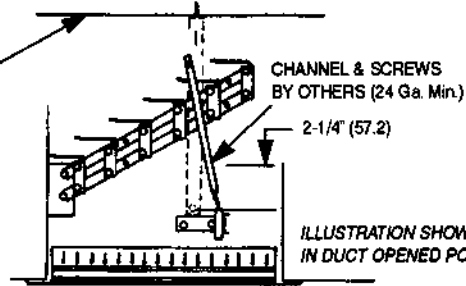

STYLE NO. 4

NOTE: Standard Finish #04 Gray Electrocoat Enamel.

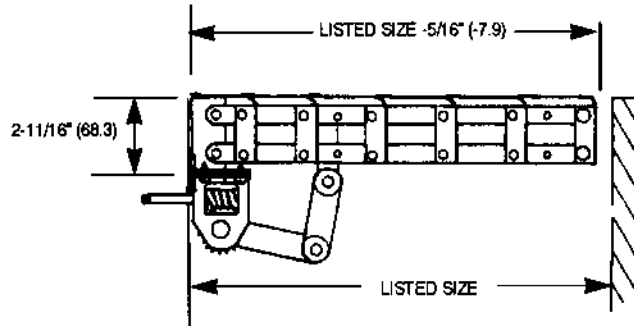
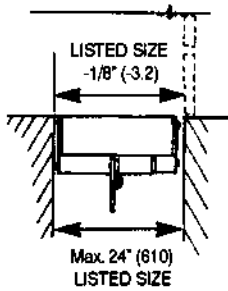

- NOTES:
1. Maximum blade length is 24" (610).
 2. Maximum unit size is 60"x24" (1524x610)
 3. Construction is cold rolled steel, painted.

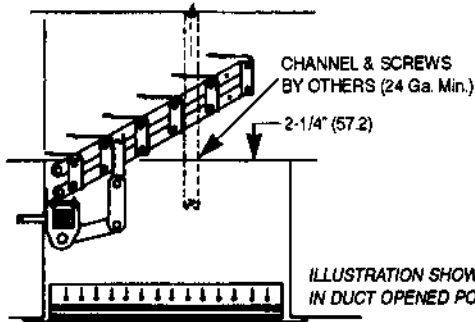

STYLE NO. 5

NOTE: Standard Finish #04 Gray Electrocoat Enamel.