

Imperial [IP] Dimensions Metric (SI) In Parentheses

CARNES COMPANY, 448 S. Main St., P. O. Box 930040, Verona, WI. 53593-0040 Phone: 608/845-6411 Fax: 608/845-6504 E-Mail: carnes@carnes.com www.carnes.com

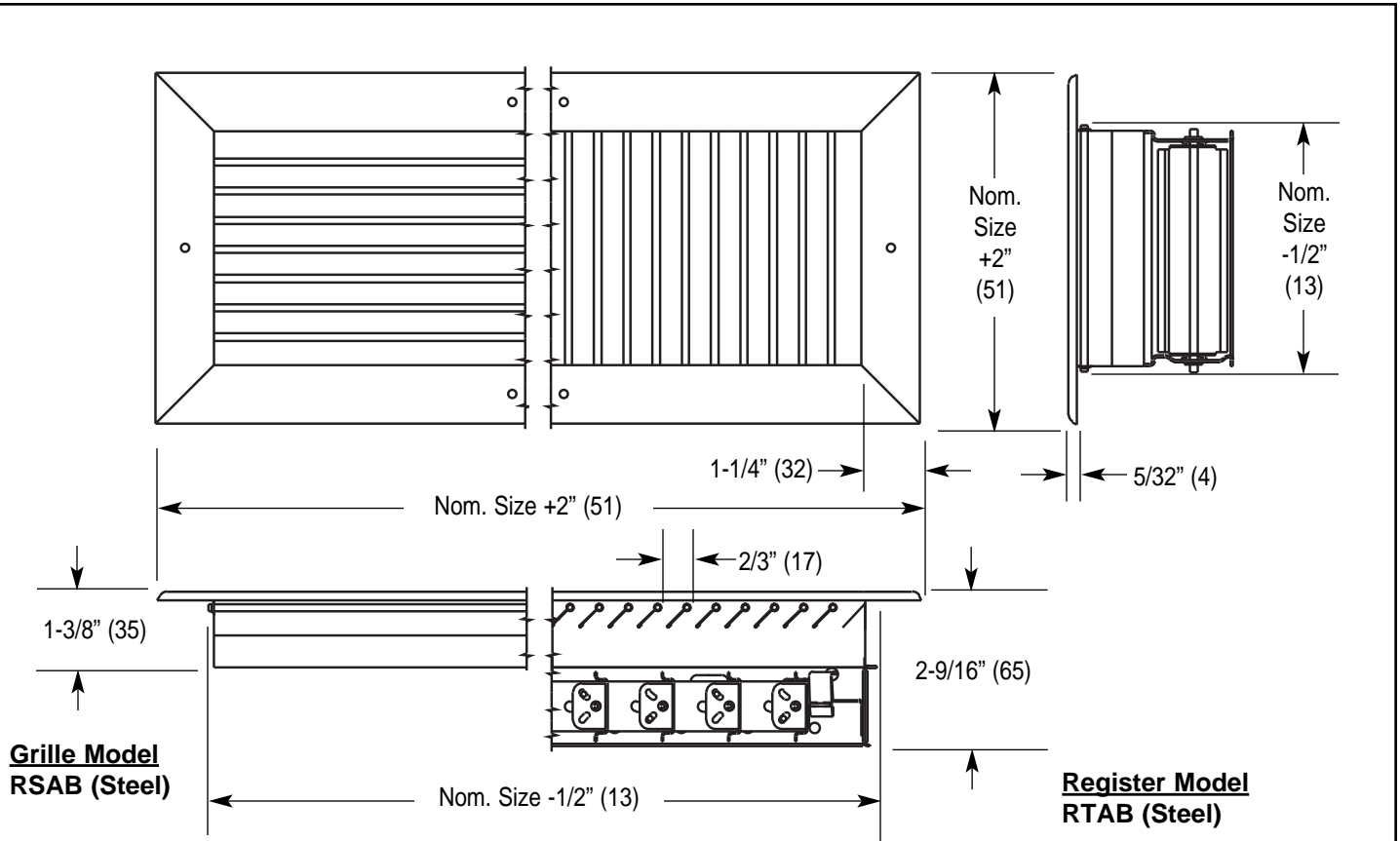

Notes:

1. Standard screws are #6 x 1-1/4" (32) phillips trusshead screws.
2. Polyurethane foam gasket around edge of frame is available on request.
3. The standard finish is electrocoat acrylic baked enamel. Other finishes available on request.
4. The standard color is #11 Bright White. Other colors are available on request.
5. Blades can be aligned either horizontally or vertically, and are fixed at 45° deflection.
6. Center mullion is used for blade lengths exceeding 24" (610) nominal size on steel models RSAB and RTAB.
7. Center mullion is used for blade lengths exceeding 18" (457) nominal size on aluminum models RAAB, RWAB and RNAB.
8. Standard sizing is in even inch increments in both dimensions. Odd inch and fractional sizing [in 1/8" (3) increments] is available on request.
9. This product is covered by U. S. Patent #5,771,647.
10. Steel damper is Model RXEA opposed blade damper.
11. The standard operator on the damper takes a medium size flat-blade screwdriver.
12. Maximum size shown is the maximum single panel size.

Panels can be joined for larger sizes.

13. Metric dimensions are given in millimeters.

Lay-In	Size	Order Size	OD Size
14.	12"x12"	9-3/4"x9-3/4"	11-3/4"x11-3/4"
15.	24"x12"	21-3/4"x9-3/4"	23-3/4"x11-3/4"
16.	24"x24"	21-3/4"x21-3/4"	23-3/4"x23-3/4"
17.	24"x48"	21-3/4"x45-3/4"	23-3/4"x47-3/4"

Model	Construction	Damper	Blade Alignment	Minimum W x H	Maximum W x H
RSABH	Steel	None	Horizontal	4" x 4" (102 x 102)	36" x 36" (914 x 914)
RSABV	Steel	None	Vertical		
RTABH	Steel	Steel	Horizontal		
RTABV	Steel	Steel	Vertical		