

IP [English] Dimensions
 SI (Metric) on Reverse Side

CARNES COMPANY 448 S. Main St., P. O. Box 930040, Verona, WI 53593-0040 Phone: (608)845-6411 Fax: (608)845-6504 www.carnes.com

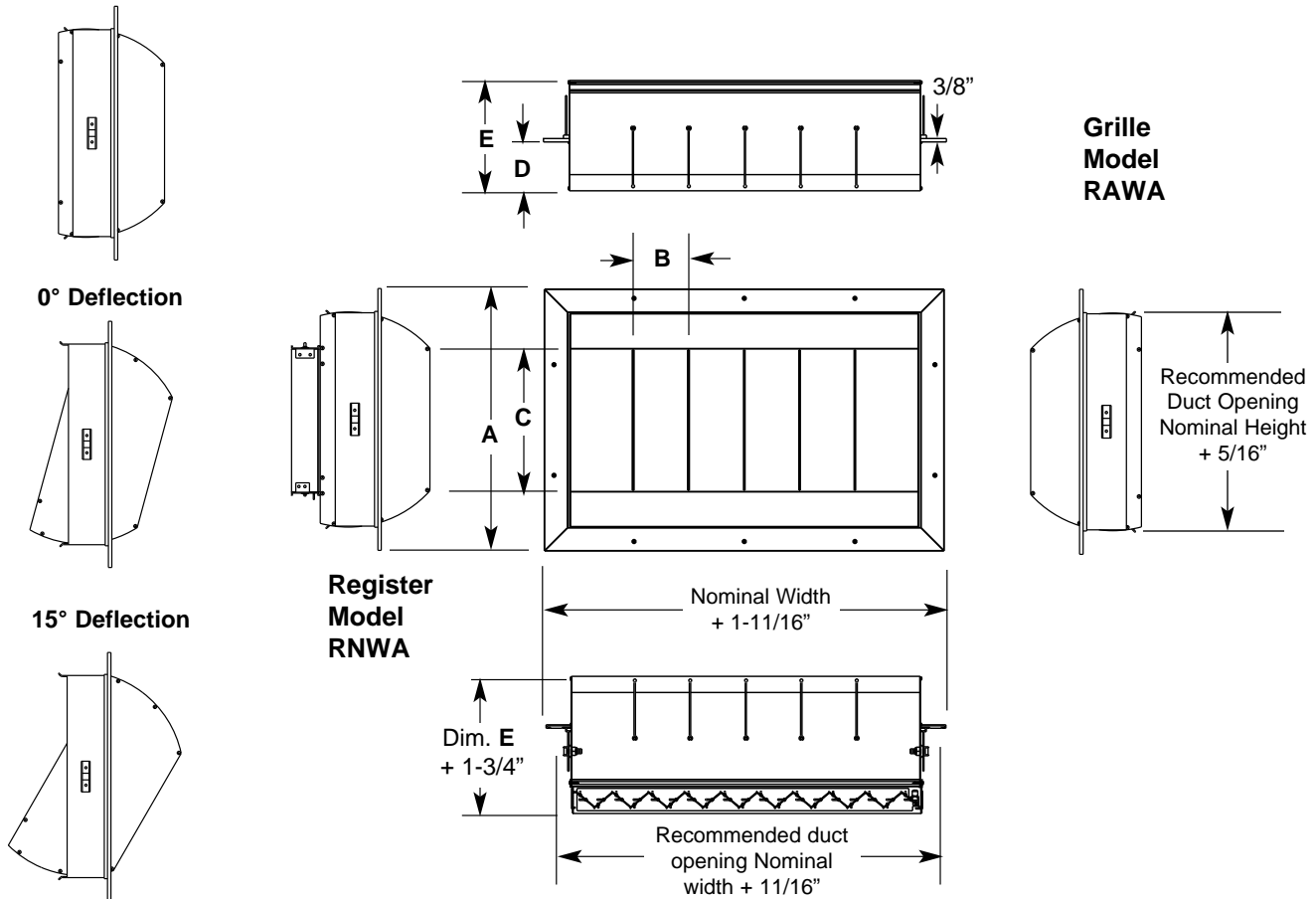

- Notes:**
1. Construction is 6063-T5 extruded aluminum.
 2. Felt gasket is used to seal the edge of the drum.
 3. Recommended duct opening is Nominal Width + 11/16" by Nominal Height + 5/16".
 4. Standard finish is mill finish. Other finishes are available upon request.
 5. Use of damper is recommended only when static pressure is .250 w.g. or lower.
 6. Drum is adjustable 30° up or down from the centerline.

Nominal Size	Height OD (A)	Blade Centers (B)	Core Height (C)	Forward Projection (D)	Grille Depth (E)
9" x 6"	8-3/16"	3"	3-3/8"	1-11/16"	4-3/8"
12" x 6"	8-3/16"	3"	3-3/8"	1-11/16"	4-3/8"
18" x 6"	8-3/16"	3"	3-3/8"	1-11/16"	4-3/8"
24" x 6"	8-3/16"	3"	3-3/8"	1-11/16"	4-3/8"
30" x 6"	8-3/16"	3"	3-3/8"	1-11/16"	4-3/8"
36" x 6"	8-3/16"	3"	3-3/8"	1-11/16"	4-3/8"
48" x 6"	8-3/16"	3"	3-3/8"	1-11/16"	4-3/8"
60" x 6"	8-3/16"	3"	3-3/8"	1-11/16"	4-3/8"
20" x 10"	11-15/16"	5"	5-7/8"	2-7/16"	6"
25" x 10"	11-15/16"	5"	5-7/8"	2-7/16"	6"
30" x 10"	11-15/16"	5"	5-7/8"	2-7/16"	6"
35" x 10"	11-15/16"	5"	5-7/8"	2-7/16"	6"
40" x 10"	11-15/16"	5"	5-7/8"	2-7/16"	6"
50" x 10"	11-15/16"	5"	5-7/8"	2-7/16"	6"
60" x 10"	11-15/16"	5"	5-7/8"	2-7/16"	6"
70" x 10"	11-15/16"	5"	5-7/8"	2-7/16"	6"

Nominal Size	Height OD (A)	Blade Centers (B)	Core Height (C)	Forward Projection (D)	Grille Depth (E)
20" x 12"	13-15/16"	5"	6-7/8"	3"	6"
30" x 12"	13-15/16"	5"	6-7/8"	3"	6"
40" x 12"	13-15/16"	5"	6-7/8"	3"	6"
50" x 12"	13-15/16"	5"	6-7/8"	3"	6"
60" x 12"	13-15/16"	5"	6-7/8"	3"	6"
70" x 12"	13-15/16"	5"	6-7/8"	3"	6"
15" x 15"	17"	5"	9-13/16"	3-13/16"	8-1/8"
20" x 15"	17"	5"	9-13/16"	3-13/16"	8-1/8"
25" x 15"	17"	5"	9-13/16"	3-13/16"	8-1/8"
30" x 15"	17"	5"	9-13/16"	3-13/16"	8-1/8"
40" x 15"	17"	5"	9-13/16"	3-13/16"	8-1/8"
50" x 15"	17"	5"	9-13/16"	3-13/16"	8-1/8"
60" x 15"	17"	5"	9-13/16"	3-13/16"	8-1/8"
70" x 15"	17"	5"	9-13/16"	3-13/16"	8-1/8"

SI (Metric) Dimensions
IP [English] on Reverse Side

CARNES COMPANY 448 S. Main St., P. O. Box 930040, Verona, WI 53593-0040 Phone: (608)845-6411 Fax: (608)845-6504 www.carnes.com

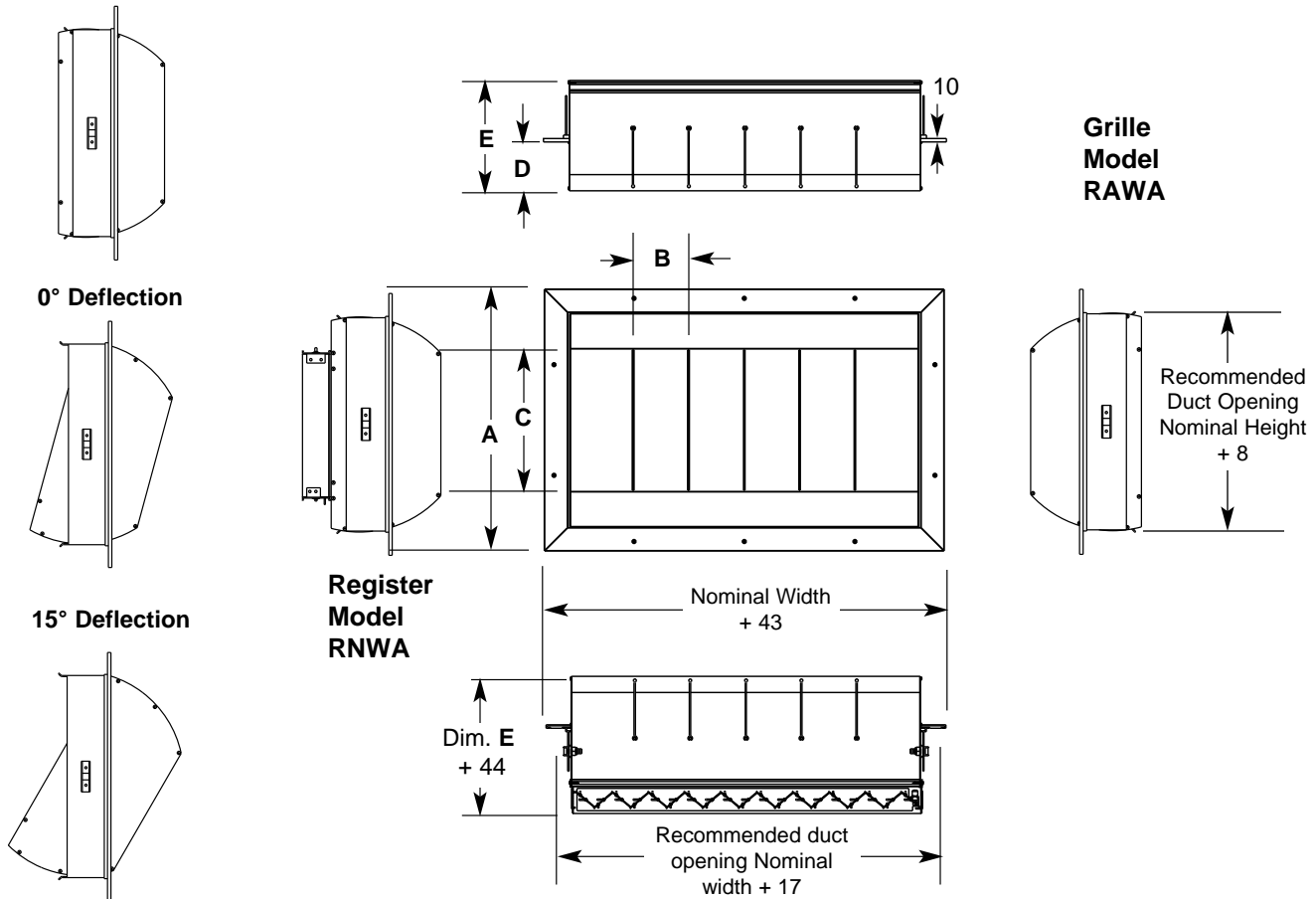

- Notes:**
1. Construction is 6063-T5 extruded aluminum.
 2. Felt gasket is used to seal the edge of the drum.
 3. Recommended duct opening is Nominal Width + 17 by Nominal Height + 8.
 4. Standard finish is mill finish. Other finishes are available upon request.
 5. Use of damper is recommended only when static pressure is .250 w.g. or lower.
 6. Drum is adjustable 30° up or down from the centerline.

Nominal Size	Height OD (A)	Blade Centers (B)	Core Height (C)	Forward Projection (D)	Grille Depth (E)
229 x 152	208	76	86	43	111
305 x 152	208	76	86	43	111
457 x 152	208	76	86	43	111
610 x 152	208	76	86	43	111
762 x 152	208	76	86	43	111
914 x 152	208	76	86	43	111
1219 x 152	208	76	86	43	111
1524 x 152	208	76	86	43	111
508 x 254	303	127	149	62	152
635 x 254	303	127	149	62	152
762 x 254	303	127	149	62	152
889 x 254	303	127	149	62	152
1016 x 254	303	127	149	62	152
1270 x 254	303	127	149	62	152
1524 x 254	303	127	149	62	152
1778 x 254	303	127	149	62	152

Nominal Size	Height OD (A)	Blade Centers (B)	Core Height (C)	Forward Projection (D)	Grille Depth (E)
508 x 305	354	127"	175	76	152
762 x 305	354	127	175	76	152
1016 x 305	354	127	175	76	152
1270 x 305	354	127	175	76	152
1524 x 305	354	127	175	76	152
1778 x 305	354	127	175	76	152
381 x 381	432	127	249	97	206
508 x 381	432	127	249	97	206
635 x 381	432	127	249	97	206
762 x 381	432	127	249	97	206
1016 x 381	432	127	249	97	206
1270 x 381	432	127	249	97	206
1524 x 381	432	127	249	97	206
1778 x 381	432	127	249	97	206