

Imperial [IP] Dimensions
Metric (SI) in Parentheses

CARNES COMPANY 448 S. Main St., P. O. Box 930040, Verona, WI 53593-0040 Phone: (608)845-6411 Fax: (608)845-6504 www.carnes.com

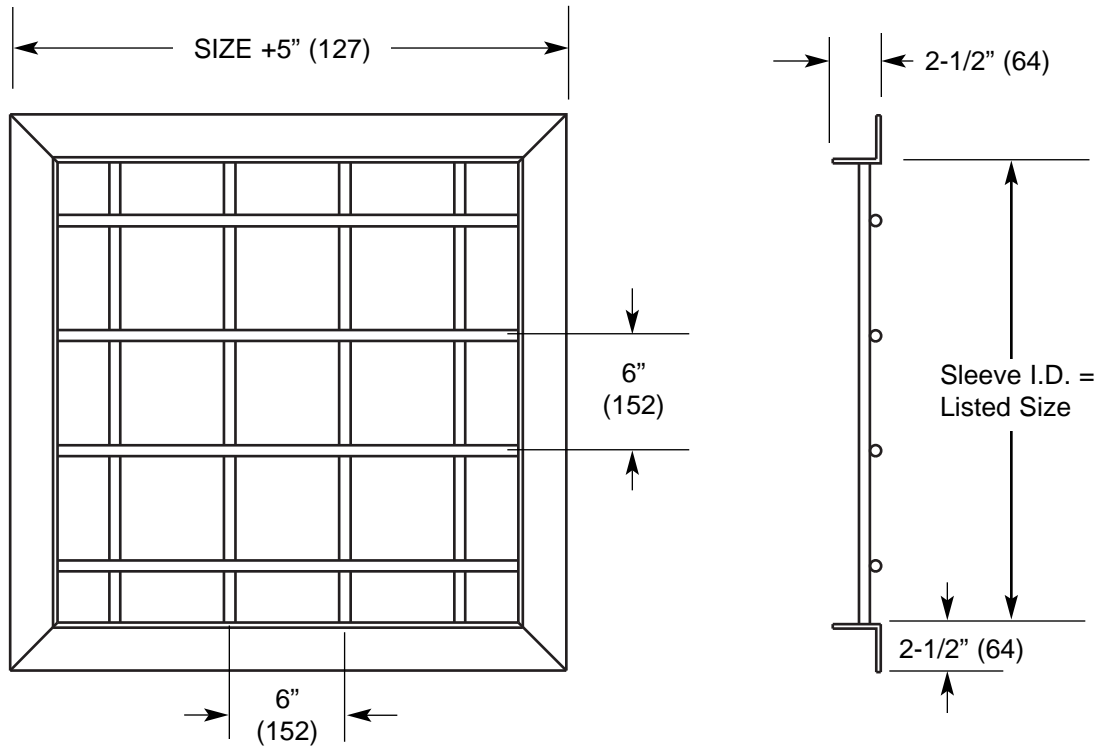

Construction Notes:

1. Frame is constructed of 2-1/2" x 2-1/2" x 1/4" (64 x 64 x 6) hot rolled steel.
2. Vertical Bars are constructed of 1/2" (13) diameter hot rolled steel.
3. Horizontal Bars are 1/2" (13) diameter hot rolled steel, placed on 6" (152) centers.
4. Bars are welded at all contact points, around the perimeter and to each other.
5. Finish is White Prime Coat.

Other Notes:

1. Metric dimensions are given in millimeters.
2. Unit can be field welded into place.
3. Recommended wall opening is nominal size plus 3/4" (19).