

Imperial [IP] Dimensions
Metric (SI) in Parentheses

CARNES COMPANY 448 S. Main St., P. O. Box 930040, Verona, WI 53593-0040 Phone: (608)845-6411 Fax: (608)845-6470 www.carnes.com

SECURITY PRODUCTS

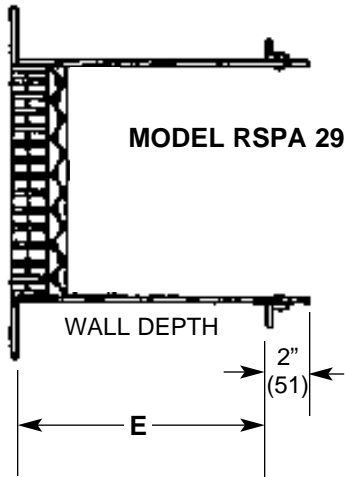
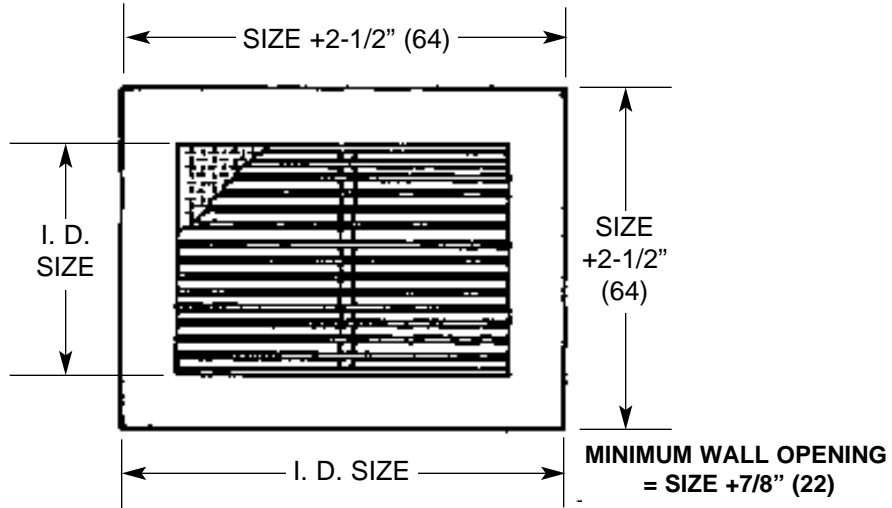

VOLUME DAMPER

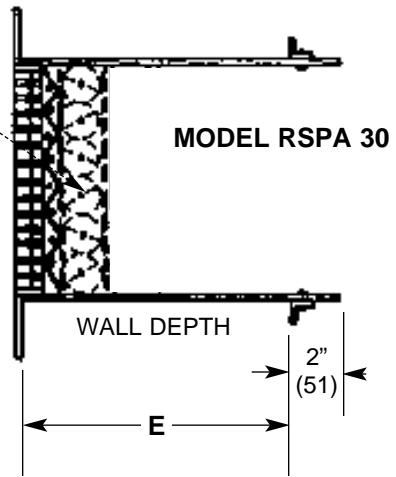

STANDARDS:

1. **Frame and Sleeves:** 14 gauge cold rolled steel construction.
2. **Louvered Bars:** .125 (3) x 1/2" (51) cold rolled steel welded at each end and each intermediate support.
3. **Wire Mesh:** 10 gauge .135 (3) x #2 mesh.
4. **Support Bars:** 1/4" (6) square. welded at 6" O.C. max.
5. **Mounting Screws:** Tamper-proof spanner head screws.
6. **Angles:** Furnished without mounting holes, for field welding to sleeve.
7. **Damper:** Balancing opposed blade damper, adjustable for volume of air front operated.
8. **Finish:** White Prime Coat.

OPTIONS:

1. Angles 1" x 1" x 1/8" (25 x 25 x 3) hot rolled steel with mounting holes for 1/5" (6) security bolts at 6" (152) O. C. max. Angles furnished loose for field mounting.
2. Louvered bars may be placed at 30° angle.