

Application:

0° Return R&G is used primarily as a return or exhaust grille or registers that matches the appearance of the supply outlet. It can be mounted on the wall or the ceiling.

Standard Features:

- Stainless steel (Type 304) construction is highly corrosion resistant.
- Teardrop blades are 3/4" deep, on 2/3" centers.
- Blades can be aligned horizontally or vertically.
- Deflection is fixed at 0° relative to the air stream.
- Mounts in most wall or ceiling styles.
- Minimum panel size is 4" x 4".
- Maximum panel size is 36" x 36". Panels can be joined for larger sizes (p. A311).
- Register RKR B uses RXTA opposed blade damper (p. A437).
- Standard finish is satin polish with one coat of clear lacquer.

Optional Features:

- Tamper-proof screws (p. A342).
- Concealed hangers (p. A343).
- Pull cord and lever damper operator (p. A343).
- Debris screen (p. A343).
- Unit can be set in T-bar panel (Opt. T), and certain sizes can be sheared (Opt. S) to fit T-bar grids (p. A341).

Quick Select Chart

This shows grilles with:

- A maximum NC of 35.
- A minimum duct velocity of 300 FPM.

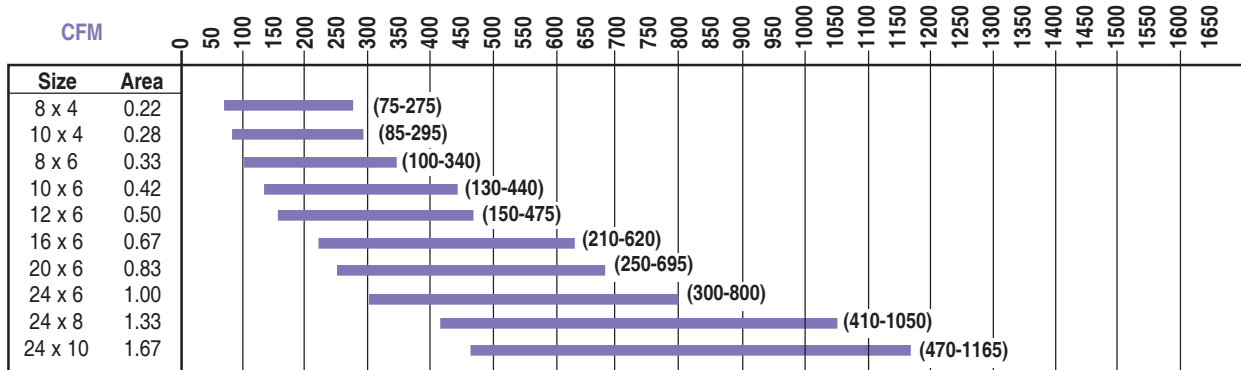

Model Numbering System

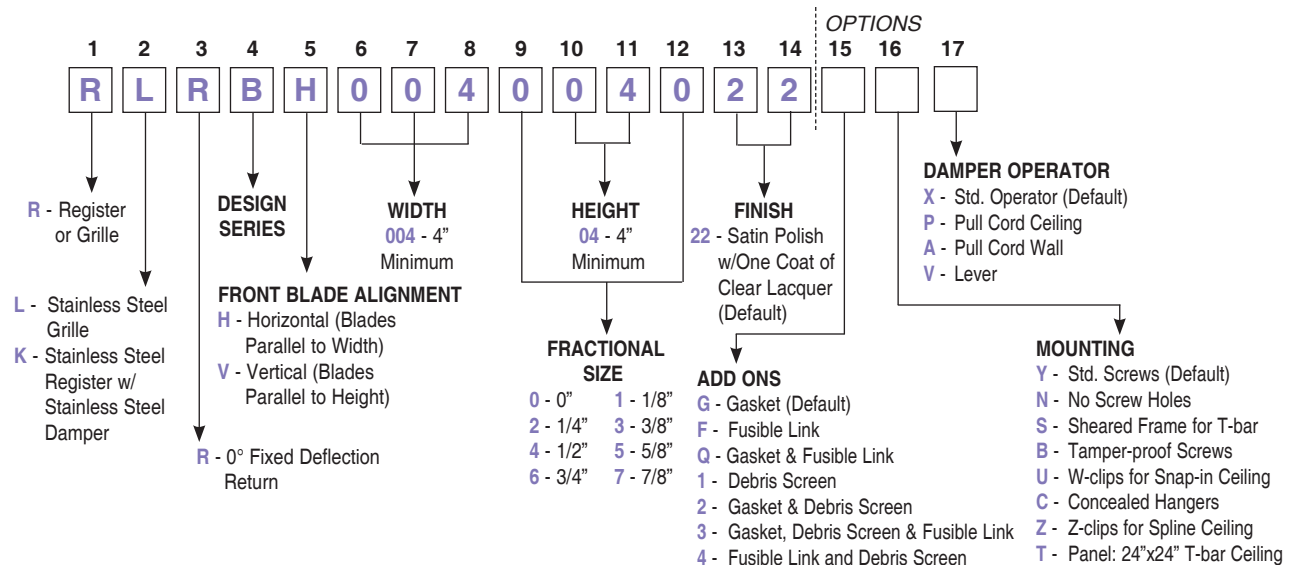

- Steel 0° (RSRB, RTRB) • Aluminum 0° (RARM, RNRM) • Stainless Steel 0° (RLRB, RKRB)
- Steel 45° (RSAB, RTAB) • Aluminum 45° (RAAM, RNAM) • Stainless Steel 45° (RLAB, RKAB)

Correction Factors for Grille Performance

Total Pressure (Pt)

- For a 0° deflection grille, use the data unchanged from the table.
- For a 45° deflection grille, multiply the table data by 1.8.

Sound Level (NC)

- For a 0° deflection grille, use the table data unchanged.
- For a 45° deflection grille, add 5db to the table data.

Correction Factors for Register Performance

Total Pressure (Pt)

- For a 0° deflection register with a wide open damper, multiply the table data by 1.2.
- For a 45° deflection register with a wide open damper, multiply the table data by 2.0.

Sound Level (NC)

- For a 0° deflection register with a wide open damper, add 2db to the table data.
- For a 45° deflection register with a wide open damper, add 7db to the table data.

Duct Velocity (fpm)		200	400	600	800	1000
Total Pressure (w. g.)		0.020	0.050	0.090	0.140	0.200
4x4	Flow (CFM)	22	44	66	88	110
(.11 ft ²)	Sound (NC)	—	—	—	—	—
6x6	Flow (CFM)	50	100	150	200	250
(.25 ft ²)	Sound (NC)	—	—	—	—	21
8x6	Flow (CFM)	65	130	200	270	340
(.33 ft ²)	Sound (NC)	—	—	—	—	24
10x6	Flow (CFM)	80	160	240	320	400
(.42 ft ²)	Sound (NC)	—	—	—	20	26
12x6	Flow (CFM)	90	180	260	350	440
(.50 ft ²)	Sound (NC)	—	—	—	21	27
14x6	Flow (CFM)	110	220	330	440	550
(.58 ft ²)	Sound (NC)	—	—	—	23	29
12x8	Flow (CFM)	140	280	400	550	690
(.67 ft ²)	Sound (NC)	—	—	—	25	32
12x10	Flow (CFM)	160	320	480	640	800
(.83 ft ²)	Sound (NC)	—	—	—	26	33
12x12	Flow (CFM)	200	400	600	800	1000
(1.00 ft ²)	Sound (NC)	—	—	21	29	35
14x14	Flow (CFM)	270	540	820	1090	1360
(1.36 ft ²)	Sound (NC)	—	—	23	31	37
18x12	Flow (CFM)	310	620	930	1240	1550
(1.50 ft ²)	Sound (NC)	—	—	24	32	39
16x16	Flow (CFM)	360	710	1070	1420	1780
(1.77 ft ²)	Sound (NC)	—	—	26	34	41

Performance Data Notes:

- Sound values are given in NC, are based on a room absorption of 10db re 10⁻¹² watts.
- Pressure values are given in inches of water.
- Flow values are given in cubic feet per minute.
- Actual performance in the field may vary.

- Steel 0° (RSRB, RTRB) • Aluminum 0° (RARM, RNRM) • Stainless Steel 0° (RLRB, RKRB)
- Steel 45° (RSAB, RTAB) • Aluminum 45° (RAAM, RNAM) • Stainless Steel 45° (RLAB, RKAB)

Duct Velocity (fpm)		200	400	600	800	1000
Total Pressure (w. g.)		0.020	0.050	0.090	0.140	0.200
18x16, 24x12 (2.00 ft ²)	Flow (CFM)	400	800	1200	1600	2000
	Sound (NC)	—	—	27	35	42
18x18 (2.25 ft ²)	Flow (CFM)	450	900	1200	1800	2200
	Sound (NC)	—	—	28	36	43
36x12, 24x18 (3.00 ft ²)	Flow (CFM)	600	1200	1800	2400	3000
	Sound (NC)	—	—	30	39	45
24x24 (4.00 ft ²)	Flow (CFM)	800	1600	2400	3200	4000
	Sound (NC)	—	21	33	42	48
36x18 (4.50 ft ²)	Flow (CFM)	900	1800	2700	3600	4500
	Sound (NC)	—	22	34	43	49
30x24, 36x20 (5.00 ft ²)	Flow (CFM)	1000	2000	3000	4000	5000
	Sound (NC)	—	23	35	44	50
36x24, 48x18 (6.00 ft ²)	Flow (CFM)	1200	2400	3600	4800	6000
	Sound (NC)	—	24	36	45	52
36x36 (9.00 ft ²)	Flow (CFM)	1800	3600	5400	7200	9000
	Sound (NC)	—	29	41	49	56
40x36 (10.00 ft ²)	Flow (CFM)	2000	4000	6000	8000	10000
	Sound (NC)	—	30	42	50	57
44x36 (11.00 ft ²)	Flow (CFM)	2200	4400	6600	8800	11000
	Sound (NC)	—	31	43	52	59
48x36 (12.00 ft ²)	Flow (CFM)	2400	4800	7200	9600	12000
	Sound (NC)	—	33	45	54	61

Performance Data Notes:

- Sound values are given in NC, are based on a room absorption of 10db re 10⁻¹² watts.
- Pressure values are given in inches of water.
- Flow values are given in cubic feet per minute.
- Actual performance in the field may vary.

Multi-Panel Construction for the following Registers & Grilles

	Steel	Stainless Steel	Aluminum
Single Deflection	RSSB, RTSB	RLSB, RKSB	RASM, RNSM
Double Deflection	RSDB, RTDB	RLDB, RKDB	RADM, RNDM
0° Fixed Return	RSRB, RTRB	RLRB, RKRB	RARM, RNRM
45° Fixed Return	RSAB, RTAB	RLAB, RKAB	RAAM, RNAM

In-line Construction

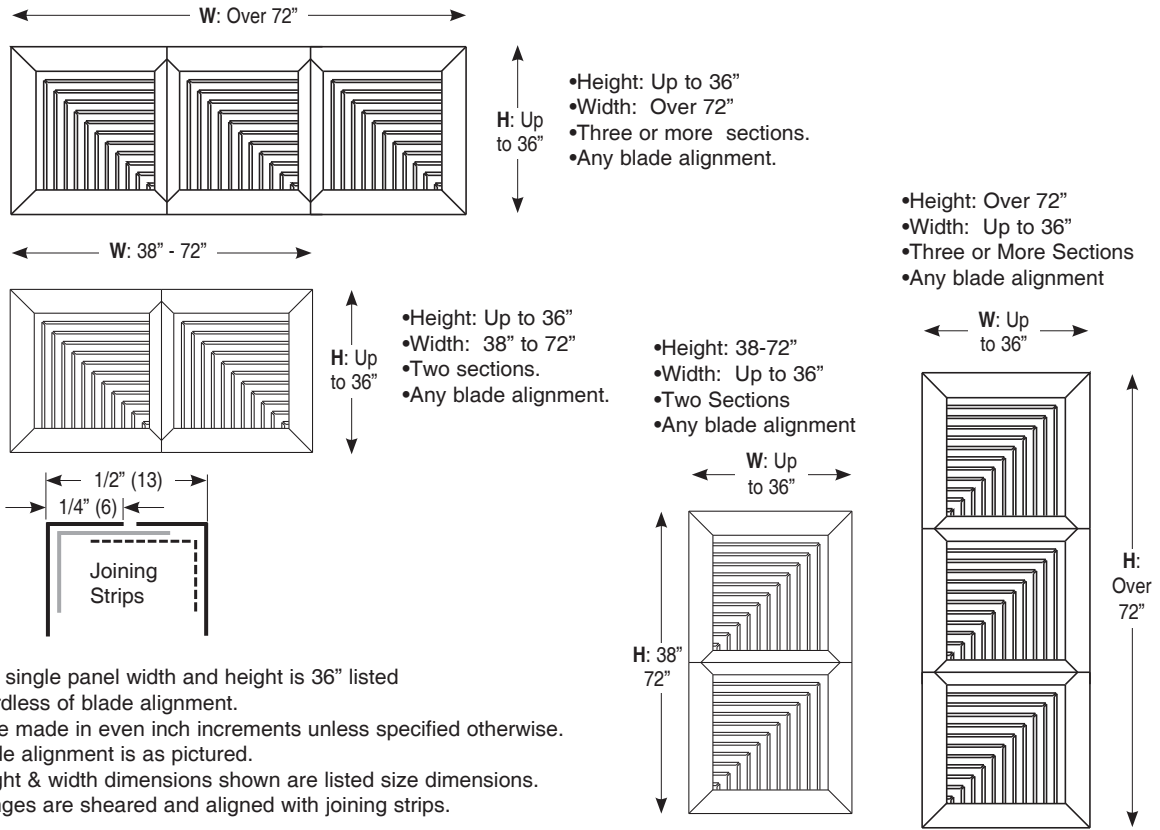

Notes:

1. Maximum single panel width and height is 36" listed size regardless of blade alignment.
2. Panels are made in even inch increments unless specified otherwise.
3. Front blade alignment is as pictured.
4. Grille height & width dimensions shown are listed size dimensions.
5. Panel flanges are sheared and aligned with joining strips.

Ganged Construction

Notes:

1. Maximum single panel width is 36" listed size.
2. Maximum single panel height is 36" listed size.
3. Panels will be made in even inch increments unless specified otherwise.
4. Front blade alignment is always parallel to center support.
5. Either the vertical or horizontal joint can be sheared down, but not both.
6. The center support can be aligned vertically or horizontally, depending on blade alignment desired. It is shown here mounted horizontally.
7. Grille height and width dimensions shown are listed size dimensions.
8. Metric dimensions are shown in millimeters.

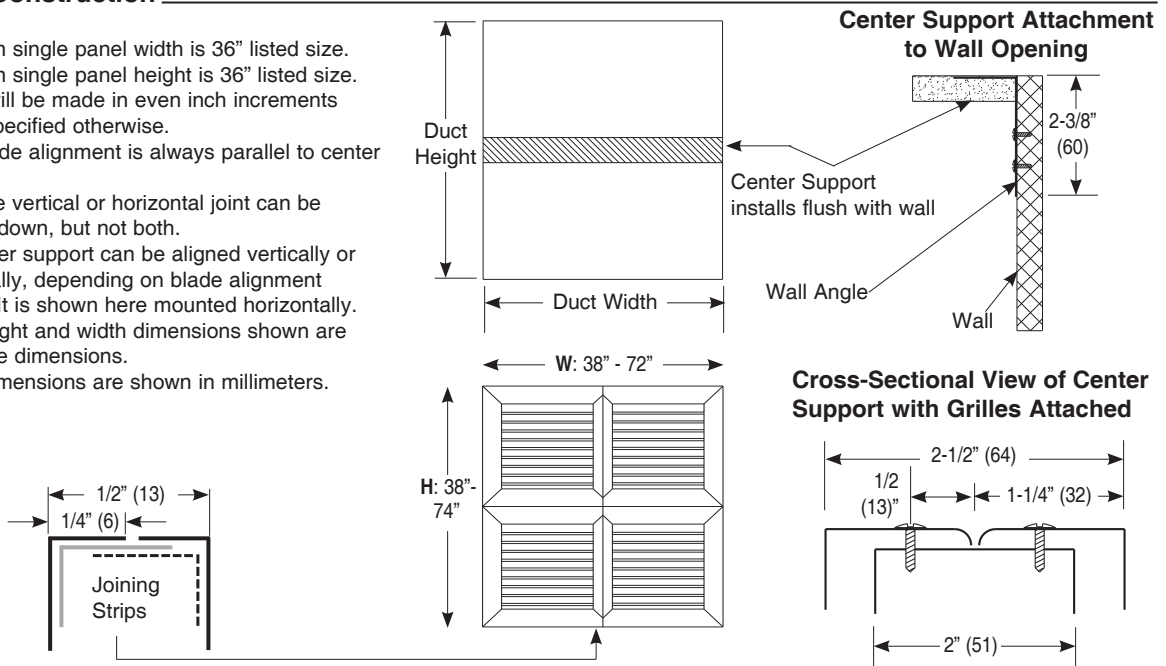

Multi-Panel Construction for the following Registers & Grilles

Steel
 Louvered Return RSLA, RTLA
 Perforated Return RSFA, RTFA

In-Line Construction

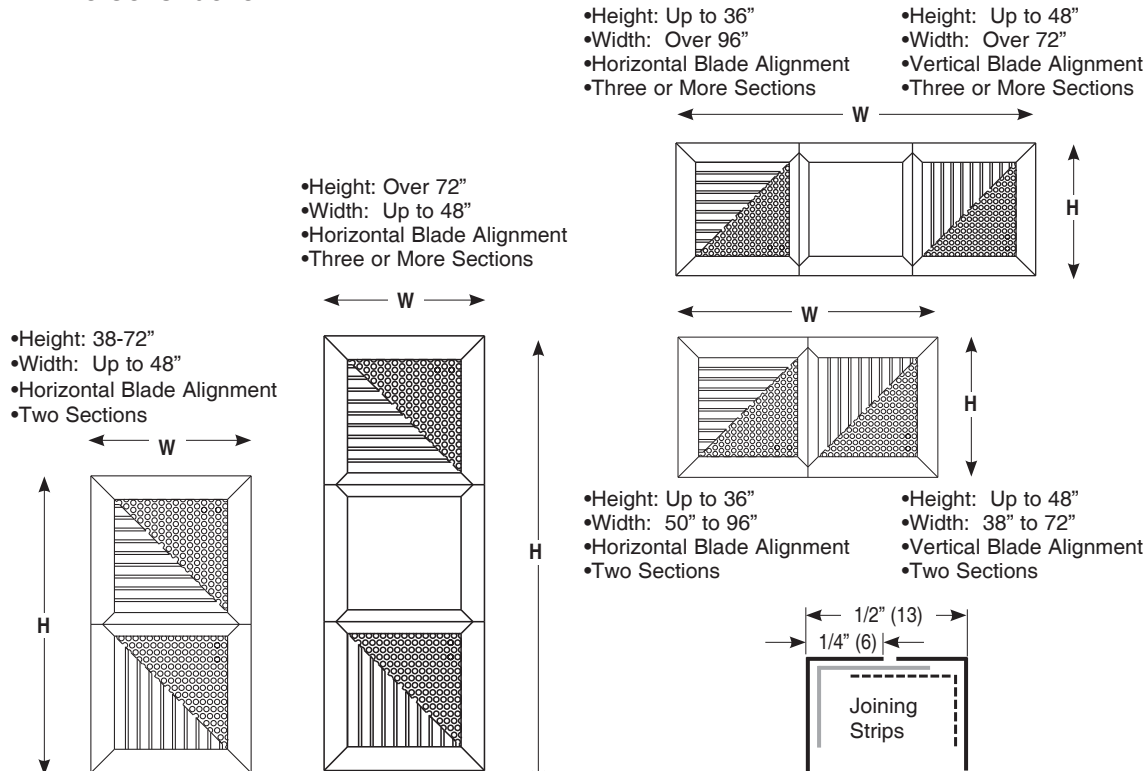

Notes:

1. Panels will be made in even inch increments unless specified otherwise.
2. Dimensions shown are listed size dimensions.
3. Max. blade length on louvered face models is nominal 48".
4. Panels are sheared and aligned with joining strips.

Ganged Construction

Notes:

1. Either the vertical or horizontal joint can be sheared down, but not both.
2. Maximum single panel width is 48" listed size.
3. Maximum blade length on louvered face models is listed size 48".
4. Maximum single panel height is 36" listed size.
5. Panels are made in even inch increments unless specified otherwise.
6. Blade alignment is always parallel to center support.
7. The center support can be aligned vertically or horizontally, depending on the blade alignment desired. It is shown here mounted horizontally.
8. Grille dimensions shown are listed size dimensions.

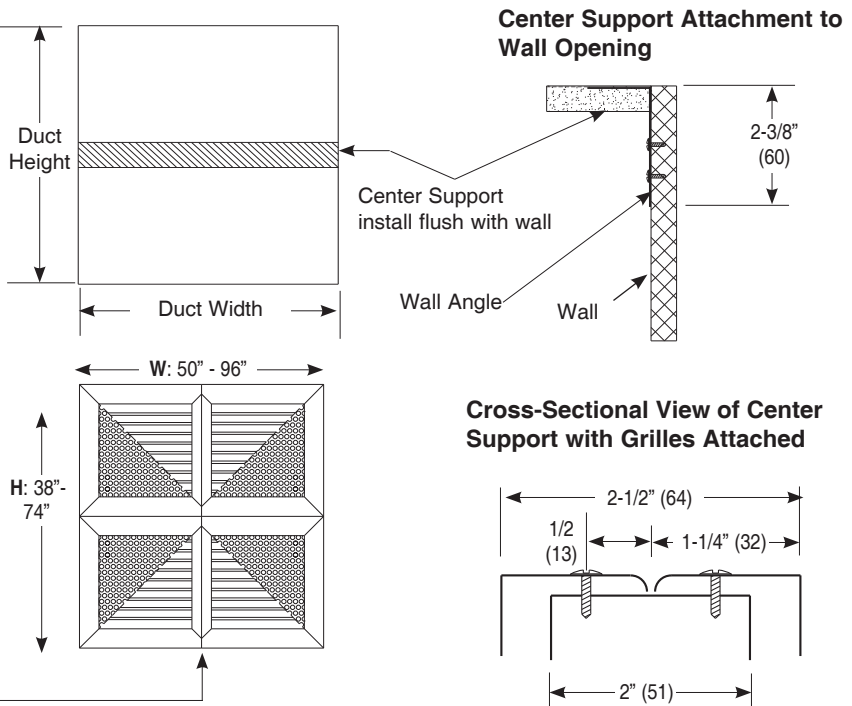
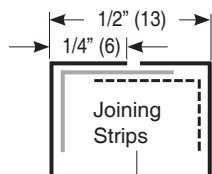

Multi-Panel In-Line Construction

Notes:

1. Maximum single panel width and height is 48" nominal size, regardless of blade alignment.
2. Panels are made in even inch increments unless specified otherwise.
3. Front blade alignment is as pictured.
4. Grille dimensions shown are nominal dimensions.
5. Panel flanges are sheared and aligned with joining strips.

- Height: 50-96"
- Width: Up to 48"
- Two Sections
- Any Blade Alignment

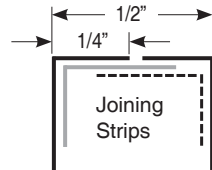
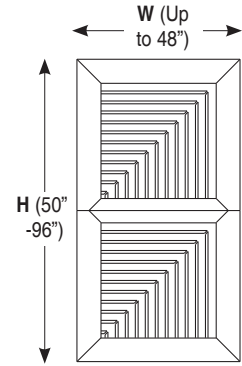

- Height: Over 96"
- Width: Up to 48"
- Three or more Sections
- Any Blade Alignment

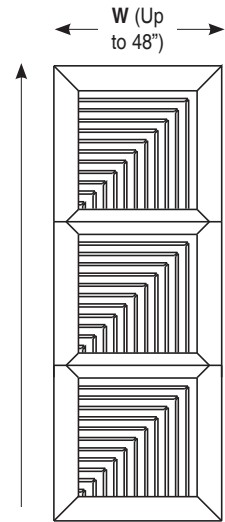

- Height: Up to 48"
- Width: 50" - 96"
- Two Sections
- Any Blade Alignment

- Height: Up to 48"
- Width: Over 96"
- Three or more Sections
- Any Blade Alignment

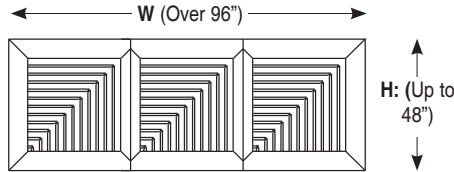
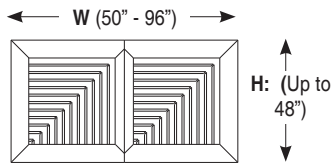

Multi-Panel Ganged Construction

Notes:

1. Maximum single panel width and height are 48" nominal size.
2. Panels are made in even inch increments unless specified otherwise.
3. Front blade alignment is always parallel to center support.
4. Either the vertical or horizontal joint can be sheared down, but not both.
5. The center support can be aligned vertically or horizontally, depending on blade alignment desired.
6. Grille dimensions shown are nominal dimensions.

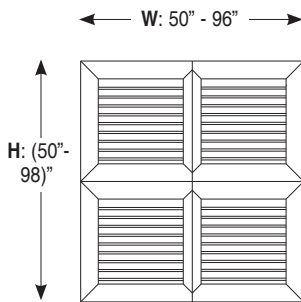

Cross-Sectional View of Center Support

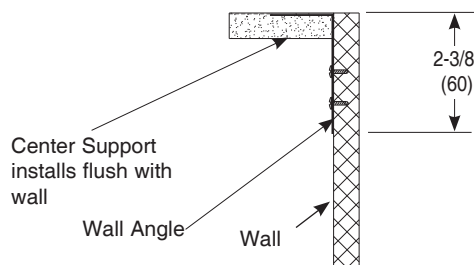
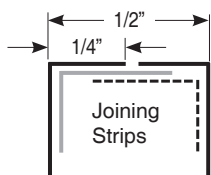
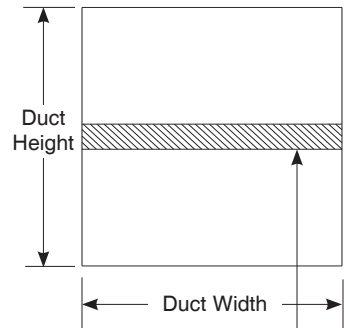
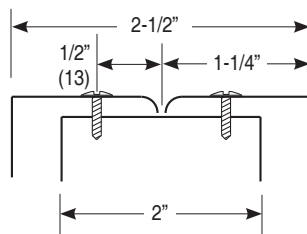

Center Support Mounted flush with wall (Shown aligned horizontally).

Sq. & Rect. Registers & Grilles

All Sections of Butted Grilles or Registers will be made in Listed Sizes as Standard.

STANDARD REGISTERS AND GRILLES

Applies to all models except louvered return air registers and grilles and door partition grilles.
Registers and grilles over 36" x 36" butting two or more grilles together.

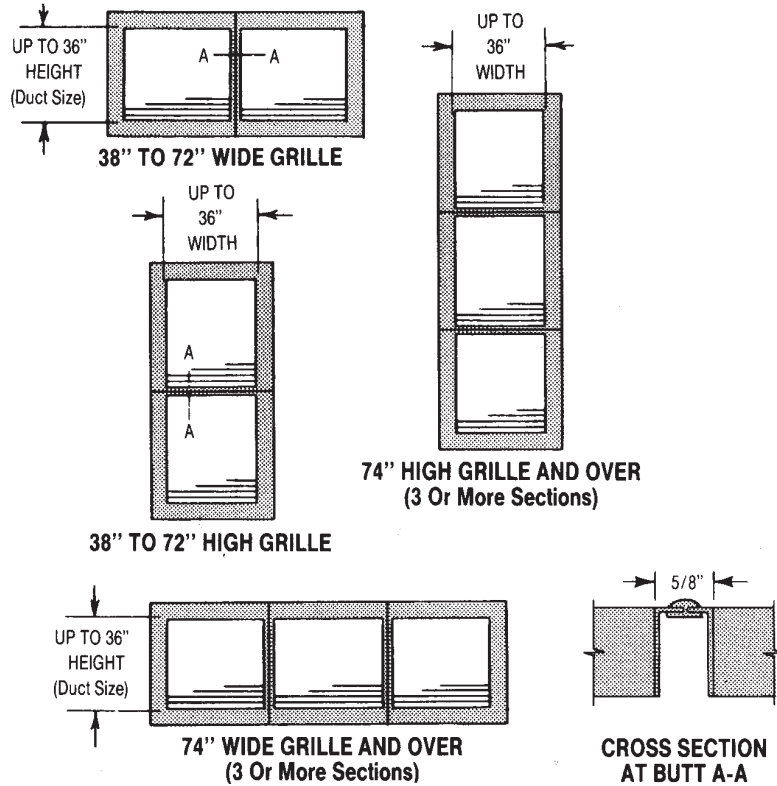

GRILLES AND REGISTERS HAVING FOUR SECTIONS AND OVER

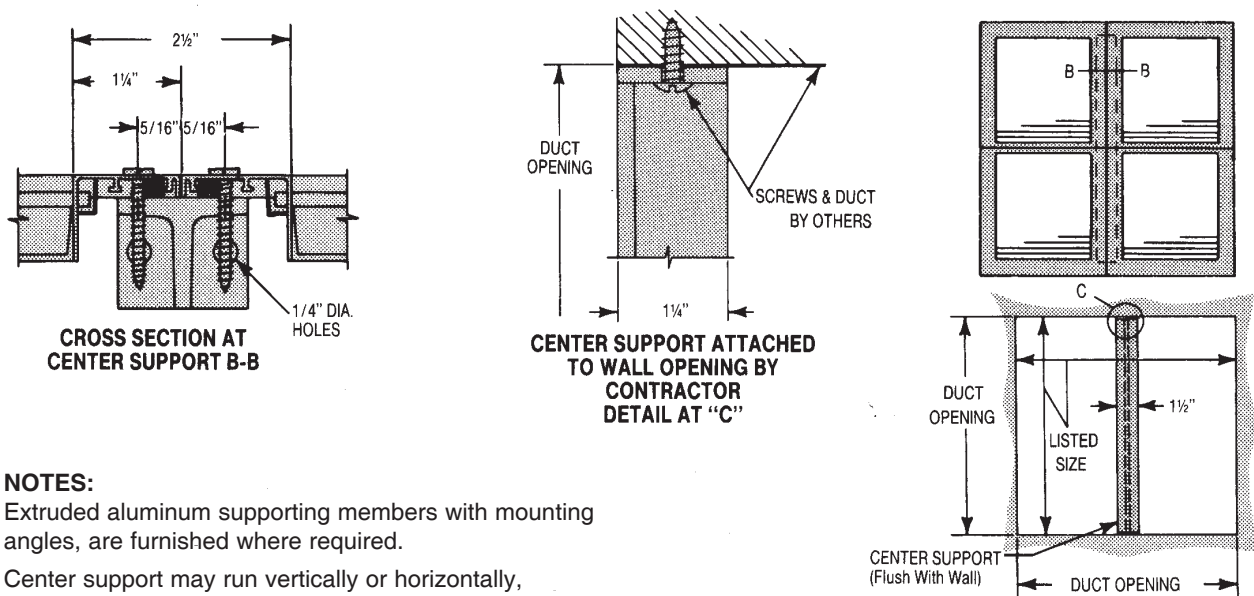

NOTES:

Extruded aluminum supporting members with mounting angles, are furnished where required.

Center support may run vertically or horizontally, depending upon combination of grilles used.

Combination of panels will be furnished to fit duct opening with satisfactory clearance.

Screw Hole Location for the following Registers & Grilles

	Steel	Aluminum	Stainless Steel
Single Deflection	RSSB, RTSB	RASM, RNSM	RLSB, RKSB
Double Deflection	RSDB, RTDB	RADM, RNDM	RLDB, RKDB
0° Fixed Return	RSRB, RTRB	RARM, RNRM	RLRB, RKRB
45° Fixed Return	RSAB, RTAB	RAAM, RNAM	RLAB, RKAB
Louvered Return	RSLA, RTLA	-----	-----
Perforated Return	RSFA, RTFA	RAFM, RNFM	-----

Notes:

- Screw holes on the face are standard on Registers and Grilles.
- Steel R&G can be ordered without screw holes, for use with concealed hangers (Opt. N).
- The screw holes is 5/32" in diameter.
- Each Register or Grille is provided with the appropriate number of screws as standard.
- The standard screw is #8 x 1-1/4" pan head screw, with a flat blade head.
- Tamper-proof screws are available as an option (Opt. B).

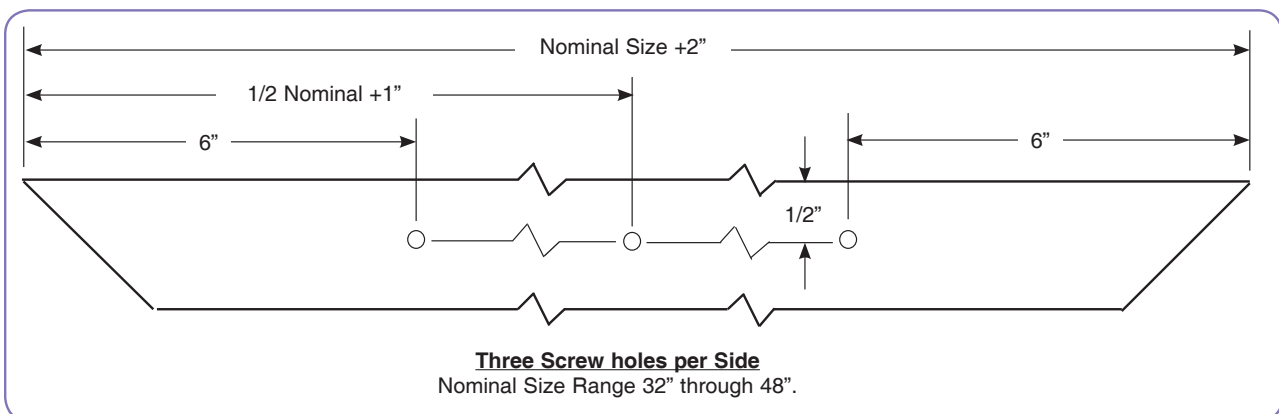
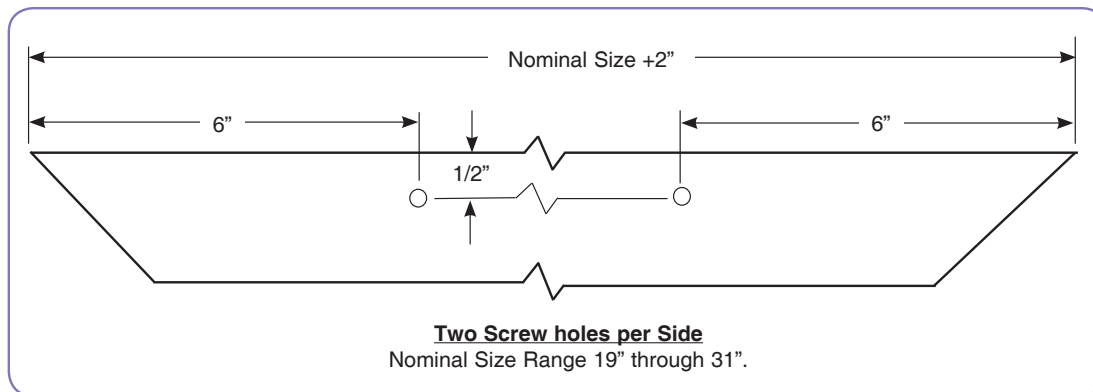
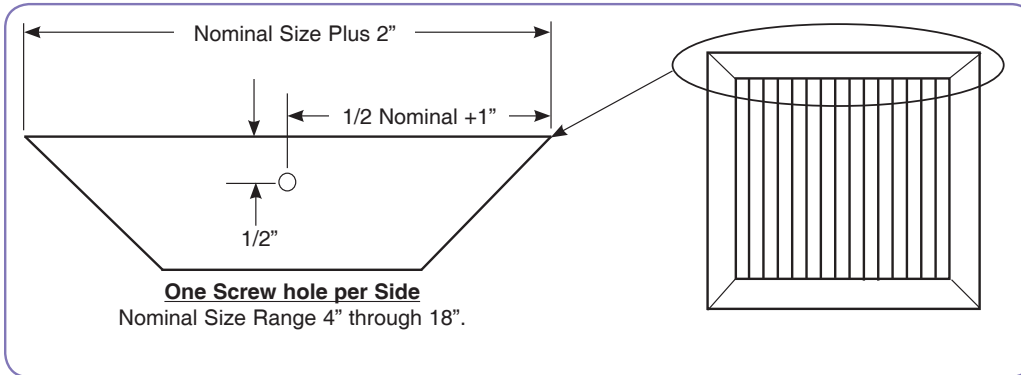

Sq. & Rect. Registers & Grilles