

Application

Security Transfer Grilles are used in minimum security areas to pressure equalization between two adjacent spaces. Because the faces are welded to each end of the sleeve this must be installed at the time the wall is being constructed.

Standard Features

- Faces and sleeve are 12 gauge hot-rolled steel.
- Hole pattern in face plates is 1/2" square holes on 11/16" centers.
- Standard finish is electrocoat acrylic baked enamel.
- Standard color is #11 bright white.
- Stainless steel construction available upon request. Please contact factory for pricing and availability.

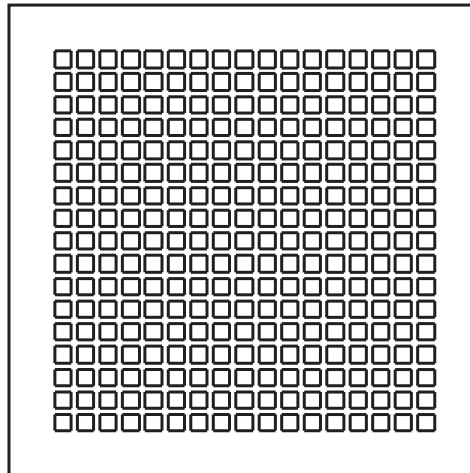
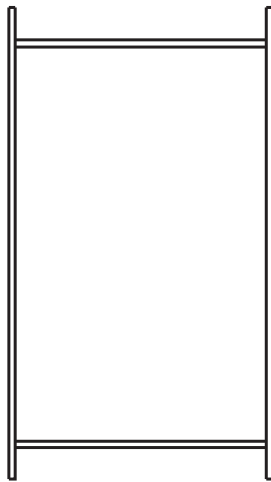

Model Numbering System

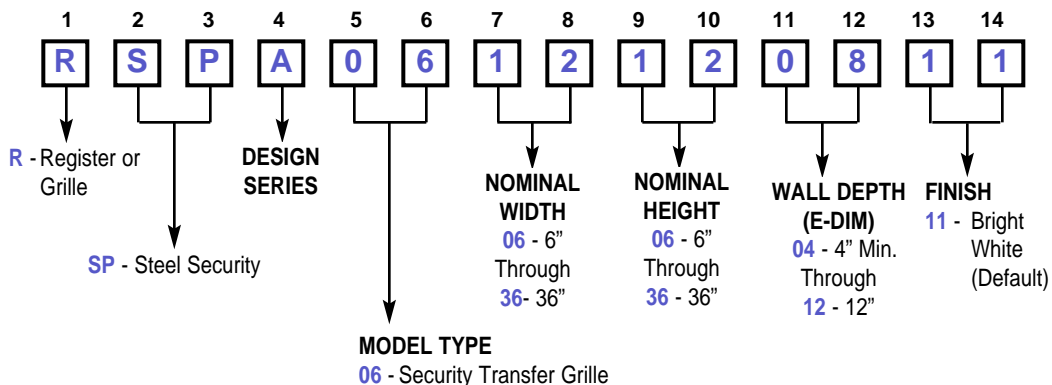

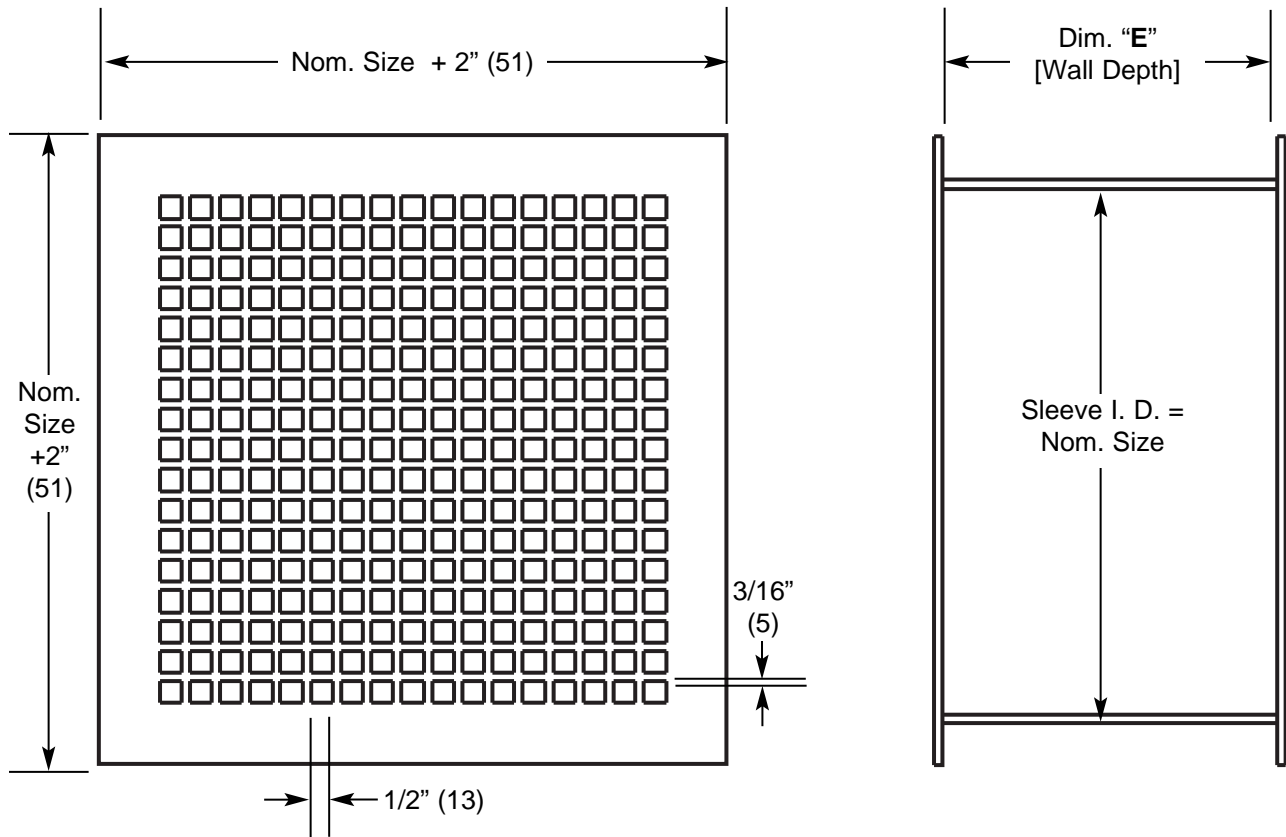

Overall Notes:

- Faces are 12 gauge hot rolled steel, with 1/2" (13) square holes on 3/16" (5) frets.
- Sleeve is constructed of 12 gauge hot rolled steel.
- Metric dimensions are given in millimeters.
- Standard finish is electrocoat acrylic baked enamel.
- Standard color is #11 bright white.
- This must be installed prior to the concrete wall being cast.
- On large sizes, face may warp slightly, up to 1/2" over one foot.
- Size 12" x 12" (305 x 305) with an 8" (203) wall depth, is shown above.

Option “H” - Mounting Angles for Field Bolting onto Wall R&G

Application

The RSPA 51 group is used in security applications where there is a concern that the occupant may attempt suicide. The 3/16” perforated hole pattern is designed to deter passage of any string through the face and back. This hole pattern also prevents any chance to hide contraband. This is not a substitute for proper security practices. Because of the perforated hole pattern, the opposed blade damper needs to be accessed from the back side.

Features

- Mounting angles are provided with holes punched on 6” centers.
- There are a minimum of 2 holes per mounting angle.
- The bolts provided are #1/4-20 x 1” snake-eyes head.
- The nuts provided are 1/4-20 self-locking hex nuts.

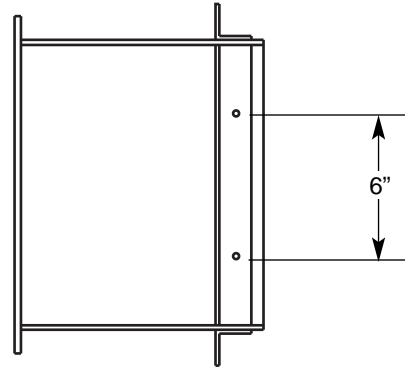

Barrier Bar Options

Option B - 1/2” round bar on 6” centers.

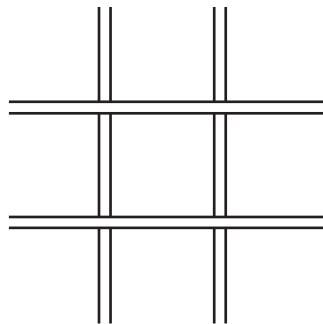

Option C - 3/4” round bar on 6” centers.

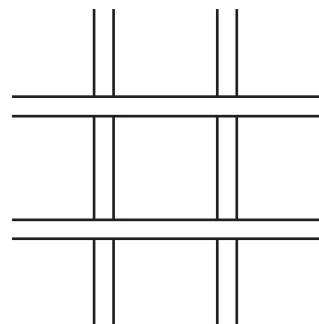

Option D - 3/4” round bar vertical on 6” centers through horizontal bars (3/8” x 2-1/2”) on 12” centers. All intersections are welded.

