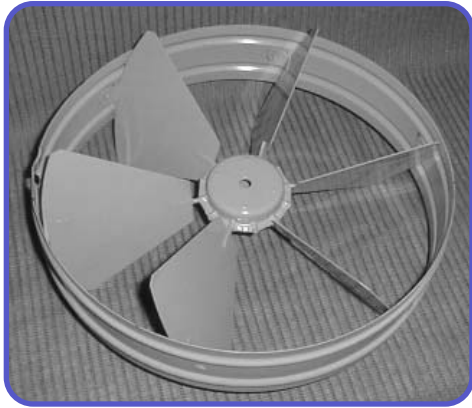

## OVERVIEW | Radial Deflector (KXNA)

CARNES®

**Application**

Use for fine balancing of flow and as an equalizing grid with Round Diffuser Models SSEA, SSAA and SSMA.

**Features**

- Blades are individually adjustable for fine control.
- Construction is heavy gauge steel.
- Standard finish is electrocoat acrylic enamel. Other finishes are available on request.
- Standard color is #04 gray. Other colors are available on request.

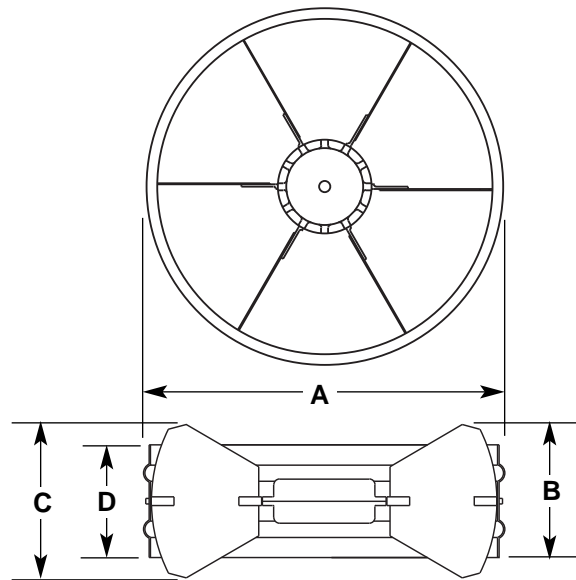
**Dimensional Data**

Dim.	Description	5	6	8	10	12	14	16	18	20	24	28	32	36
A	Unit Outside Diameter	4-11/16	5-11/16	7-5/8	9-11/16	11-3/4	13-11/16	15-13/16	17-3/4	19-13/16	23-11/16	27-11/16	31-5/8	35-5/8
B	Max. Unit Height	1-11/16	2-1/16	3-3/16	4-3/16	5-3/16	3-5/16	3-13/16	4-5/16	4-13/16	5-15/16	7-5/16	7-13/16	8-15/16
C	Max. Overall Height	1-11/16	2-1/16	3-1/2	4-1/2	5-1/2	3-3/8	3-7/8	4-3/8	4-15/16	5-15/16	6-15/16	8	9
D	Collar Height	1-3/16	1-3/16	2-7/16	2-7/16	2-7/16	2-7/16	2-7/16	2-7/16	2-7/16	2-7/16	2-7/16	2-7/16	2-7/16
	Blade Quantity	8	8	6	6	6	12	12	12	12	12	12	12	12

**Model Numbering System**