

Duct Mounted Smoke Detector - Typical Installation

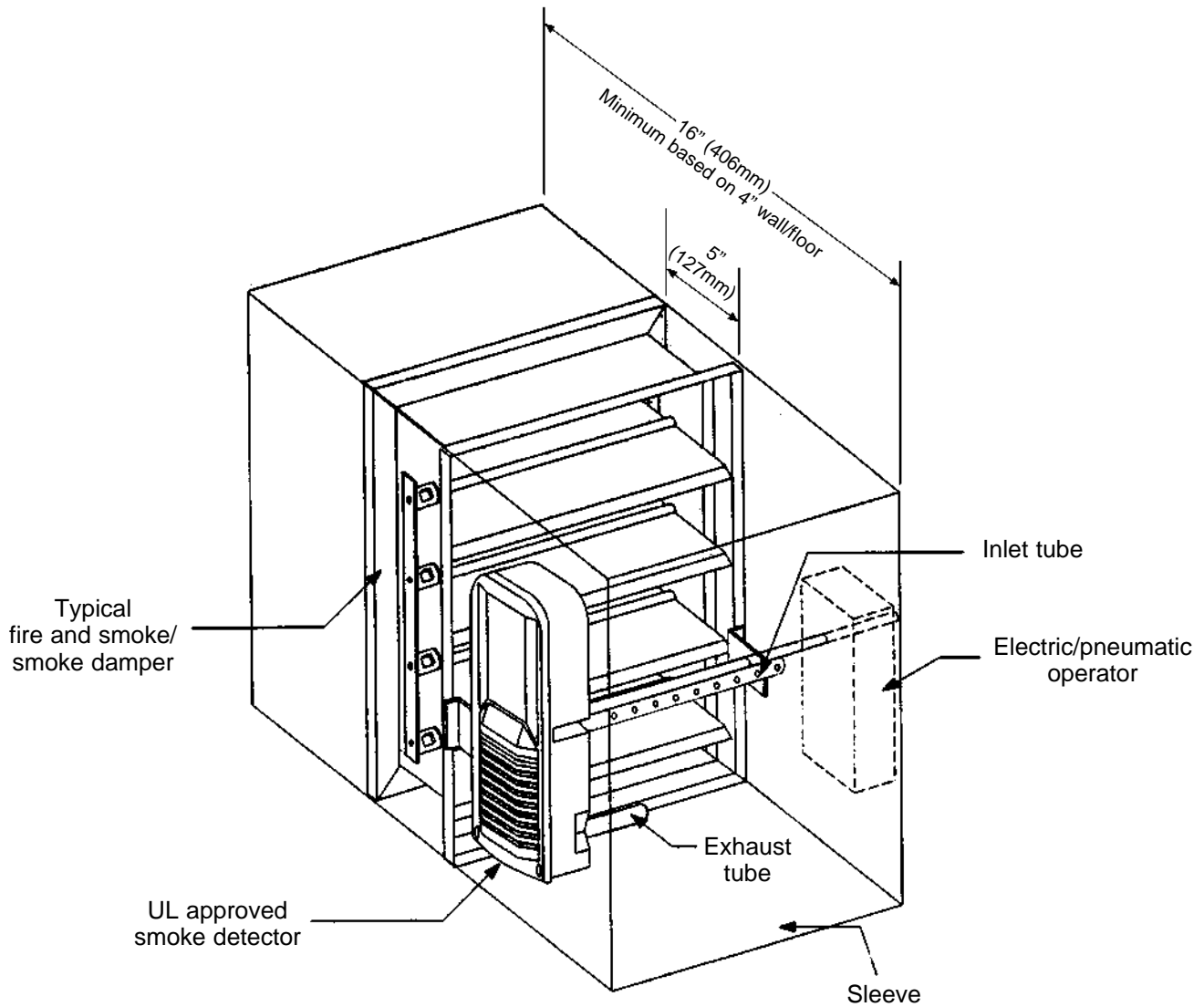

NOTE: Minimum Size 12 x 10

Manufacturer's Recommendations

All moving parts of the damper must be inspected and cycled at intervals not greater than every 12 months or in accordance with the latest of NFPA 90A, 92A, local codes and the actuator manufacturer. In addition, fuse links shall be removed and inspected for corrosion. Dry lubricants are recommended.

Specifications are correct at time of printing. However, as part of our 'continuous improvement program', we reserve the right to make further improvements without notice.