

LIGHT COMMERCIAL & PREMIER HOME OR CONDOMINIUM STEAM HUMIDIFIERS



Status display visible with door closed and locked.



Hinged door provides full access for service.



Steam cylinder easily removed for replacement.

Two Sizes Available

Size 005 satisfies areas up through 1400 square feet. Size 010 will humidify areas up through 2800 square feet under normal conditions. If multiple furnaces are used a separate humidifier should be used for each.

Pure, Clean Steam vs. Evaporative

Because of their purity steam humidifiers have been used in critical applications such as hospital operating rooms, computer rooms and electronic manufacturing for years. Evaporative humidifiers do not boil water and provide a place for organisms to accumulate and grow.

Sealed Cylinder vs. Pad

The sealed disposable plastic cylinder captures the hard mineral deposits that are left behind by boiling water. Only pure steam vapor leaves the steam cylinder and the mineral residue is completely harmless. Since the water is sterilized each time the cylinder operates there is no possibility of slimy residue that is objectionable to handle.

Maintenance

Typical maintenance consists of changing the plastic steam cylinder after 500 to 2000 hours of operation. A "Service" light on the humidifier conveniently indicates the need for service. Changing the plastic cylinder usually takes ten minutes. Typical evaporative humidifiers do not have any indication of their need for service and no warning is given until humidity drops below the desired levels.

Modulating Control vs. On-Off

A highly desirable feature of Carnes humidifiers is the ability to modulate the output to meet humidity requirements. This option allows the humidifier to automatically adjust its output to match the amount of humidity required. Evaporative humidifiers are either on or off, allowing humidity levels to fluctuate which can provide spikes of low and high humidity.

CARNES STEAM HUMIDIFIERS use a microprocessor, digital display and LED's to provide superior operating and diagnostic functions to simplify troubleshooting and reduce maintenance costs.

OPERATION

Upon a signal from a humidistat the circuit board opens a **fill solenoid valve**, allowing water to flow across a 1" **air gap** into a **standpipe**. The air gap prevents back flow to the water supply and prevents the cylinder from becoming a pressure vessel.

The circuit board also closes a **power contactor** allowing current to flow to **vertical electrodes** sealed inside the cylinder. Current flows between the electrodes using minerals in the water as a conductor. The water is heated to boiling and converted to steam, which leaves the cylinder through the flexible **steam hose**.

The circuit board automatically opens the fill solenoid valve when more water is required to maintain the desired output rate. The operation of the **drain solenoid valve** is also controlled by the circuit board, to provide stable operation and long cylinder life.

As mineral deposits build up in the cylinder the water level will slowly rise to cover more electrode surface to maintain the desired steam output rate. When mineral deposits have covered all available electrode surface areas, current flow will be reduced so that the desired steam output cannot be reached. The service light will signal the need for maintenance.

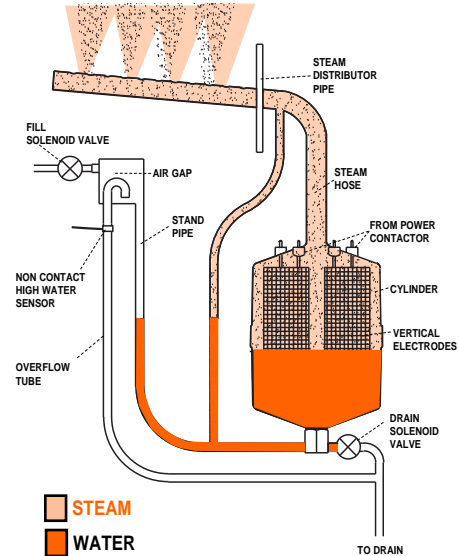

DISPLAY AND DIAGNOSTIC INFORMATION

FRONT PANEL DISPLAYS & CONTROLS

The display on the front panel of the humidifier cabinet contains the "On-Off-Drain" switch, the LCD True Touchscreen display and the "Fill", "Drain" and "High Water" LED's.



"ON-OFF-DRAIN" SWITCH
In the "On" position the humidifier will operate if

all controls are calling for humidity. The "Off" position is used for seasonal shutdown if desired. The "Drain" position is used to drain water from the steam cylinder for maintenance. The fill solenoid valve will be on whenever the drain is activated to reduce the drain water temperature.

LCD TRUE TOUCHSCREEN DISPLAY

This LCD True Touchscreen display offers the necessary interface to control and monitor many aspects of the humidifier. On the home screen is the current steam output in Lbs./Hr. (or Kg/Hr). To select either is available in the settings menu. A "Service Required" indicator and button outlining current service issues, indicators for the four basic controls necessary for operation (control humidistat, high limit humidistat, air flow switch and door interlock), and various buttons which navigate to other menu pages when pressed are also available on the home page screen. The menu pages and their capabilities are detailed further in "True Touchscreen Menu Pages" section of this document.

"FILL" LED:

The FILL LED is a blue light illuminated when the Fill Valve is activated. An activated Fill Valve allows water to flow into the cylinder of

the humidifier. An analogous indicator, and a description of its operation, is offered in the "Component Activity" menu.

"DRAIN" LED

The DRAIN LED is a red light illuminated when the Drain Valve is activated. An activated Drain Valve allows water to drain from the humidifier. An analogous indicator, and a description of its operation, is offered in the "Component Activity" menu.

"HIGH WATER" LED

The HIGH WATER LED is an orange light illuminated when the High Water Sensor is activated. An activated High Water Sensor indicates that the water has risen to the maximum allowable level in the cylinder. This can be a normal situation, particularly if the cylinder is being filled with mostly unconditioned water. An activated High Water Sensor can also be a sign that the cylinder is close to end-of-life and needs replacing, or, in rarer cases, the cylinder is not conductive enough for the fresh water entering the humidifier. An analogous indicator, and a description of its operation, is offered in the "Component Activity" menu. More information on troubleshooting High Water situations can also be found through the "Help" menu on the home screen.

ELECTRICAL DATA

Max. Sq. Ft. Humidified Area*	Carnes Model	Maximum Lb./Hr.	kW	Voltage	Phase	Line Amp Rating	Recommended Disconnect Size (Amps)	Cylinder
1400	HRABA U 005	5	1.7	120	1	14.4	20	HXCBA220
1400	HRABD U 005	5	1.7	230	1	7.5	15	HXCBA380
2800	HRABD U 010	10	3.4	230	1	15.0	20	HXCBA380

U = UL
C = cUL



*Based on average conditions. For complete load calculation, use our humidifier selection program.

CARNES STEAM HUMIDIFIERS are designed for quiet, efficient operation and are easy to install.

TYPICAL INSTALLATION

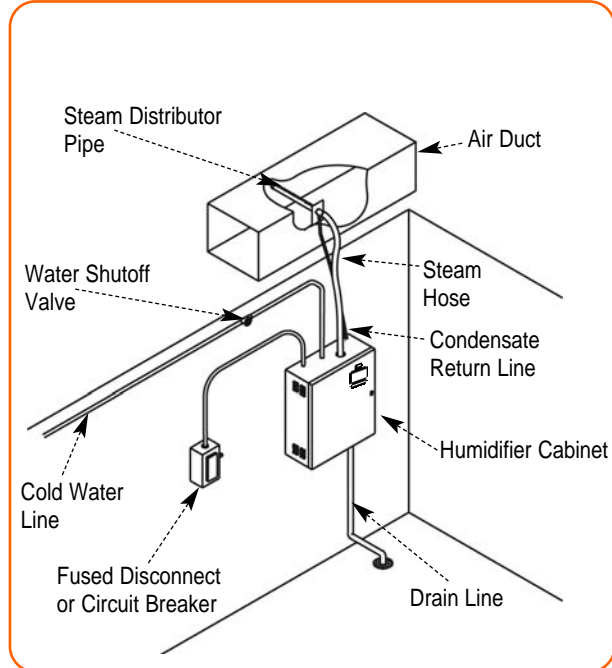

The **humidifier cabinet** with key locked door is usually located in area where other mechanical equipment such as a furnace or water heater is installed.

The unit must be connected through a **water shutoff valve** to a **cold water line** that is not treated by a water softener. Connections must be made to a 120 or 230 volt **fused disconnect** or **circuit breaker**. A **drain line** must be installed from the bottom of the humidifier to a convenient floor drain.

Steam is generated in the disposable plastic steam cylinder and transferred to the **steam distributor pipe** which must be located within 10 feet of the humidifier cabinet. Special **steam hose** is used to make the connection.

The steam is injected into the **air duct** to be distributed throughout the desired area. Any water that condenses within the distributor pipe is returned by a **condensate return line**.

The humidifier is controlled by a humidistat that can be located either in the humidified space or the return air duct. An air flow switch should be used to turn the humidifier off if there is no air moving in the duct where the steam is injected. A high limit humidistat may be used to prevent air in the duct from becoming too moist.

HUMIDIFIER DIMENSIONS

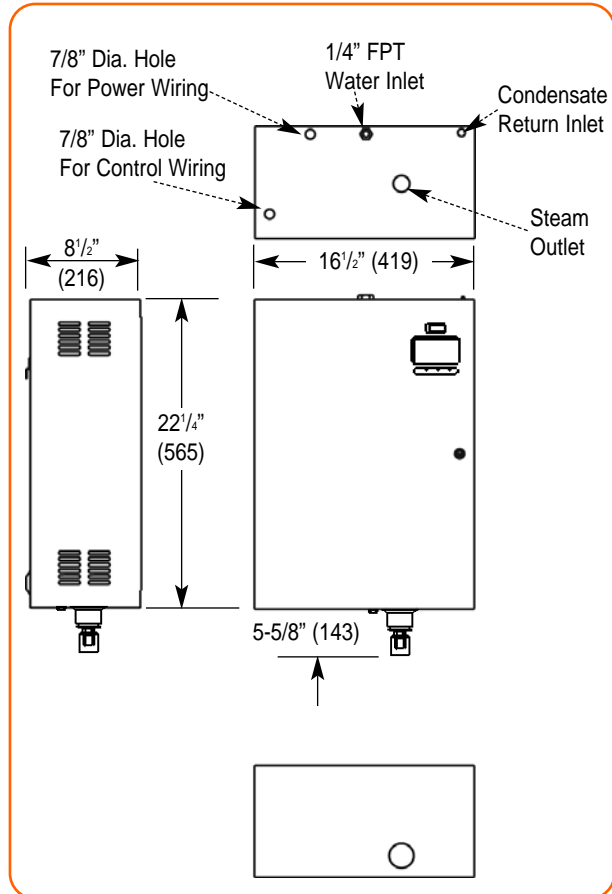

DISTRIBUTOR PIPE & HOSE DIMENSIONS

Carnes steam distributor pipes are fabricated from stainless steel.

Select the longest pipe that will fit into the duct.

DISTRIBUTOR PIPE MODEL	"N" DIMENSION
HXPBB012S	11-13/16" (300mm)
HXPBB018S	17-13/16" (452mm)
HXPBB024S	23-13/16" (605mm)

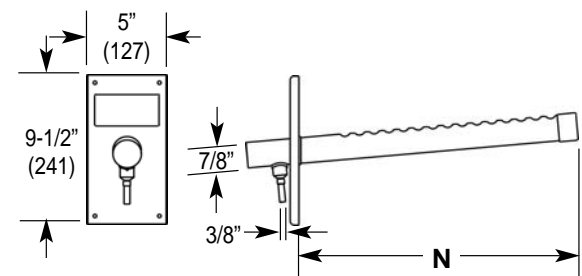

Carnes steam hose and condensate return line are available in either 5 or 10 foot lengths and may be field cut to the exact length needed. Both hoses are made from EPDM compound.

HOSE TYPE	MODEL	ID (Inches)	OD (Inches)
Steam	HXSAB	7/8"	1-3/16"
Condensate	HXRA	3/8"	5/8"

CARNES STEAM HUMIDIFIERS are available with a complete selection of accessories to provide accurate humidity control.

WALL HUMIDISTAT, PROPORTIONAL CONTROL

Model HXHAM



The Model HXHAM is a wall-mounted, microprocessor-controlled humidistat solution for cutting edge humidity control. The HXHAM employs a backlit LCD module, which displays both the ambient temperature and humidity of the surrounding air. The embedded software allows user navigation between temperature/humidity viewing mode and set-point adjustment mode and also outdoor temperature and humidity viewing mode. Set-point range is 0 to 100%. An optional outdoor temperature compensation sensor can be added (HXHAMT).

DUCT HUMIDISTAT, PROPORTIONAL CONTROL

Model HXHAN

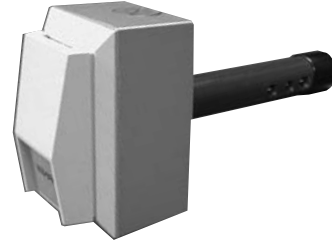

The Model HXHAN is an intelligent humidistat solution used exclusively for duct mounted installations. The humidistat is capable of providing both humidity and temperature measurements from inside the duct. The microprocessor control takes the temperature into consideration when calculating the humidity to provide an extra degree of precision. 0 to 100% set-point range.

WALL HUMIDISTAT, ON-OFF CONTROL

Model HXHAA



Mount this humidistat four or five feet above the floor in freely circulating air of the temperature and humidity about average for the entire space to be controlled. Avoid locations near hot or cold air ducts and discharge air from the humidifier. Scale range is from 10-90% RH. Differential is 5% non-adjustable. Case dimensions are 4-3/8" high, 2-7/8" wide and 1-5/8" deep including control knob.

DUCT HUMIDISTAT, ON-OFF CONTROL

Model HXHAB



This duct mounted humidistat is installed in the return air duct to sense the humidity level in the area being served. Scale range is 15-50% RH. Differential is 4-6% non-adjustable. Case dimensions are 3-3/4" high and 2-3/8" wide. The humidistat projects 2-1/2" outside of the duct and extends 7-1/2" into the duct.

WALL HUMIDISTAT, PROPORTIONAL CONTROL

Model HXHCG



The wall mounted HXHCG humidistat uses a special sensor and electronic circuit to modulate the output of the humidifier. The humidistat automatically adjusts the humidifier output to match the humidity requirements. This humidistat has a concealed set-point adjustment with a locking cover. Set-point range is from 10-90% RH. Case dimensions are 4-1/2" high, 2-13/16" wide and 1-1/4" deep.

DUCT HUMIDISTAT OR HIGH LIMIT, PROPORTIONAL CONTROL

Model HXHCH

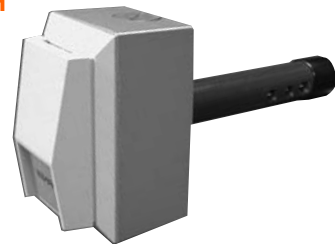

The model HXHCH can be mounted in either the return air duct when used to sense the humidity in the area being served or in the supply duct a minimum of 10 feet downstream of the steam distributor pipe when used as a high limit control. Set-point range is 10-90% RH. Case dimensions are 4-1/2" high and 2-13/16" wide. The humidistat projects 3-1/2" outside of the duct and extends 5-3/4" into the duct.

AIR FLOW SWITCH, PRESSURE DIFFERENTIAL TYPE

Model HXAAE



Air flow in the duct may be sensed by using this pressure differential switch. The differential in pressure between the interior and exterior of the duct closes a switch when air is moving. Air pressure differential as low as .07 w.g. may be sensed with this switch. Mounting plate dimensions are 4-3/4" wide, 5-1/8" high. The switch projects 4-3/8" outside the duct.

HIGH LIMIT HUMIDISTAT

Model HXHAD



The model HXHAD is available to reduce the potential of condensation occurring in the supply duct. The control must be mounted a minimum of 10 feet downstream of the steam distributor pipe. Set-point range is 15-95% RH. Differential is 5% non-adjustable. Mounting plate dimensions are 6-1/2" wide, 4-3/4" high. The humidistat projects 2-1/4" outside the duct and extends 1-1/4" into the duct.

OUTDOOR AIR TEMPERATURE COMPENSATED DIGITAL HUMIDISTAT, ON-OFF CONTROL

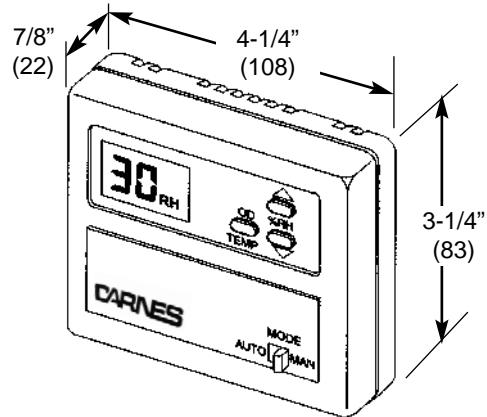

Model HXHAT

The HXHAT humidistat can be either wall or duct mounted and includes a remote outdoor temperature sensor for exterior wall or intake duct mounting. The humidistat can automatically change the set-point in response to changes in outdoor temperature or be set to maintain a set-point regardless of temperature changes. The LCD display shows set-point RH%, actual RH% or outdoor temperature (from -9 to 98°F). Relay contacts provide an on/off signal to the humidifier. Set-point range is from 30-65% RH. Default set-point is 40% RH.

The HXHAT will automatically reduce the RH set-point as the temperature drops below 35°F. The graph below shows the RH setting of 35° RH and as the temperature drops the RH set-point is adjusted by the computer as shown. Below -10° there is no adjustment.

