

READ AND SAVE THESE INSTRUCTIONS

CARNES®

**INSTALLATION and OPERATION MANUAL
FOR
FAN POWERED
TERMINAL UNITS**

CARNES COMPANY, 448 S. Main St., P.O. Box 930040, Verona, WI 53593-0040 Phone: 608/845-6411 Fax: 608/845-6470 carnes@carnes.com www.carnes.com

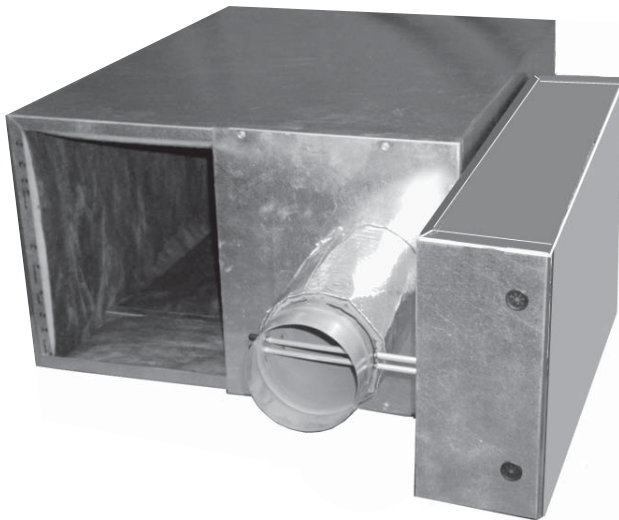

CONSTANT VOLUME (Series)

MODEL AC

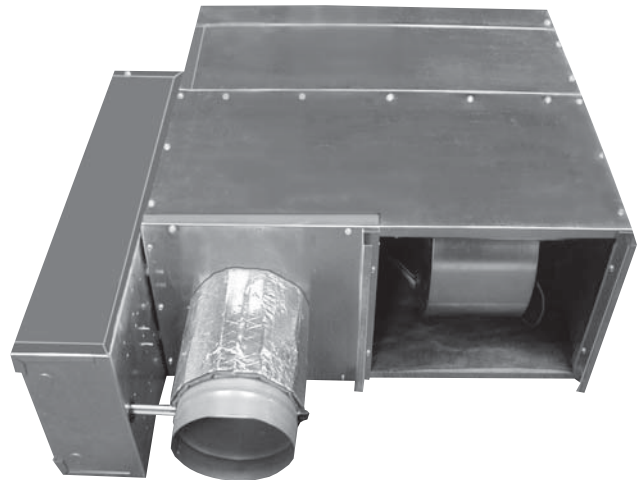

INTERMITTENT VOLUME (Parallel)

MODEL AS

CAUTION: *Completely Read All Instructions Prior To Attempting To Assemble, Install, Operate, Or Repair This Product!*

INSPECT UNIT

UNPACKING AND INSPECTION

1. Open shipping carton or crate and check for concealed shipping damage. Report damage immediately to the carrier that delivered the shipment.
2. Inspect the unit for loose or missing components.
3. Optional accessories may be packed within the unit or in the same shipping carton or crate.

INSTALLATION

CAUTION: *This Product Includes Vibration Producing Components. When Supporting Or Suspending Units, Use Good Industry Practice and Materials Suitable For Vibration Producing Equipment.*

GENERAL

1. Units are to be supported in a horizontal and level position. For convenience, it is suggested that units be installed prior to installation of the ceiling tile grid system.
2. Sufficient working space must be provided as per paragraph 110-16 of N. E. C.
3. Allow sufficient space for the removal of air filters and for the efficient flow of air into the secondary air inlet.
4. Avoid abrupt transitions or duct turns at the inlet of the unit that would alter the inlet cross-sectional area.
5. It is preferred that the installer attempt to obtain a minimum of three (3) inlet diameters of straight duct ahead of the terminal unit inlet to achieve optimum control accuracy.

DUCT CONNECTIONS

1. Units are provided with either slip and drive or flanged discharge duct connections depending upon model type.
2. It is suggested that discharge ductwork be lined with a minimum of 1/2" thick, 1-1/2 lb. density fiberglass insulation with an erosion resistant surface in accordance with NFPA 90A (non-residential type air conditioning and ventilating systems) to provide both thermal and acoustical insulation.

3. Sealing of ductwork to preclude air leaks should be done according to the job specifications.
4. It is recommended that units be **supported from underneath** using trapeze hangers and vibration isolators. Flexible connections are recommended for all connecting ductwork and electrical conduit to preclude the transmission of vibration noise.
5. It is recommended that flexible ductwork connected to the primary air inlet be secured using a compression band. Rigid duct should be slipped over the unit inlet, secured in place with sheet metal screws, and sealed according to the job specifications.

ELECTRICAL INSTALLATION

CAUTION: *All Sources Of Supply Power Must Be Disconnected Before Working On This Equipment. More Than One Disconnect May Be Required To De-Energize Equipment.*

1. Follow the wiring/piping diagram found on the inside of the fan unit control enclosure cover.
2. Supply connections must be made using wires rated for 75°C minimum. **DO NO USE ALUMINUM CONDUCTORS.**
3. If supply connections are for 250 volts or greater, all wiring must be insulated for 600V.

- Size supply conductors for 125% of rated combined load (fan motor FLA + heater current).

For electric heater use:

$$\begin{aligned} \text{Single phase Line Current} &= \frac{\text{KW} \times 1000}{\text{Voltage}} \\ \text{Three phase Line Current} &= \frac{\text{KW} \times 1000}{1.73 \times \text{Voltage}} \end{aligned}$$

- The following table shows the maximum current for 75°C Copper wire in conduit. Values are based on the 1984 N.E.C. Table 310-16 including note 8.

COMBINED LOAD MAXIMUM UNIT AMPERAGE		MINIMUM WIRE SIZES AWG/MCM
1 — 3 conductors	4 — 6 conductors	
12.0	9.6	14
16.0	12.8	12
24.0	19.2	10
40.0	32.0	8
48.0	38.4	6
--	48.0	4

- If not supplied as part of this unit, install a line disconnect and fusing or a circuit breaker in accordance with N. E. C.
- The following table shows the maximum over current rating for wire servicing unit.

MAXIMUM SUPPLY UNIT AMPERAGE	MAXIMUM OVERCURRENT RATING
12	15
16	20
20	25
24	30
28	35
32	40
36	45
40	50
48	60

- All field and factory made connections should be checked for tightness before operation.
- The unit must be wired so as to provide a fan relay interlock to preclude heater operation unless air is flowing over the heater. An interlock is factory wired if heaters are factory attached.

FAN UNIT CONTROLS (See Figure 1)

The following is a list of components located in the fan unit control panel. The figure at the right is to aid in component identification. Not all components are required for every control option and unit type.

- Air Flow Switch. (Constant Volume Units)
- Control Transformer. (Electronic/DDC Units)
- Fan Motor Capacitor(s).
- SCR Fan Speed Control.
- Fan Motor Relay.
- Fan Motor Disconnect Switch.
- Pressure/Electric Switch. (Pneumatic Units)
- Ground Lug.

Contact your local Carnes Representative for replacement parts.

CAUTION: Severe Electrical Shock May Occur. Disconnect All Sources Of Supply Power Before Working On This Equipment. More Than One Disconnect May Be Required To De-Energize Equipment For Servicing.

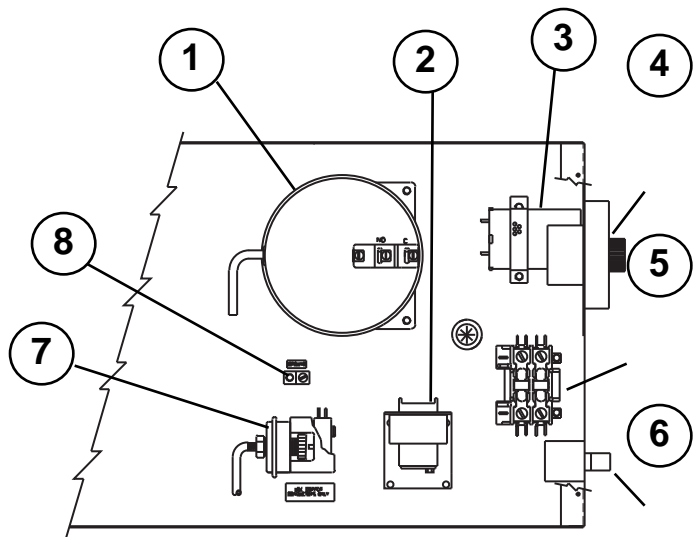

FAN UNIT CONTROL PANEL
Figure 1

BALANCING AND MAINTENANCE

DANGER: Severe Electrical Shock May Occur. Disconnect All Sources Of Supply Power Before Working On This Equipment. More Than One Disconnect May Be Required To De-Energize Equipment For Servicing.

SETTING SECONDARY (HEATING) AIR FLOW

CONSTANT VOLUME (AC UNITS)

1. Adjust room thermostat to call for full cool. (Damper should open to the maximum CFM setting of the controller).
2. Remove secondary air filter if provided.
3. Tape a piece of cardboard onto the secondary air inlet. Size the cardboard 1/2" less than the height and 1/2" less than the width of the secondary inlet opening allow it to swing freely when taped in place. (Figure 2)
4. Adjust fan speed control (SCR) until the cardboard taped onto the secondary inlet hangs vertically indicating a balance between primary inlet air and discharge air CFM.
5. Remove the cardboard from secondary inlet. Replace filter if provided.
6. Fan CFM **MUST NOT BE LESS** than the maximum cooling CFM. Overloading the fan could cause motor damage and primary air to be forced out of the secondary inlet.

INTERMITTENT VOLUME (AS UNITS)

1. Adjust room thermostat to call for full heat. (Damper should close to minimum CFM setting on the controller).
2. Adjust fan speed control (SCR) to design CFM as measured at the diffusers.

ROUTINE MAINTENANCE (To be done at least once a year)

1. Check all field and factory made electrical and pneumatic connections for tightness.
2. Clean all air filters. Throw-away air filters may be ordered through your local Carnes Representative. Aluminum mesh air filters may be washed in warm soapy water.
3. Check compressed air supply for clean, dry and oil free compressed air.

TAPE CARDBOARD OVER
SECONDARY AIR INLET
ALLOW TO SWING FREELY

Figure 2

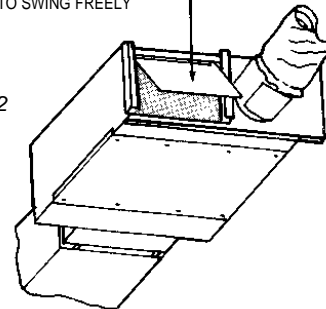

REMOVE (6) KEPS NUTS
FROM MOUNTING ANGLE
STUDS

Figure 3

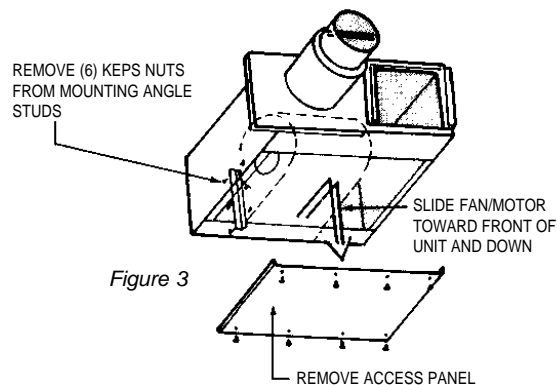

4. Fan motors are permanently lubricated not requiring annual service. If a fan wheel becomes out of balance due to dust or debris or if the fan motor should need replacing, follow the procedure outlined below.

FAN/MOTOR REMOVAL

1. Remove screws holding access panel in place.
2. Remove keps nuts from the mounting angle studs located on either side of the fan housing. (See Figure 3)
3. Disconnect fan motor wires from inside of the fan unit control panel.
4. Slide the fan/motor sub-assembly out through the access opening.
5. Reverse procedure for re-installation.

CARNES[®]
COMPANY

448 South Main Street
P. O. Box 930040
Verona, WI 53593-0040

Phone: 608/845-6411
Fax: 608/845-6470

carnes@carnes.com
www.carnes.com