

Models
ACFQ w/o Coil
ACWQ w/Hot Water Coil
ACEQ w/Electric Coil

The Carnes quiet constant volume fan terminals are designed for noise sensitive applications such as offices, theaters, schools and libraries. The constant volume fan runs continuously in the occupied mode, providing constant background sound to the space.

The primary air damper operates in the same manner as a standard throttling unit, except that all of the primary air is sent through the in-line (series) fan.

Integral sound baffles and isolated motor mounting ensure low sound levels throughout the air flow range.

Features Include:

- Air flow capacities to 2300 CFM.
- Durable 20 gauge galvanized steel casing construction.
- Bottom access panel for internal components.
- Flange or slip and drive discharge connections.
- Forward curved centrifugal type fan assemblies with thermally protected, Permanent Split Capacitor type 120 or 277 volt, single phase, fractional horsepower motors.
- Adjustable SCR fan speed control.
- Fan/motor assemblies are isolated from the casing using rubber isolators to minimize vibration transmission.
- Low leakage primary air damper design.
- Secondary air filter rack.
- Performance data based on tests conducted in accordance with AHRI Standard 880-2008.
- Air flow switch.
- All units are equipped with pressure independent pneumatic or electronic controls.
- Field adjustable P/E switch with pneumatic controls.
- Tri-Averaging type velocity sensor and calibration chart for measuring air flow through the primary air damper.
- Insulation is 1" thick, 1-1/2 lb. dual density fiberglass with surface treated to prevent air erosion, UL listed and meets NFPA 90A requirements.
- Damper controls and fan controls are located in one enclosure.
- AHRI listed.
- Optional ETL listing.
- Optional secondary air sound baffle. Sound baffle is factory attached to secondary air inlet. (Contact Carnes.)
- Optional one to four row hot water coils (Model ACW). Coil is factory attached to the unit discharge.
- Optional one or two stage electric reheat coils (Model ACE). Coil is factory attached to unit discharge.
- Optional secondary air filters, Class I (re-usable) or Class II (throw away).
- Optional non-fused or fused fan disconnect switch.
- Optional foil coated insulation (Hospital, Laboratory, etc. applications).
- Optional fiber-free liner.

Available Modules:

- Basic control unit — **Model ACFQ.**
- Basic control unit with hot water coil — **Model ACWQ.**
- Basic control unit with electric coil — **Model ACEQ.**

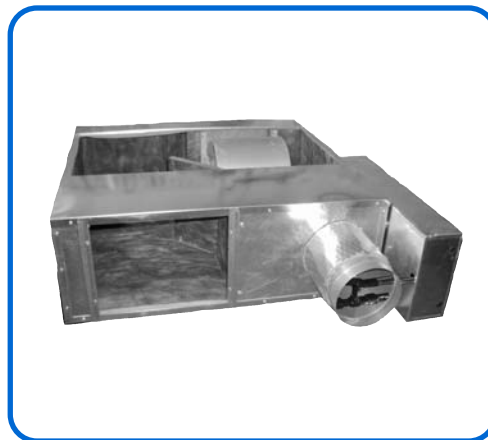

IAQ Insulation
Available

FAN CURVES CFM vs EXTERNAL STATIC PRESSURE

FAN SIZE A

AC_Q 05
1/6 H. P. Motor

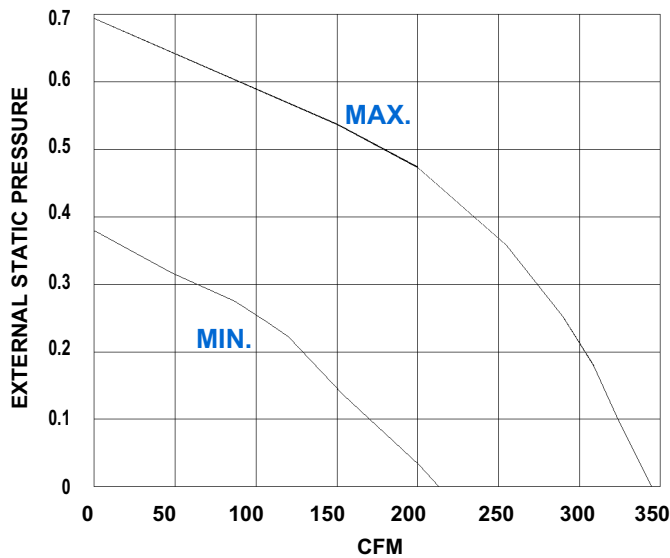

FAN SIZE B

AC_Q 06
1/6 H. P. Motor

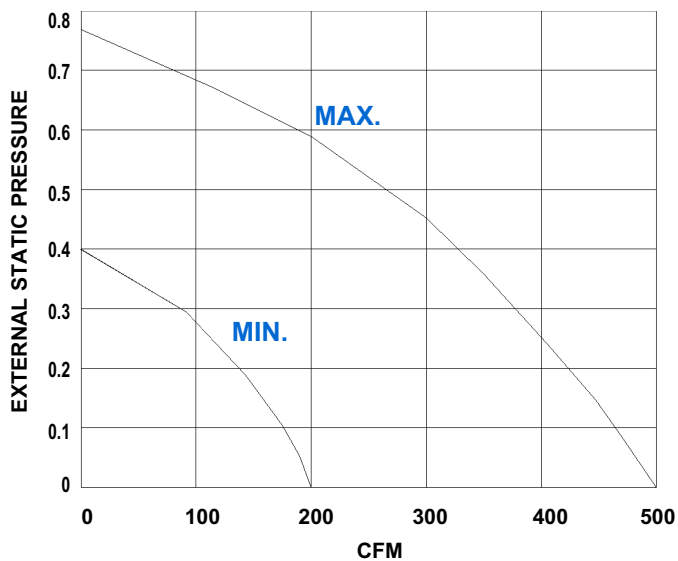

- NOTES:**
1. External static pressure (ESP) consists of down stream ductwork, coils, flex duct, etc.
 2. Pressure drops due to heating coils are treated as external static pressure .
 3. For proper operation, the downstream ESP must be at least 0.20" W. G.

FAN CURVES CFM vs EXTERNAL STATIC PRESSURE

FAN SIZE C

AC_Q 07
1/6 H. P. Motor

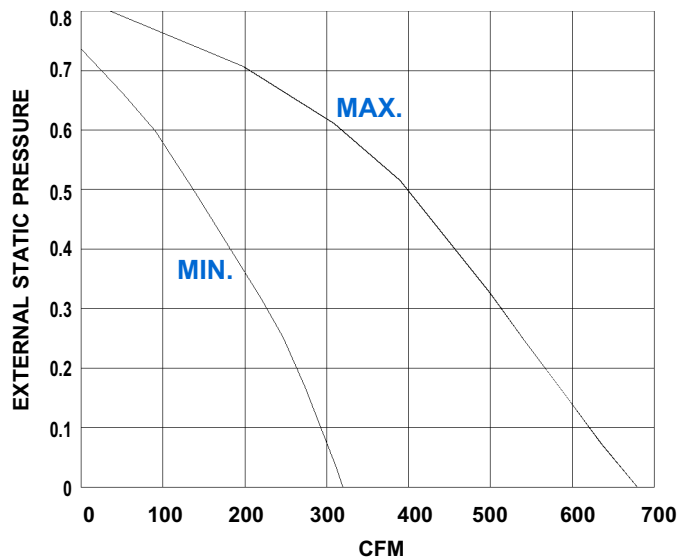

FAN SIZE D

AC_Q 08
1/4 H. P. Motor

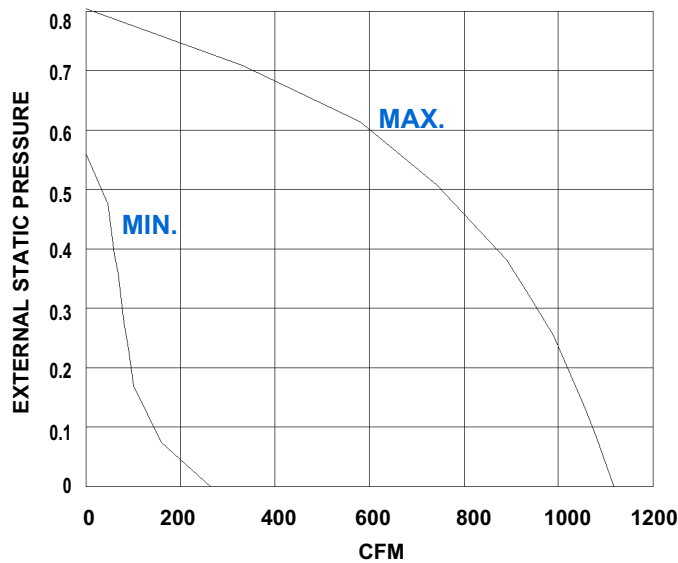

- NOTES:**
1. External static pressure (ESP) consists of down stream ductwork, coils, flex duct, etc.
 2. Pressure drops due to heating coils are treated as external static pressure .
 3. For proper operation, the downstream ESP must be at least 0.20" W. G.

FAN CURVES CFM vs EXTERNAL STATIC PRESSURE

FAN SIZE E

AC_Q 10
1/2 H. P. Motor

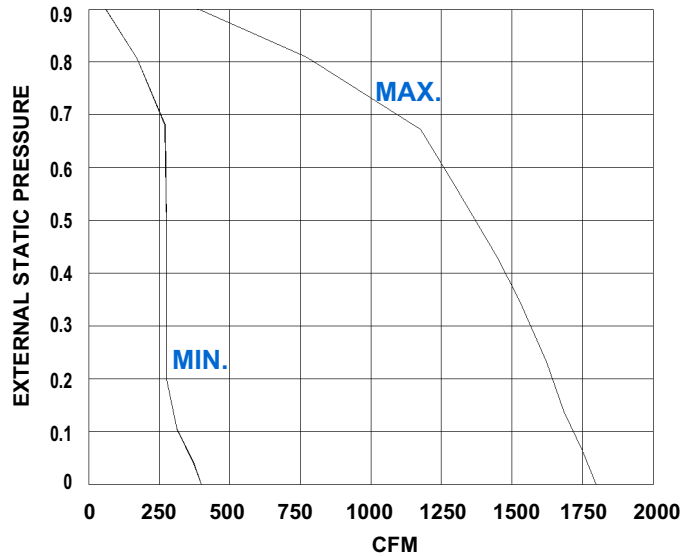

FAN SIZE F

AC_Q 12
3/4 H. P. Motor

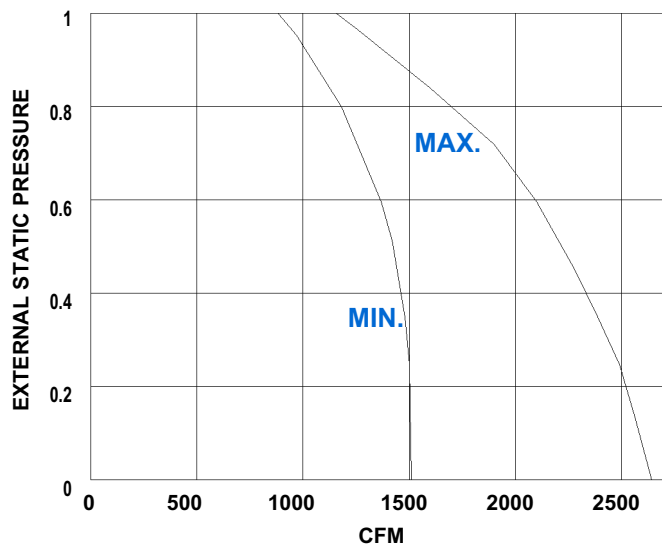

- NOTES:**
1. External static pressure (ESP) consists of down stream ductwork, coils, flex duct, etc.
 2. Pressure drops due to heating coils are treated as external static pressure .
 3. For proper operation, the downstream ESP must be at least 0.20" W. G.

Model AC _ Q 05A

(FAN ON — 100% Primary Air/Mixing/100% Secondary Air)

Primary/ Secondary CFM	Primary Air Δ Ps	Discharge Sound							Radiated Sound								
		Sound Power db							Max. NC	Sound Power db							Max. NC
		Octave Band								Octave Band							
2	3	4	5	6	7	NC	2	3	4	5	6	7	NC				
290/0	0.040	63	57	51	56	53	48	18	59	54	47	41	34	29	22		
	0.5	64	57	52	55	52	48	19	61	54	47	41	34	31	23		
	1	65	57	52	55	52	49	20	63	55	47	42	37	36	26		
	3	65	58	52	55	52	49	20	63	57	49	45	46	46	26		
145/145	0.5	60	54	50	53	50	46	14	55	50	46	39	32	29	20		
	1	62	55	51	54	51	48	17	58	53	46	41	35	34	21		
	3	62	56	52	54	51	48	17	58	54	47	44	45	44	22		
0/290	—	62	56	51	55	52	48	17	56	51	47	40	35	31	21		
200/0	0.153	57	51	47	49	45	40	10	54	49	43	37	28	25	16		
	0.5	58	51	47	49	45	40	11	56	49	43	37	29	26	17		
	1	58	51	47	48	36	40	11	57	50	43	38	34	32	18		
	3	59	53	49	48	45	42	13	58	52	45	42	45	44	19		
100/100	0.5	54	50	47	47	43	38	--	52	48	42	36	26	25	15		
	1	56	51	46	47	44	40	--	53	49	42	36	32	31	16		
	3	56	51	46	47	44	40	--	53	49	43	41	45	44	16		
0/200	—	57	51	48	48	44	40	10	51	47	42	36	25	25	15		
100/0	0	52	47	40	42	37	30	--	52	48	42	35	24	23	15		
	0.5	52	47	40	42	37	30	--	52	48	42	36	26	25	15		
	1	52	47	40	42	37	30	--	52	48	42	36	32	29	15		
	3	52	47	40	42	37	35	--	53	48	43	41	44	44	16		
50/50	0.5	51	45	38	39	34	27	--	52	48	42	35	25	23	15		
	1	51	46	39	41	36	30	--	52	48	43	36	32	31	16		
	3	52	46	41	42	37	34	--	52	48	43	40	44	44	16		
0/100	—	52	47	41	42	37	31	--	52	48	42	35	24	23	15		

- NOTES:**
1. Δ Ps static pressure difference from inlet to discharge.
 2. The lowest value of Δ Ps is the minimum pressure required to deliver CFM shown with primary damper in wide open position.
 3. Δ Ps does not include hot water or electric coils.
 4. (--) indicates NC levels less than 10.

NC Levels are derived from tests conducted in accordance with AHRI Standard 880-2008 and are calculated in accordance with AHRI Standard 885-2008 as application data based on the following:

Discharge NC levels are based on —

- a) 5 foot rectangular duct lined with 1" fiberglass insulation.
- b) 5 foot lined flex duct (8" diameter).
- c) Flow division.
- d) Space effect factor (2400ft³) at 5 feet from outlet.
- e) End reflection.
- f) Environmental adjustment factor.

Radiated NC levels are based on —

- a) Plenum/ceiling effect - 5/8" mineral fiber tile, 35 lb/ft³ - 3 foot plenum
- b) Environmental adjustment factor.

NC is not part of the AHRI 880 Certification Program.

Model AC _ Q 06B

(FAN ON — 100% Primary Air/Mixing/100% Secondary Air)

Primary/ Secondary CFM	Primary Air Δ Ps	Discharge Sound							Radiated Sound								
		Sound Power db							Max. NC	Sound Power db							Max. NC
		Octave Band								Octave Band							
2	3	4	5	6	7	2	3	4	5	6	7						
400/0	0.069	70	61	57	61	59	56	23	63	56	52	46	39	37	26		
	0.5	70	62	58	62	59	57	23	64	57	52	47	39	37	27		
	1	70	63	58	62	59	57	23	65	58	53	47	41	39	28		
	3	71	64	59	62	60	58	24	65	60	54	49	46	45	29		
200/200	0.5	69	61	58	61	58	56	26	61	55	52	46	39	37	26		
	1	69	61	58	61	58	56	26	63	56	52	46	40	38	26		
	3	69	62	58	62	59	56	26	63	57	53	48	45	44	27		
0/200	—	69	62	59	63	59	57	22	63	57	53	47	39	37	27		
250/0	0.185	61	54	49	53	49	44	15	56	50	46	39	31	27	20		
	0.5	61	54	49	53	49	46	15	56	50	46	39	32	28	20		
	1	62	55	50	53	49	46	17	56	50	46	40	35	33	20		
	3	62	55	50	53	49	46	17	57	52	49	44	45	43	23		
125/125	0.5	62	54	50	53	49	46	17	54	49	46	39	32	28	20		
	1	62	55	50	53	49	46	17	54	49	46	39	33	31	20		
	3	62	55	51	54	50	47	17	55	50	47	42	44	43	21		
0/250	—	61	54	50	53	49	46	15	53	49	46	39	31	27	20		
120/0	0.224	53	47	41	43	37	31	--	52	47	42	33	24	21	15		
	0.5	52	47	41	43	37	31	--	52	47	44	36	28	24	18		
	1	52	47	41	43	37	33	--	52	47	44	36	32	30	18		
	3	53	48	43	44	39	36	--	52	47	44	41	44	43	18		
60/60	0.5	55	48	43	44	39	35	--	53	49	44	36	28	24	18		
	1	53	47	43	44	39	35	--	53	49	44	36	32	30	18		
	3	53	47	42	43	37	24	--	54	49	45	41	44	45	19		
0/120	—	53	48	42	44	39	35	--	54	49	44	36	28	24	18		

- NOTES:**
1. Δ Ps static pressure difference from inlet to discharge.
 2. The lowest value of Δ Ps is the minimum pressure required to deliver CFM shown with primary damper in wide open position.
 3. Δ Ps does not include hot water or electric coils.
 4. (--) indicates NC levels less than 10.

NC Levels are derived from tests conducted in accordance with AHRI Standard 880-2008 and are calculated in accordance with AHRI Standard 885-2008 as application data based on the following:

Discharge NC levels are based on —

- a) 5 foot rectangular duct lined with 1" fiberglass insulation.
- b) 5 foot lined flex duct (8" diameter).
- c) Flow division.
- d) Space effect factor (2400ft³) at 5 feet from outlet.
- e) End reflection.
- f) Environmental adjustment factor.

Radiated NC levels are based on —

- a) Plenum/ceiling effect - 5/8" mineral fiber tile, 35 lb/ft³ - 3 foot plenum
- b) Environmental adjustment factor.

NC is not part of the AHRI 880 Certification Program.

Fan Powered Units

Model AC _ Q 07C

(FAN ON — 100% Primary Air/Mixing/100% Secondary Air)

Primary/ Secondary CFM	Primary Air Δ Ps	Discharge Sound							Radiated Sound								
		Sound Power db							Max. NC	Sound Power db							Max. NC
		Octave Band								Octave Band							
2	3	4	5	6	7	NC	2	3	4	5	6	7	NC				
530/0	0.132	75	67	62	67	65	62	33	70	63	56	51	44	41	33		
	0.5	75	67	62	67	64	62	33	70	63	56	51	44	41	35		
	1	75	67	62	68	65	63	33	70	63	56	51	45	43	36		
	3	76	68	62	68	65	63	35	71	64	57	52	48	46	39		
265/265	0.5	76	67	62	68	65	62	35	69	63	55	52	44	42	33		
	1	76	67	62	68	65	62	35	69	63	56	52	44	42	33		
	3	76	67	62	68	65	62	35	69	63	56	52	48	46	33		
0/530	—	75	67	62	68	64	62	33	69	64	56	52	44	41	32		
400/0	0.188	67	61	57	60	57	54	23	63	57	51	46	38	35	26		
	0.5	70	62	59	62	59	56	27	64	58	51	46	39	36	30		
	1	70	62	59	63	59	57	27	66	60	52	47	40	38	31		
	3	71	64	59	63	60	58	28	67	61	54	49	46	45	31		
200/200	0.5	69	63	58	62	59	56	26	63	57	51	46	39	38	30		
	1	71	63	58	62	59	57	28	64	57	51	47	40	38	27		
	3	71	64	58	62	59	57	28	64	58	52	48	46	44	27		
0/400	—	70	63	59	62	59	56	27	65	59	52	47	40	38	29		
250/0	0.267	58	52	47	50	45	41	11	53	49	44	38	31	27	21		
	0.5	58	52	47	50	46	42	11	54	50	45	38	31	28	22		
	1	58	52	48	51	46	43	11	55	51	46	39	34	31	23		
	3	59	54	49	52	46	43	13	57	53	48	44	45	43	26		
125/125	0.5	57	51	46	49	45	40	10	54	50	45	37	31	28	22		
	1	57	52	47	50	45	40	10	54	50	45	38	33	31	22		
	3	58	52	47	51	46	42	11	54	51	46	42	44	43	23		
0/250	—	59	54	48	50	46	42	13	54	50	44	37	29	27	21		

- NOTES:**
1. Δ Ps static pressure difference from inlet to discharge.
 2. The lowest value of Δ Ps is the minimum pressure required to deliver CFM shown with primary damper in wide open position.
 3. Δ Ps does not include hot water or electric coils.
 4. (-) indicates NC levels less than 10.

NC Levels are derived from tests conducted in accordance with AHRI Standard 880-2008 and are calculated in accordance with AHRI Standard 885-2008 as application data based on the following:

Discharge NC levels are based on —

- a) 5 foot rectangular duct lined with 1" fiberglass insulation.
- b) 5 foot lined flex duct (8" diameter).
- c) Flow division.
- d) Space effect factor (2400ft³) at 5 feet from outlet.
- e) End reflection.
- f) Environmental adjustment factor.

Radiated NC levels are based on —

- a) Plenum/ceiling effect - 5/8" mineral fiber tile, 35 lb/ft³ - 3 foot plenum
- b) Environmental adjustment factor.

NC is not part of the AHRI 880 Certification Program.

Model AC _ Q 08D

(FAN ON — 100% Primary Air/Mixing/100% Secondary Air)

Primary/ Secondary CFM	Primary Air ΔP_s	Discharge Sound							Radiated Sound								
		Sound Power db							Max. NC	Sound Power db							Max. NC
		Octave Band								Octave Band							
2	3	4	5	6	7	NC	2	3	4	5	6	7	NC				
1000/0	0.140	73	70	69	71	67	65	29	68	66	59	54	46	45	36		
	0.5	76	71	67	70	66	64	29	71	67	59	53	46	45	37		
	1	76	71	67	70	65	64	29	71	67	59	53	46	45	37		
	3	77	72	67	70	66	64	30	72	68	61	55	49	48	38		
500/500	0.5	73	68	66	69	64	63	27	67	65	58	53	44	44	35		
	1	73	68	66	69	64	63	27	68	65	58	54	45	45	35		
	3	73	68	66	69	65	63	27	69	66	59	54	48	47	36		
0/1000	—	72	66	65	69	64	62	26	68	65	58	54	45	44	35		
750/0	0.156	67	62	60	61	58	56	20	63	60	53	45	38	37	29		
	0.5	71	65	63	65	61	59	23	65	62	55	49	41	40	31		
	1	71	65	63	65	61	59	23	66	63	56	50	42	41	33		
	3	72	67	64	66	62	60	24	67	65	58	53	47	46	35		
375/375	0.5	69	63	62	63	59	57	22	64	61	54	48	39	39	30		
	1	69	63	62	64	60	58	22	65	61	55	48	41	40	30		
	3	70	64	63	64	60	58	23	65	62	56	52	46	45	31		
0/750	—	69	62	62	63	58	56	20	62	61	53	47	39	39	30		
500/0	0.216	60	53	51	52	48	44	10	57	54	46	39	31	28	22		
	0.5	64	58	56	56	52	50	15	60	56	49	42	34	33	24		
	1	64	58	56	56	52	50	15	61	57	50	43	37	35	25		
	3	65	59	57	57	53	51	17	62	60	55	49	46	44	30		
250/250	0.5	62	56	55	55	51	48	17	57	55	48	41	33	31	23		
	1	63	56	55	55	51	48	18	57	55	48	42	35	33	23		
	3	63	57	55	55	52	49	18	59	56	51	47	45	43	25		
0/500	—	63	56	55	55	51	48	14	58	54	48	39	31	30	22		

- NOTES:**
1. ΔP_s static pressure difference from inlet to discharge.
 2. The lowest value of ΔP_s is the minimum pressure required to deliver CFM shown with primary damper in wide open position.
 3. ΔP_s does not include hot water or electric coils.
 4. (--) indicates NC levels less than 10.

NC Levels are derived from tests conducted in accordance with AHRI Standard 880-2008 and are calculated in accordance with AHRI Standard 885-2008 as application data based on the following:

Discharge NC levels are based on —

- a) 5 foot rectangular duct lined with 1" fiberglass insulation.
- b) 5 foot lined flex duct (8" diameter).
- c) Flow division.
- d) Space effect factor (2400ft³) at 5 feet from outlet.
- e) End reflection.
- f) Environmental adjustment factor.

Radiated NC levels are based on —

- a) Plenum/ceiling effect - 5/8" mineral fiber tile, 35 lb/ft³ - 3 foot plenum
- b) Environmental adjustment factor.

NC is not part of the AHRI 880 Certification Program.

Fan Powered Units

Model AC _ Q 10E

(FAN ON — 100% Primary Air/Mixing/100% Secondary Air)

Primary/ Secondary CFM	Primary Air Δ Ps	Discharge Sound							Radiated Sound								
		Sound Power db							Max. NC	Sound Power db							Max. NC
		Octave Band								Octave Band							
2	3	4	5	6	7	NC	2	3	4	5	6	7	NC				
1600/0	0.012	77	75	72	75	71	69	34	71	66	59	53	48	47	36		
	0.5	77	74	69	71	67	69	33	72	66	59	53	48	47	37		
	1	77	73	68	70	67	66	31	73	67	60	54	48	47	39		
	3	78	73	68	69	67	65	31	75	68	62	55	51	49	41		
800/800	0.5	76	73	69	71	67	65	31	71	63	58	52	46	45	36		
	1	76	73	68	70	67	65	31	72	63	58	52	46	45	37		
	3	76	73	68	70	67	65	31	72	67	61	55	49	48	37		
0/1600	—	74	74	71	74	70	70	33	68	63	59	55	48	48	34		
1300/0	0.075	71	70	67	67	64	63	28	68	60	55	49	44	42	32		
	0.5	73	71	67	68	65	64	29	71	64	57	51	45	44	36		
	1	74	71	67	68	65	63	29	71	65	58	51	46	45	36		
	3	75	72	67	68	65	63	30	72	66	60	53	50	48	37		
650/650	0.5	74	71	66	67	64	63	30	67	62	55	50	44	43	31		
	1	74	71	66	67	64	63	30	68	62	56	50	45	43	32		
	3	74	71	67	68	64	63	30	70	63	59	54	48	47	35		
0/1300	—	68	67	65	65	63	62	26	65	59	54	49	43	42	28		
1000/0	0.134	64	64	60	60	57	56	21	64	55	51	45	39	38	27		
	0.5	72	69	65	66	62	61	27	67	61	55	49	43	42	31		
	1	72	69	65	66	63	62	27	69	62	55	49	44	43	33		
	3	74	70	65	66	63	61	28	70	65	59	52	48	47	35		
500/500	0.5	70	68	64	65	61	60	27	65	60	53	48	42	41	29		
	1	71	68	64	66	62	61	27	65	60	55	49	43	42	30		
	3	71	68	65	65	62	61	27	67	61	56	53	48	45	31		
0/1000	—	65	62	60	59	57	55	19	63	57	51	45	39	38	26		

- NOTES:**
1. Δ Ps static pressure difference from inlet to discharge.
 2. The lowest value of Δ Ps is the minimum pressure required to deliver CFM shown with primary damper in wide open position.
 3. Δ Ps does not include hot water or electric coils.
 4. (-) indicates NC levels less than 10.

NC Levels are derived from tests conducted in accordance with AHRI Standard 880-2008 and are calculated in accordance with AHRI Standard 885-2008 as application data based on the following:

Discharge NC levels are based on —

- a) 5 foot rectangular duct lined with 1" fiberglass insulation.
- b) 5 foot lined flex duct (8" diameter).
- c) Flow division.
- d) Space effect factor (2400ft³) at 5 feet from outlet.
- e) End reflection.
- f) Environmental adjustment factor.

Radiated NC levels are based on —

- a) Plenum/ceiling effect - 5/8" mineral fiber tile, 35 lb/ft³ - 3 foot plenum
- b) Environmental adjustment factor.

NC is not part of the AHRI 880 Certification Program.

Model AC _ Q 12F

(FAN ON — 100% Primary Air/Mixing/100% Secondary Air)

Primary/ Secondary CFM	Primary Air ΔP_s	Discharge Sound							Radiated Sound								
		Sound Power db							Max. NC	Sound Power db							Max. NC
		Octave Band								Octave Band							
2	3	4	5	6	7	NC	2	3	4	5	6	7	NC				
2450/0	0.116	77	76	74	77	74	73	36	77	73	65	61	56	54	44		
	0.5	77	76	74	76	74	73	36	79	74	65	60	55	53	46		
	1	79	77	74	76	74	73	36	79	74	65	59	55	52	46		
	3	79	77	74	76	74	73	36	79	75	67	61	57	55	47		
1225/1225	0.5	78	77	74	78	73	73	36	78	74	64	61	55	53	46		
	1	79	77	74	78	74	73	36	78	74	65	61	55	53	46		
	3	79	77	74	76	74	73	36	79	75	66	61	56	54	47		
0/2450	—	76	75	73	77	73	72	35	77	73	64	61	56	53	44		
1950/0	0.128	68	68	68	67	64	63	27	69	64	58	52	46	44	34		
	0.5	74	72	70	71	68	68	31	75	70	62	57	51	49	41		
	1	75	74	70	72	69	69	33	76	71	62	57	52	50	43		
	3	75	74	70	72	70	69	33	77	72	65	58	54	52	44		
975/975	0.5	72	72	69	71	67	67	30	71	67	59	54	48	46	37		
	1	74	72	70	72	68	68	31	71	67	60	54	49	47	37		
	3	76	73	70	72	69	68	31	71	67	61	57	51	49	37		
0/1950	—	70	68	68	69	65	65	29	70	66	59	53	48	46	36		
1050/0	0.239	65	62	60	58	54	52	18	61	61	58	45	39	37	33		
	0.5	67	68	64	64	61	60	25	69	64	58	49	44	42	34		
	1	69	69	65	65	62	61	27	70	66	58	50	45	43	36		
	3	70	68	66	66	63	62	26	70	67	62	56	49	48	37		
525/525	0.5	65	65	63	62	58	57	23	66	63	58	48	42	40	33		
	1	65	66	64	63	60	58	24	67	63	58	49	43	41	33		
	3	65	66	64	63	60	58	24	67	63	59	52	47	46	34		
0/1050	—	62	62	63	61	57	55	19	65	61	57	47	41	37	32		

- NOTES:**
1. ΔP_s static pressure difference from inlet to discharge.
 2. The lowest value of ΔP_s is the minimum pressure required to deliver CFM shown with primary damper in wide open position.
 3. ΔP_s does not include hot water or electric coils.
 4. (--) indicates NC levels less than 10.

NC Levels are derived from tests conducted in accordance with AHRI Standard 880-2008 and are calculated in accordance with AHRI Standard 885-2008 as application data based on the following:

Discharge NC levels are based on —

- a) 5 foot rectangular duct lined with 1" fiberglass insulation.
- b) 5 foot lined flex duct (8" diameter).
- c) Flow division.
- d) Space effect factor (2400ft³) at 5 feet from outlet.
- e) End reflection.
- f) Environmental adjustment factor.

Radiated NC levels are based on —

- a) Plenum/ceiling effect - 5/8" mineral fiber tile, 35 lb/ft³ - 3 foot plenum
- b) Environmental adjustment factor.

NC is not part of the AHRI 880 Certification Program.

Fan Powered Units

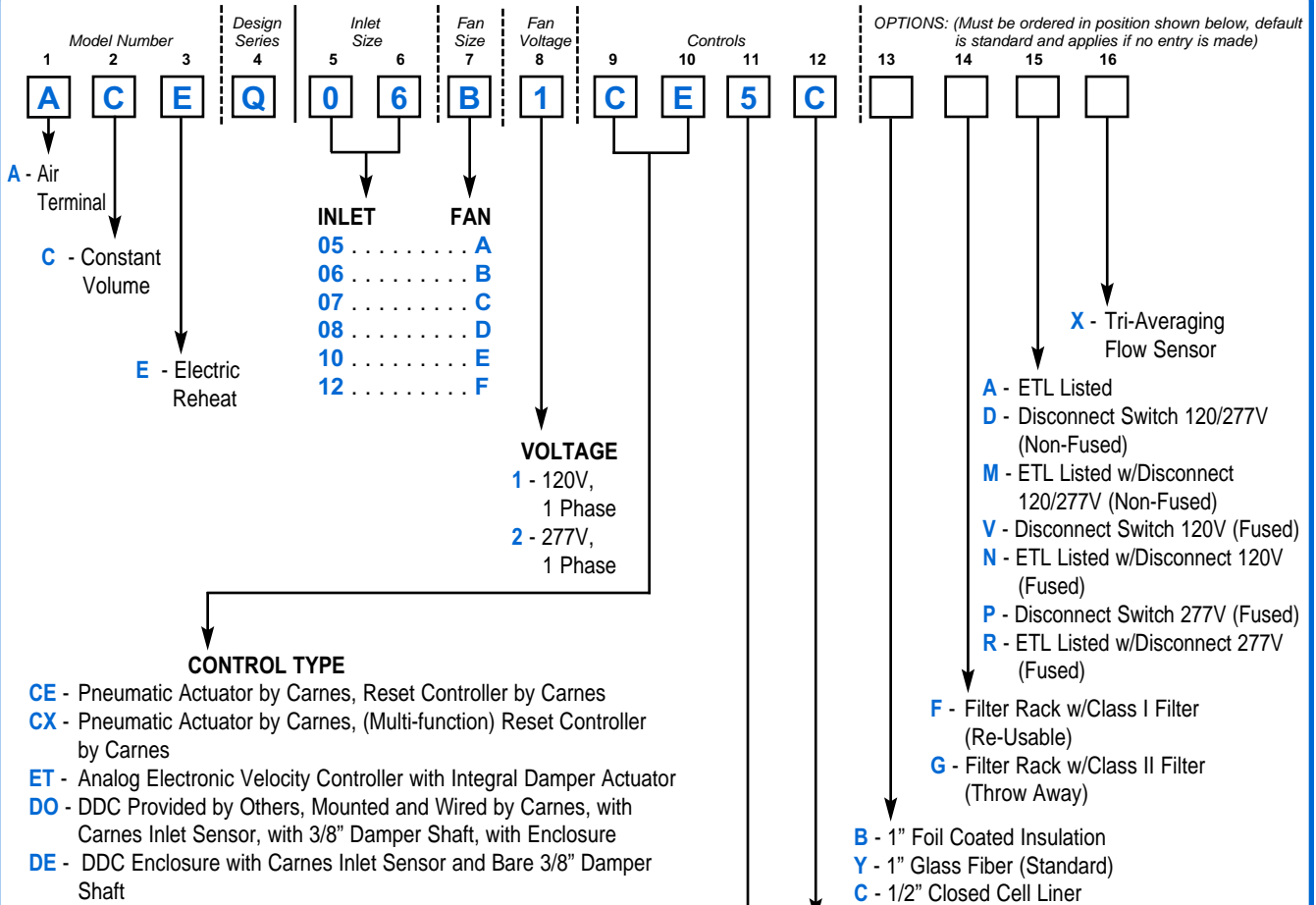

CONTROL TYPE

- CE** - Pneumatic Actuator by Carnes, Reset Controller by Carnes
- CX** - Pneumatic Actuator by Carnes, (Multi-function) Reset Controller by Carnes
- ET** - Analog Electronic Velocity Controller with Integral Damper Actuator
- DO** - DDC Provided by Others, Mounted and Wired by Carnes, with Carnes Inlet Sensor, with 3/8" Damper Shaft, with Enclosure
- DE** - DDC Enclosure with Carnes Inlet Sensor and Bare 3/8" Damper Shaft

NOTE: Hand of controls is determined by facing the averaging flow sensor (inlet of the unit) with the supply air hitting the back of your head.

▼ Electronic Thermostat

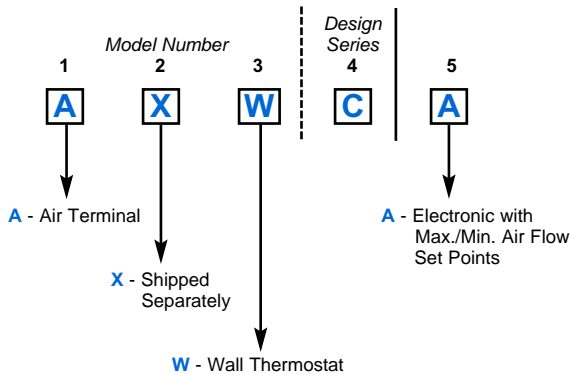

A Carnes Electronic Thermostat **must be ordered** with the ET Electronic Control Option.

ACTUATOR VENDOR

- C** - Carnes OEM (Pneu. or Elec.)
- D** - DDC Actuator (DO Option Only)
- N** - Not Applicable (DE Option Only)

CONTROLS AND DAMPER ARRANGEMENT

- *1** - Normally Open - Right Hand Controls (Electronic/DO, DE, ET) (All Pneumatic Control Types for Reverse Acting Thermostat)
- *2** - Normally Open - Left Hand Controls (Electronic/DO, DE, ET) (All Pneumatic Control Types for Reverse Acting Thermostat)
- 3** - Normally Closed - Right Hand Controls (All Pneumatic Control Types for Direct Acting Thermostat)
- 4** - Normally Closed - Left Hand Controls (All Pneumatic Control Types for Direct Acting Thermostat)
- 5** - Normally Open - Right Hand Controls (All Pneumatic Control Types for Direct Acting Thermostat)
- 6** - Normally Open - Left Hand Controls (All Pneumatic Control Types for Direct Acting Thermostat)
- 7** - Normally Closed - Right Hand Controls (All Pneumatic Control Types for Reverse Acting Thermostat)
- 8** - Normally Closed - Left Hand Controls (All Pneumatic Control Types for Reverse Acting Thermostat)

* Electronic and DDC Units **DO NOT** fail open. '1' or '2' is used for Right or Left Hand Only. Electronic Units are shipped with the Damper in the Open Position.

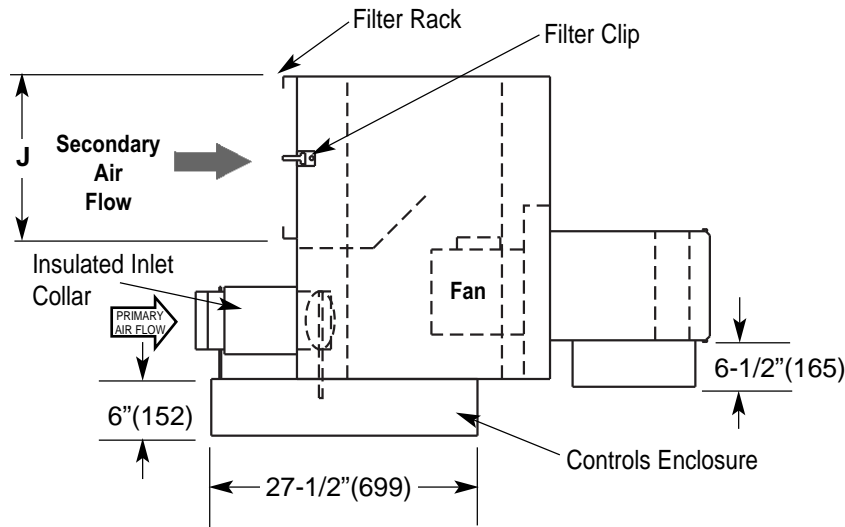

RIGHT HAND PRIMARY AIR UNIT SHOWN. LEFT HAND AVAILABLE.

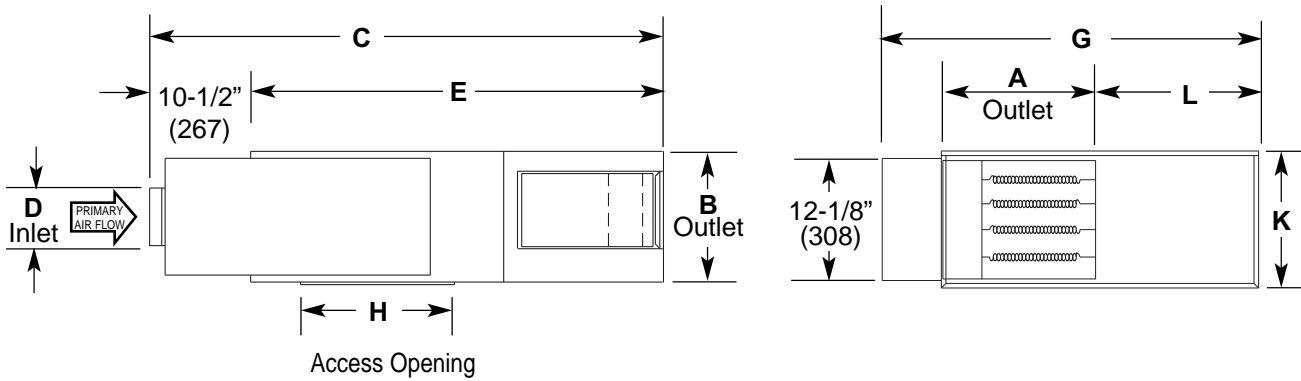

Dimensions Listed in Inches (Millimeters)															
Fan Size	Inlet Size	Primary CFM (L/s)	Secondary CFM (L/s) @ .25" E.S.P.	Fan H.P.	Outlet		C	Inlet		E	G	H	J	K	L
					A	B		D							
A	05	350(165)	290(137)	1/6	14 (356)	14 (356)	73-1/2 (1866)	4-7/8(124)	61 (1549)	46 (1168)	20 (508)	17-1/4 (438)	14 (356)	20-3/4 (527)	
B	06	500(236)	400(189)	1/6				5-7/8(149)							
C	07	700(330)	540(255)	1/6				6-7/8(175)							
D	08	1000(472)	1000(472)	1/4				7-7/8(200)							
E	10	1500(708)	1600(755)	1/2	14 (356)	17-1/2(445)	79-3/4 (2025)	9-7/8(251)	67-1/4 (1708)	54 (1372)	24 (610)	21(533)	17-1/2(445)	27-1/2(699)	
F	12	2300(1085)	2450(1156)	3/4	16 (406)	20-1/8(511)	11-7/8 (302)	11-7/8 (302)				21(533)	20-1/8(511)	27-1/2(699)	

Note: Outlet is designed for slip and drive duct connection.