

Models **ACF w/o Reheat**
 ACW w/ Hot Water Reheat
 ACE w/ Electric Reheat

The **Carnes** underfloor constant volume fan terminal unit provides constant air volume to the space while retaining the advantages of a variable air volume system. The primary air control assembly operates in the same manner as a standard throttling control valve when cooling loads are high. As cooling loads diminish the integral blower induces warm ceiling plenum air to maintain constant air volume.

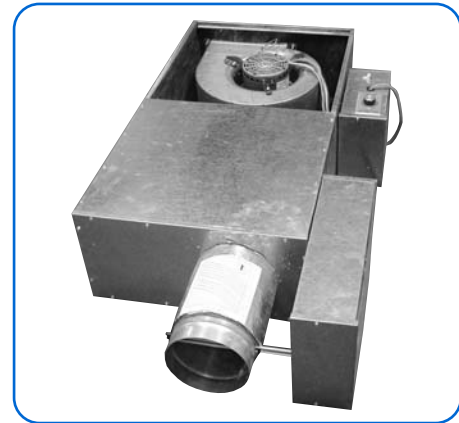

Features Include:

- Air flow capacities to 1525 CFM.
- Durable 22 gauge galvanized steel casing construction.
- Access panel for internal components.
- Standard inlet sizes and flange or slip and drive discharge connections.
- Forward curved centrifugal type fan assemblies with 120 or 277 volt, single phase, fractional horsepower PSC motors.
- Low leakage primary air damper design.
- Secondary air filter rack.
- Performance data based on tests conducted in accordance with ARI Standard 880-98.
- Pressure independent pneumatic or electronic controls available.
- Field adjustable P/E switch with pneumatic controls.
- Averaging type velocity sensor and calibration chart for measuring air flow through the primary air damper.
- Insulation is 1/2" thick, 2.0 lb. dual density fiberglass with surface treated to prevent air erosion, UL listed and meets NFPA 90A requirements.
- Optional primary air controls enclosure.
- Optional one or two row hot water coils (Model ACW). Coil is factory attached to the unit discharge.
- Optional electric reheat coils (Model ACE). Coil is factory attached to unit discharge or shipped separately for field mounting.
- Optional secondary air filters, Class I (re-usable) or Class II (throw away).
- Optional foil coated insulation (Hospital, Laboratory, etc. applications).
- Optional ETL listing.

Available Modules:

- Basic control unit — **Model ACF.**
- Basic control unit with hot water coil — **Model ACW.**
- Basic control unit with electric coil — **Model ACE.**



A Participating Member
 in the ARI 880
 Certification Program

UNIT SIZE - U1
Inlet Size - 5"

(FAN ON — 100% Primary Air/Mix/100% Secondary Air)

Primary/ Secondary CFM	Primary Air ΔP_s	Discharge Sound							Max. NC	Radiated Sound							Max. NC
		Sound Power db Octave Band								Sound Power db Octave Band							
		2	3	4	5	6	7	2		3	4	5	6	7			
290/0	.29	57	54	54	51	45	39	11	58	54	50	45	36	29	19		
	.50	61	55	56	54	47	40	15	60	54	52	49	39	30	21		
	1.00	60	56	58	56	49	41	14	60	56	55	51	42	35	24		
	1.50	62	57	59	57	50	41	17	63	57	57	52	46	40	26		
	3.00	64	59	60	59	51	43	19	63	58	59	51	49	45	28		
150/150	.50	53	50	52	50	43	36	-	54	47	45	43	35	24	14		
	1.00	53	50	52	50	44	37	-	54	48	47	44	39	34	15		
	1.50	53	51	53	51	45	38	-	54	50	48	46	42	40	17		
	3.00	54	52	54	52	46	39	-	55	51	51	49	48	48	23		
0/290	—	51	48	52	50	42	35	-	53	45	44	44	32	21	15		
150/0	.07	47	43	44	40	31	22	-	52	45	41	38	27	20	—		
	.50	51	46	48	43	33	23	-	52	46	43	41	32	24	12		
	1.00	51	47	49	44	34	24	-	52	47	46	43	39	34	14		
	1.50	52	48	50	45	35	24	-	53	48	47	45	42	39	16		
	3.00	53	50	52	48	37	29	-	53	49	50	49	48	48	23		
75/75	.50	45	42	43	39	29	21	-	51	44	41	39	31	24	10		
	1.00	47	43	44	39	30	22	-	51	44	43	41	36	34	12		
	1.50	47	44	45	40	31	22	-	52	45	44	42	40	41	16		
	3.00	48	45	47	42	34	27	-	52	45	45	45	46	48	23		
0/150	—	42	42	45	39	27	21	-	53	45	41	38	27	20	—		
75/0	.02	42	39	40	33	22	20	-	48	39	35	31	19	20	—		
	.50	44	41	41	35	23	20	-	48	41	39	35	29	23	—		
	1.00	44	42	42	37	26	20	-	49	42	41	39	36	34	10		
	1.50	45	43	43	38	27	21	-	49	42	42	40	40	40	15		
	3.00	47	45	46	41	32	24	-	49	43	45	44	46	49	24		
38/38	.50	42	39	40	34	22	20	-	49	41	39	34	28	22	—		
	1.00	42	40	41	35	24	20	-	48	40	39	37	36	36	11		
	1.50	42	41	42	36	26	21	-	49	40	39	38	39	42	17		
	3.00	42	41	42	36	27	24	-	49	41	40	41	43	43	18		
0/75	—	41	40	42	34	22	20	-	48	39	35	31	19	20	—		

- Notes:
1. ΔP_s static pressure difference from inlet to discharge.
 2. ΔP_s is the minimum required to deliver CFM shown the primary damper in open position.
 3. ΔP does not include hot water or electric coils.
 4. Dash (-) indicates NC level less than 10.

NC level are derived from tests conducted in accordance with ARI Standard 880-98 and are calculated in accordance with Appendix E of ARI Standard 885-98 as application data based on the following:

Discharge NC levels are based on -

- a) 5 foot rectangular duct lined with 1" fiberglass insulation.
- b) 6 foot lined flex duct (8" diameter).
- c) Maximum 300 CFM per outlet.
- d) Space effect factor (5000 ft³) at 10 feet from outlet.
- e) End reflection.
- f) Environment adjustment factor.

Radiated NC levels are based on -

- a) Plenum/ceiling effect - mineral fiber tile
- b) Environment adjustment factor.



A Participating Member
in the ARI 880
Certification Program

UNIT SIZE - U2
Inlet Size - 6"

(FAN ON — 100% Primary Air/Mix/100% Secondary Air)

Primary/ Secondary CFM	Primary Air ΔP_s	Discharge Sound							Max. NC	Radiated Sound							Max. NC
		Sound Power db Octave Band								Sound Power db Octave Band							
		2	3	4	5	6	7	2		3	4	5	6	7			
420/0	.23	59	58	58	56	53	48	15	61	56	53	49	39	29	22		
	.50	60	58	59	59	55	49	15	61	56	55	55	42	32	26		
	1.00	61	58	60	59	55	49	15	61	58	57	56	44	37	27		
	1.50	62	59	60	59	56	49	16	63	59	59	57	47	42	28		
	3.00	64	61	61	60	57	50	18	64	60	60	60	52	49	32		
210/210	.50	57	55	57	56	53	48	12	57	51	50	49	39	29	20		
	1.00	57	55	57	56	53	48	12	57	52	51	50	41	35	21		
	1.50	57	56	57	57	54	49	14	58	53	52	50	44	41	21		
	3.00	58	57	58	57	54	49	15	58	54	56	54	50	49	25		
0/420	—	54	54	56	55	52	47	11	56	49	49	48	38	26	19		
300/0	.12	51	50	51	47	41	35	—	53	48	45	42	30	20	13		
	.50	54	52	55	52	44	36	—	55	50	49	48	35	27	19		
	1.00	55	53	55	52	45	36	10	56	52	52	51	40	35	22		
	1.50	55	54	55	53	45	37	11	57	53	54	52	43	41	23		
	3.00	58	56	58	56	49	39	14	59	56	58	56	50	49	27		
150/150	.50	50	48	50	47	41	33	—	51	46	45	43	32	24	14		
	1.00	50	48	51	48	41	34	—	52	47	47	45	37	35	16		
	1.50	51	49	52	49	42	34	—	53	48	49	46	41	39	18		
	3.00	52	50	53	50	42	34	—	53	50	52	50	48	48	23		
0/300	—	48	46	49	46	40	32	—	52	45	44	43	31	20	14		
200/0	.05	47	46	47	43	36	29	—	51	45	42	40	28	20	11		
	.50	49	48	52	47	38	30	—	51	46	45	45	32	24	16		
	1.00	50	49	53	49	39	31	—	52	48	49	47	38	34	18		
	1.50	51	50	55	49	40	31	—	53	49	51	49	42	40	20		
	3.00	54	53	57	53	43	34	11	54	52	55	53	49	48	24		
100/100	.50	46	45	47	43	35	26	—	51	45	43	41	31	24	12		
	1.00	47	46	47	44	36	27	—	51	45	45	42	36	34	13		
	1.50	48	46	48	44	36	27	—	51	46	46	44	40	40	15		
	3.00	48	48	50	45	38	30	—	52	47	49	48	47	48	23		
0/200	—	46	44	47	42	34	24	—	51	44	44	41	30	20	12		

- Notes: 1. ΔP_s static pressure difference from inlet to discharge.
 2. ΔP_s is the minimum required to deliver CFM shown the primary damper in open position.
 3. ΔP does not include hot water or electric coils.
 4. Dash (—) indicates NC level less than 10.

NC level are derived from tests conducted in accordance with ARI Standard 880-98 and are calculated in accordance with Appendix E of ARI Standard 885-98 as application data based on the following:

Discharge NC levels are based on -

- a) 5 foot rectangular duct lined with 1" fiberglass insulation.
- b) 6 foot lined flex duct (8" diameter).
- c) Maximum 300 CFM per outlet.
- d) Space effect factor (5000 ft³) at 10 feet from outlet.
- e) End reflection.
- f) Environment adjustment factor.

Radiated NC levels are based on -

- a) Plenum/ceiling effect - mineral fiber tile
- b) Environment adjustment factor.



A Participating Member
in the ARI 880
Certification Program

UNIT SIZE - U3
Inlet Size - 7"

(FAN ON — 100% Primary Air/Mix/100% Secondary Air)

Primary/ Secondary CFM	Primary Air Δ Ps	Discharge Sound							Radiated Sound								
		Sound Power db Octave Band							Max. NC	Sound Power db Octave Band							Max. NC
		2	3	4	5	6	7	2		3	4	5	6	7			
680/0	.24	68	67	66	66	64	62	26	70	63	59	58	49	40	30		
	.50	70	69	68	67	66	63	28	70	63	60	59	51	41	31		
	1.00	71	69	68	67	66	63	28	71	64	62	61	52	43	33		
	1.50	71	69	67	67	66	63	28	71	65	63	61	53	45	33		
	3.00	72	70	68	68	67	64	29	74	67	64	64	55	51	36		
340/340	.50	67	65	66	65	64	62	26	68	60	57	56	48	39	27		
	1.00	67	66	66	65	64	62	26	68	60	58	57	49	41	28		
	1.50	67	66	66	65	64	62	26	68	61	59	57	50	43	28		
	3.00	67	66	66	65	64	62	26	68	62	61	60	53	50	32		
0/680	—	66	64	65	65	63	62	26	68	59	55	56	48	39	27		
450/0	.11	57	57	59	57	54	50	14	59	53	52	52	40	28	23		
	.50	59	57	60	59	56	51	15	61	55	53	55	42	32	26		
	1.00	60	58	60	60	56	52	16	62	56	56	56	44	37	27		
	1.50	61	59	61	60	57	52	16	63	57	57	57	46	41	28		
	3.00	63	61	62	61	57	52	18	64	59	61	61	52	50	33		
225/225	.50	58	56	59	57	55	51	14	59	52	51	51	40	31	22		
	1.00	58	57	59	57	55	51	15	59	53	53	51	42	37	22		
	1.50	58	57	59	57	55	51	15	60	53	54	53	44	41	24		
	3.00	59	57	59	58	55	51	15	60	55	56	55	50	48	26		
0/450	—	57	55	57	57	54	50	14	60	51	50	50	40	28	21		
300/0	.05	51	50	52	49	44	38	-	54	47	45	46	33	22	17		
	.50	52	51	54	52	46	39	-	55	50	48	49	36	27	20		
	1.00	54	53	55	53	47	40	10	57	51	51	50	39	36	21		
	1.50	54	53	55	53	47	40	10	57	52	54	53	43	41	24		
	3.00	56	55	57	55	48	41	12	58	55	58	57	50	49	28		
150/150	.50	51	50	52	50	45	38	-	55	47	46	46	34	27	17		
	1.00	52	50	52	50	45	38	-	55	48	48	47	38	35	18		
	1.50	52	50	53	51	45	38	-	55	48	49	48	41	39	19		
	3.00	53	51	53	51	45	38	-	57	50	51	51	48	48	23		
0/300	—	50	50	52	50	45	38	-	56	46	45	47	33	21	18		

- Notes: 1. Δ Ps static pressure difference from inlet to discharge.
 2. Δ Ps is the minimum required to deliver CFM shown the primary damper in open position.
 3. Δ P does not include hot water or electric coils.
 4. Dash (-) indicates NC level less than 10.

NC level are derived from tests conducted in accordance with ARI Standard 880-98 and are calculated in accordance with Appendix E of ARI Standard 885-98 as application data based on the following:

Discharge NC levels are based on -

- a) 5 foot rectangular duct lined with 1" fiberglass insulation.
- b) 6 foot lined flex duct (8" diameter).
- c) Maximum 300 CFM per outlet.
- d) Space effect factor (5000 ft³) at 10 feet from outlet.
- e) End reflection.
- f) Environment adjustment factor.

Radiated NC levels are based on -

- a) Plenum/ceiling effect - mineral fiber tile
- b) Environment adjustment factor.



A Participating Member
in the ARI 880
Certification Program

UNIT SIZE - U4
Inlet Size - 8"

(FAN ON — 100% Primary Air/Mix/100% Secondary Air)

Primary/ Secondary CFM	Primary Air ΔP_s	Discharge Sound							Max. NC	Radiated Sound							Max. NC
		Sound Power db Octave Band								Sound Power db Octave Band							
		2	3	4	5	6	7	2		3	4	5	6	7			
1000/0	.27	75	73	72	71	69	69	32	74	67	63	62	54	45	34		
	.50	77	75	73	72	71	70	34	76	70	65	65	56	47	37		
	1.00	77	76	73	72	71	70	35	76	70	65	65	57	48	37		
	1.50	78	76	73	72	71	70	35	77	71	67	66	57	50	38		
	3.00	79	78	74	73	72	71	37	79	73	69	68	60	55	40		
500/500	.50	77	75	73	72	71	70	35	75	67	62	62	54	46	35		
	1.00	77	75	73	72	71	70	35	75	67	62	62	54	47	35		
	1.50	77	75	73	72	71	70	35	76	67	63	62	55	48	36		
	3.00	77	76	73	73	71	70	36	75	68	65	65	57	53	37		
0/1000	—	75	73	71	71	69	69	32	75	65	61	61	54	46	35		
750/0	.15	68	65	65	65	61	60	24	68	60	58	57	46	36	28		
	.50	70	68	67	66	64	62	26	71	63	59	61	50	40	33		
	1.00	70	68	67	67	64	62	26	71	64	61	61	50	43	33		
	1.50	71	68	67	67	64	62	26	71	65	63	63	52	46	35		
	3.00	72	69	68	67	65	62	27	72	67	66	66	56	53	38		
375/375	.50	69	67	66	66	63	62	26	71	60	57	58	49	40	30		
	1.00	70	67	66	66	63	62	26	71	61	58	58	50	42	30		
	1.50	70	67	66	66	63	62	26	71	62	60	59	51	45	31		
	3.00	70	67	67	66	63	62	26	71	63	62	63	54	51	35		
0/750	—	69	66	66	66	64	63	27	72	60	57	57	51	44	31		
500/0	.07	59	58	59	58	53	50	15	63	54	51	51	39	26	22		
	.50	61	60	61	60	56	52	17	65	56	55	55	43	33	26		
	1.00	63	60	61	60	56	52	17	65	58	56	56	45	39	27		
	1.50	63	61	61	61	56	52	18	65	59	59	58	48	44	30		
	3.00	63	62	62	61	56	52	19	66	62	64	63	53	52	35		
250/250	.50	61	59	59	59	55	53	17	65	54	52	52	41	32	23		
	1.00	62	59	59	59	55	53	17	66	55	54	54	44	38	25		
	1.50	62	59	59	59	55	53	17	66	56	55	55	46	43	26		
	3.00	62	60	60	60	55	53	18	66	58	58	59	51	50	31		
0/500	—	60	59	59	59	55	52	16	69	55	52	53	45	35	27		

- Notes: 1. ΔP_s static pressure difference from inlet to discharge.
 2. ΔP_s is the minimum required to deliver CFM shown the primary damper in open position.
 3. ΔP does not include hot water or electric coils.
 4. Dash (—) indicates NC level less than 10.

NC level are derived from tests conducted in accordance with ARI Standard 880-98 and are calculated in accordance with Appendix E of ARI Standard 885-98 as application data based on the following:

Discharge NC levels are based on -

- a) 5 foot rectangular duct lined with 1" fiberglass insulation.
- b) 6 foot lined flex duct (8" diameter).
- c) Maximum 300 CFM per outlet.
- d) Space effect factor (5000 ft³) at 10 feet from outlet.
- e) End reflection.
- f) Environment adjustment factor.

Radiated NC levels are based on -

- a) Plenum/ceiling effect - mineral fiber tile
- b) Environment adjustment factor.



A Participating Member
in the ARI 880
Certification Program

Fan Powered Units

UNIT SIZE - U5
Inlet Size - 10"

(FAN ON — 100% Primary Air/Mix/100% Secondary Air)

Primary/ Secondary CFM	Primary Air Δ Ps	Discharge Sound							Max. NC	Radiated Sound							Max. NC
		Sound Power db Octave Band								Sound Power db Octave Band							
		2	3	4	5	6	7	2		3	4	5	6	7			
1525/0	.24	82	79	77	77	74	74	38	80	73	66	66	59	50	41		
	.50	84	79	77	77	75	74	39	82	74	67	67	60	51	44		
	1.00	84	81	78	78	76	74	41	82	75	69	69	62	53	44		
	1.50	85	81	79	78	77	75	41	83	77	70	70	62	54	45		
	3.00	86	81	79	79	77	75	41	85	79	43	73	64	58	48		
763/763	.50	81	78	76	76	74	73	37	77	71	65	66	59	51	38		
	1.00	81	78	76	76	74	73	37	77	71	66	66	60	51	38		
	1.50	81	78	76	76	74	74	37	77	71	66	67	60	51	39		
	3.00	81	78	77	77	76	75	38	79	72	68	69	61	55	41		
0/1525	—	80	77	75	75	73	72	36	77	70	63	64	58	49	37		
1200/0	.13	78	74	73	72	70	69	33	75	68	61	61	54	46	35		
	.50	78	75	74	73	71	69	34	76	69	63	64	56	47	36		
	1.00	78	75	74	73	71	69	34	78	71	65	65	57	48	39		
	1.50	78	75	74	73	71	69	34	79	72	66	67	58	50	40		
	3.00	81	77	75	74	72	70	36	80	74	70	70	61	56	42		
600/600	.50	78	74	72	72	69	69	34	73	67	61	62	54	46	34		
	1.00	78	74	72	72	69	69	34	73	67	62	63	55	47	35		
	1.50	78	74	73	72	69	69	34	73	67	63	64	55	49	36		
	3.00	78	74	73	73	70	69	34	76	69	65	67	58	53	39		
0/1200	—	78	72	72	72	69	68	31	73	64	60	60	54	45	32		
900/0	.08	70	65	66	65	62	60	24	66	59	56	55	48	38	26		
	.50	71	66	67	66	62	61	25	69	63	59	59	49	40	31		
	1.00	72	68	68	68	64	62	26	73	66	61	61	52	43	33		
	1.50	74	69	69	68	64	62	27	73	67	63	63	54	47	35		
	3.00	76	71	70	69	66	63	29	75	70	67	68	58	54	40		
450/450	.50	72	66	66	66	63	62	26	66	60	57	57	48	39	28		
	1.00	70	66	67	66	63	61	25	67	61	58	58	49	42	30		
	1.50	69	65	67	67	63	61	25	68	62	60	60	51	45	32		
	3.00	71	66	68	67	64	62	26	71	64	61	64	55	51	36		
0/900	—	69	64	66	65	62	61	25	67	58	55	56	48	38	27		

- Notes:
1. ΔPs static pressure difference from inlet to discharge.
 2. ΔPs is the minimum required to deliver CFM shown the primary damper in open position.
 3. ΔP does not include hot water or electric coils.
 4. Dash (-) indicates NC level less than 10.

NC level are derived from tests conducted in accordance with ARI Standard 880-98 and are calculated in accordance with Appendix E of ARI Standard 885-98 as application data based on the following:

Discharge NC levels are based on -

- a) 5 foot rectangular duct lined with 1" fiberglass insulation.
- b) 6 foot lined flex duct (8" diameter).
- c) Maximum 300 CFM per outlet.
- d) Space effect factor (5000 ft³) at 10 feet from outlet.
- e) End reflection.
- f) Environment adjustment factor.

Radiated NC levels are based on -

- a) Plenum/ceiling effect - mineral fiber tile
- b) Environment adjustment factor.



A Participating Member
in the ARI 880
Certification Program

FAN CURVES CFM vs EXTERNAL STATIC PRESSURE

FAN SIZE A - UNDERFLOOR AC U1
1/6 H.P. Motor

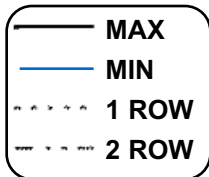
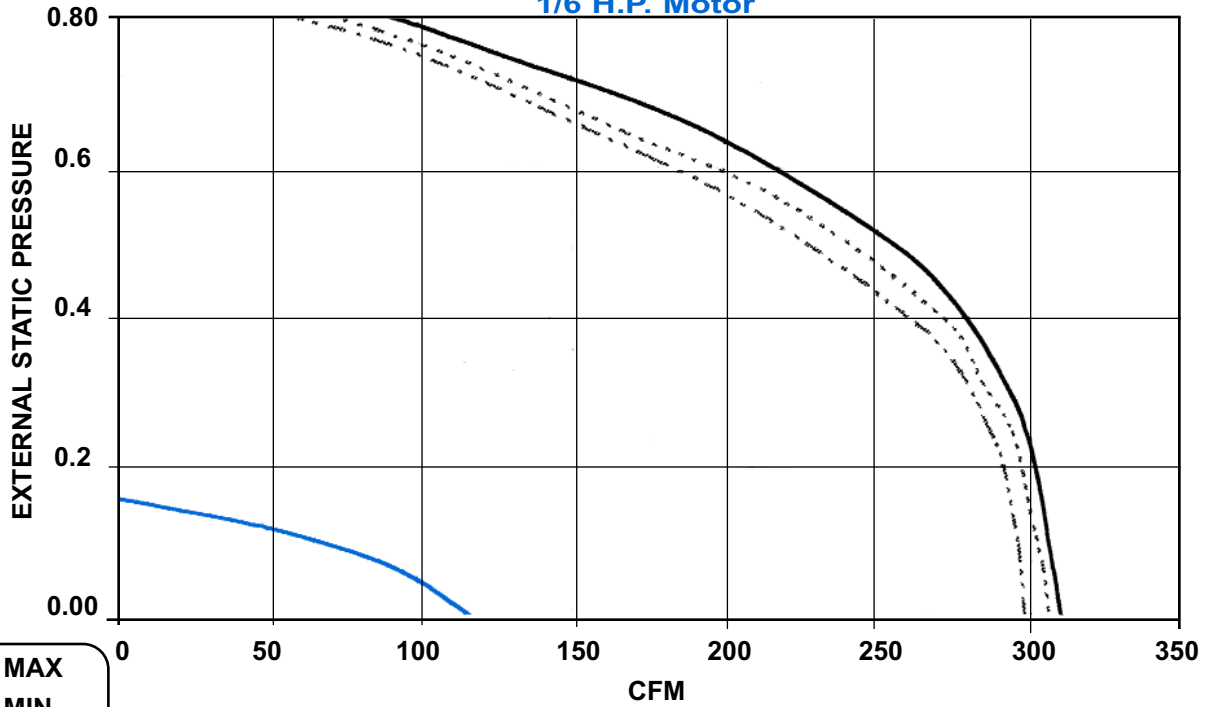

FAN SIZE B - UNDERFLOOR AC U2
1/6 H.P. Motor

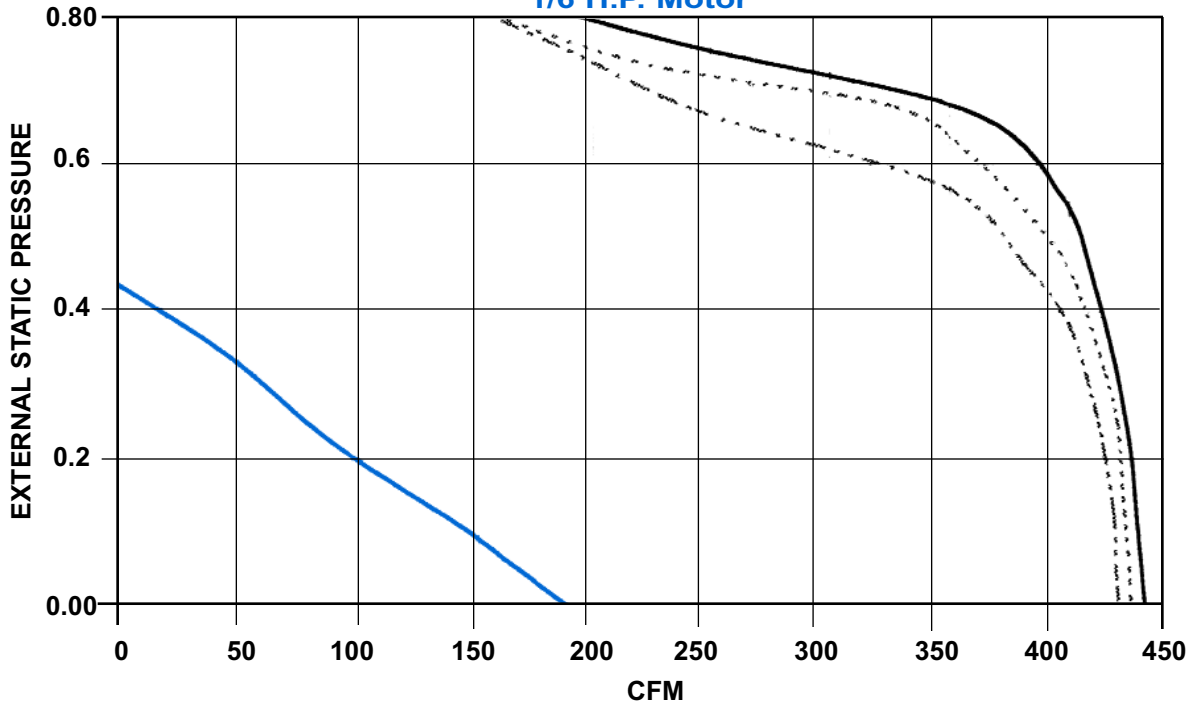

- NOTES:
1. External Static Pressure (ESP) consists of down stream ductwork, coils, flex, duct, etc.
 2. Pressure drop due to heating coils are treated as external static pressure.
 3. For proper operation, the downstream ESP must be at least 0.20" W. G.

FAN CURVES CFM vs EXTERNAL STATIC PRESSURE

FAN SIZE C - UNDERFLOOR AC U3
1/6 H.P. Motor

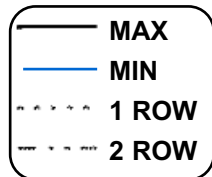
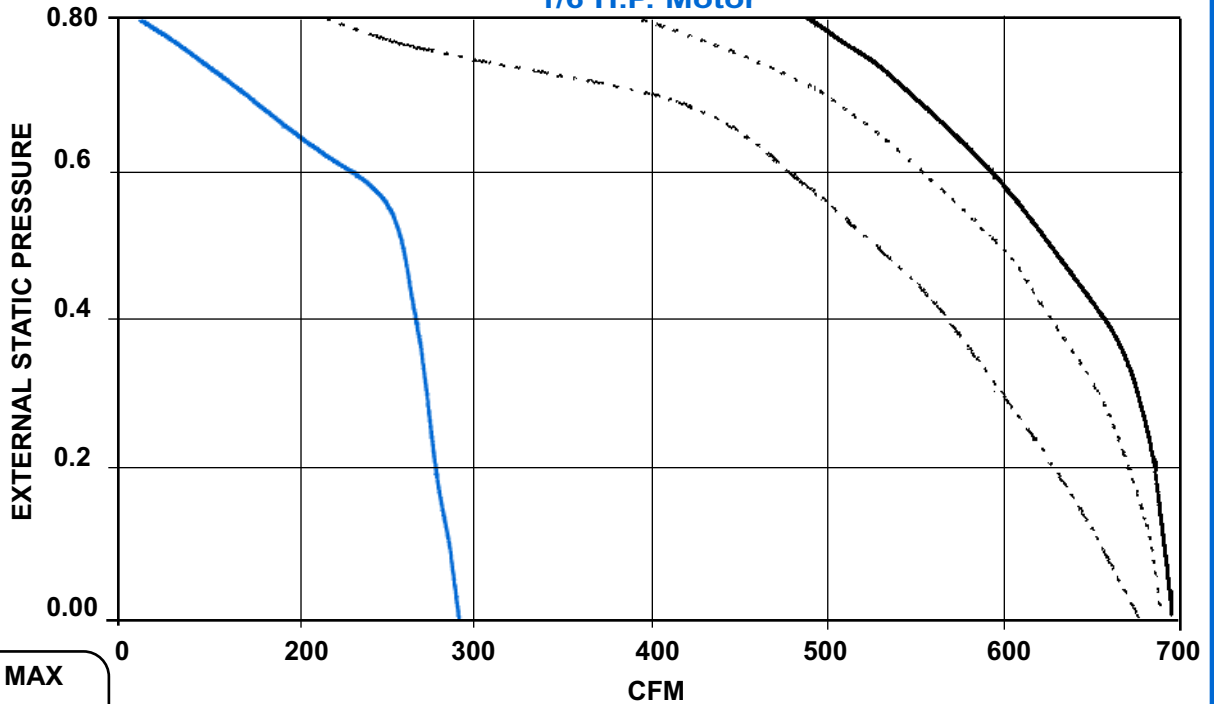

FAN SIZE D - UNDERFLOOR AC U4
1/4 H.P. Motor

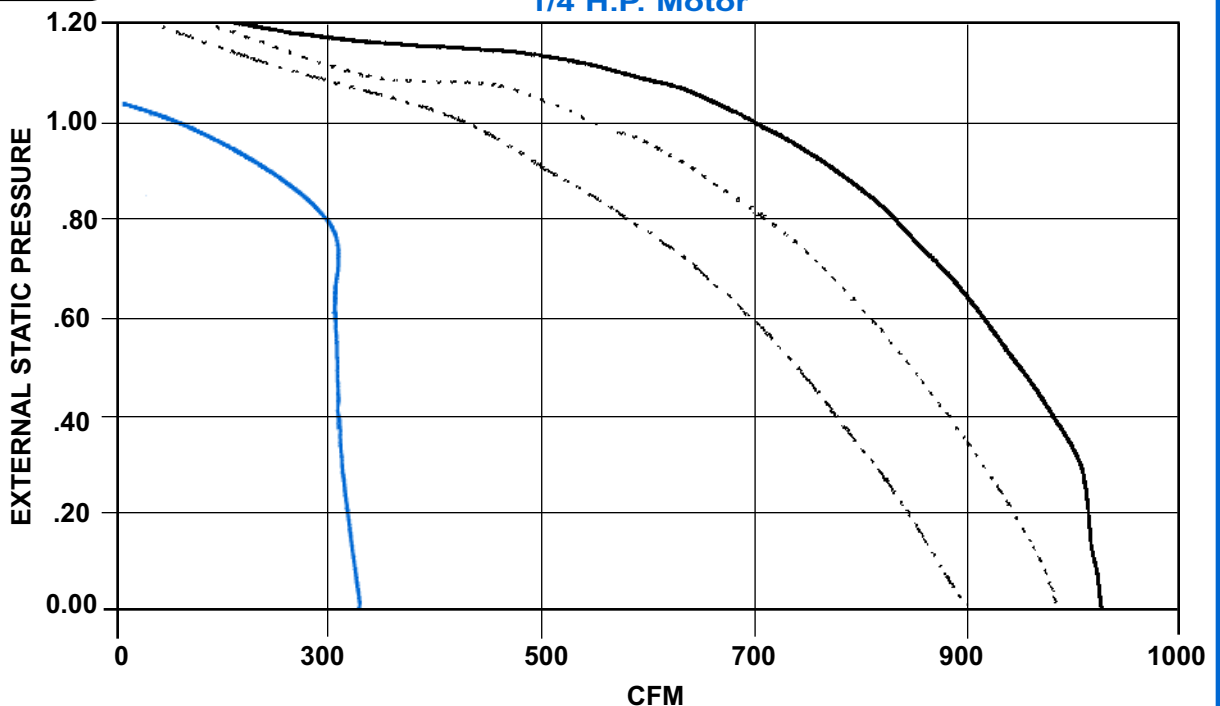

- NOTES:
1. External Static Pressure (ESP) consists of down stream ductwork, coils, flex, duct, etc.
 2. Pressure drop due to heating coils are treated as external static pressure.
 3. For proper operation, the downstream ESP must be at least 0.20" W. G.

FAN CURVES CFM vs EXTERNAL STATIC PRESSURE

FAN SIZE E - UNDERFLOOR AC U5
1/4 H.P. Motor

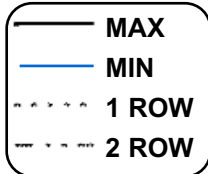
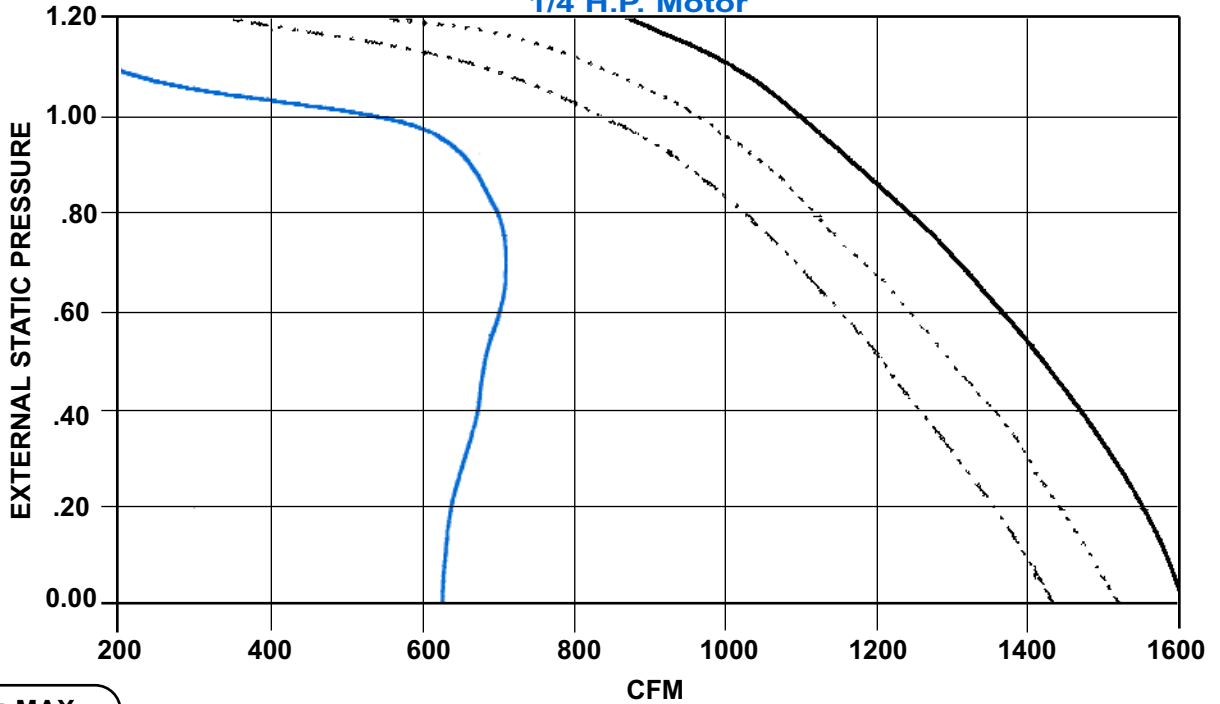

- NOTES:
1. External Static Pressure (ESP) consists of down stream ductwork, coils, flex, duct, etc.
 2. Pressure drop due to heating coils are treated as external static pressure.
 3. For proper operation, the downstream ESP must be at least 0.20" W. G.

Fan Powered Units

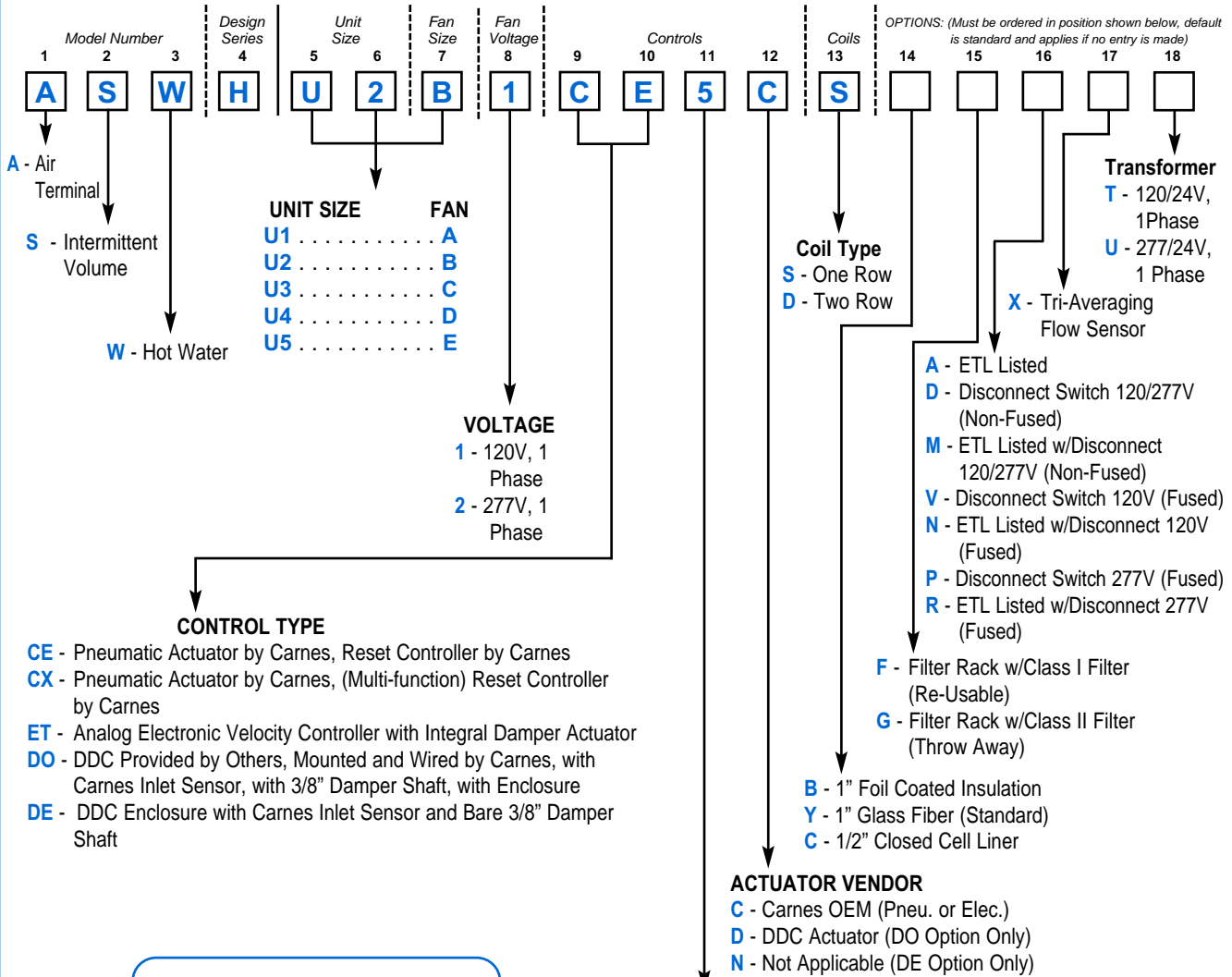

NOTE: Hand of controls is determined by facing the averaging flow sensor (inlet of the unit) with the supply air hitting the back of your head.

CONTROLS AND DAMPER ARRANGEMENT

- *1 - Normally Open - Right Hand Controls (Electronic/DO, DE, ET) (All Pneumatic Control Types for Reverse Acting Thermostat)
- 3 - Normally Closed - Right Hand Controls (All Pneumatic Control Types for Direct Acting Thermostat)
- 5 - Normally Open - Right Hand Controls (All Pneumatic Control Types for Direct Acting Thermostat)
- 7 - Normally Closed - Right Hand Controls (All Pneumatic Control Types for Reverse Acting Thermostat)

▼ Electronic Thermostat

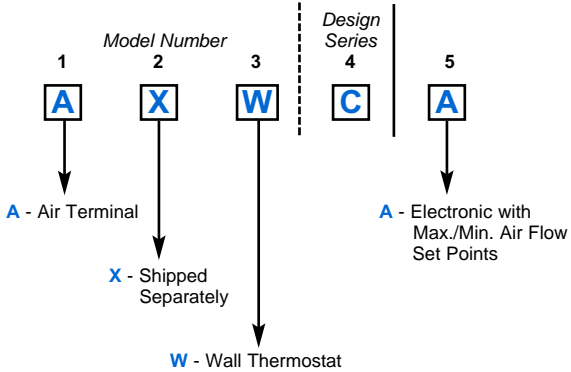

A Carnes Electronic Thermostat **must be ordered** with the ET Electronic Control Option.

* Electronic and DDC Units **DO NOT** fail open. '1' or '2' is used for Right or Left Hand Only. Electronic Units are shipped with the Damper in the Open Position.

Model ACWH

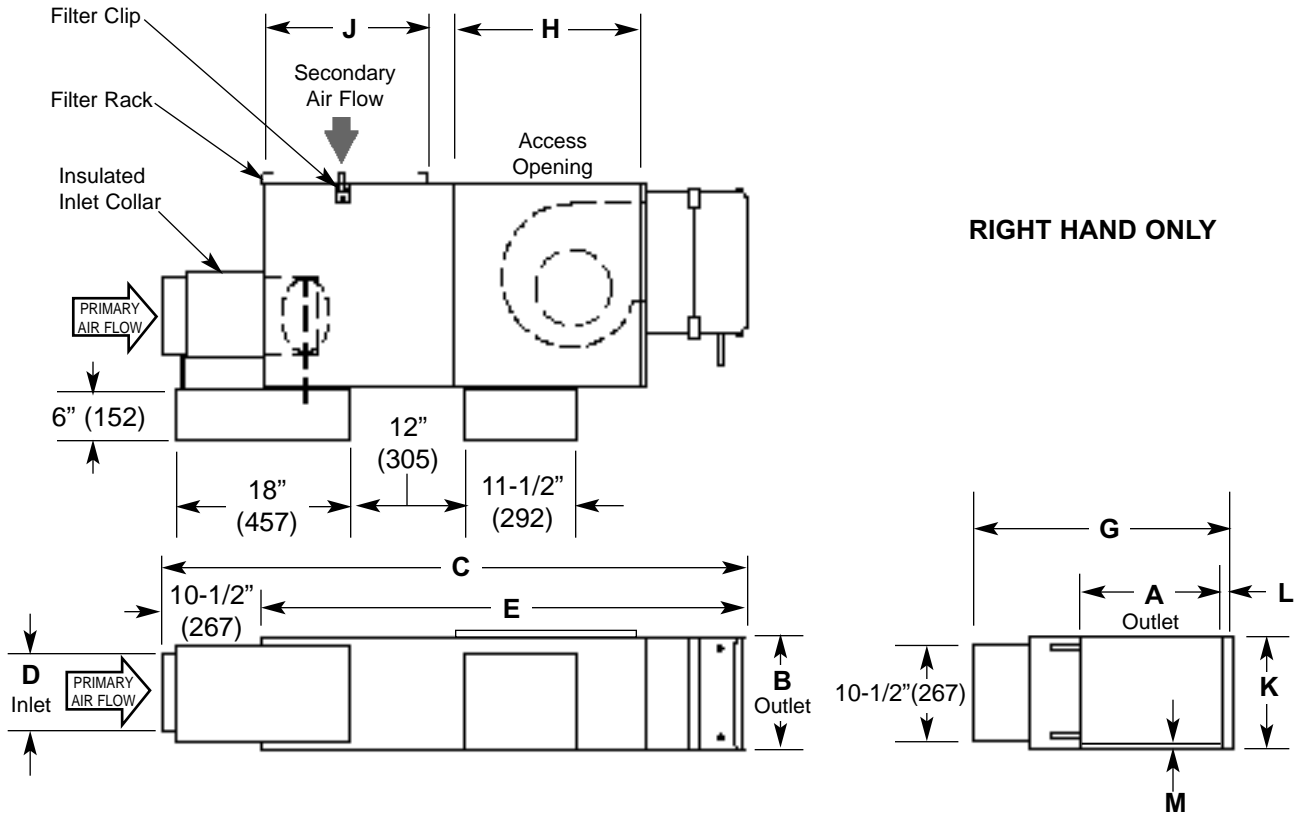

RIGHT HAND ONLY

Fan Powered Units

DIMENSIONS LISTED IN INCHES (Millimeters)																			
Unit Size	Fan Size	Inlet Size	Primary CFM (L/s)	Secondary CFM (L/s) @ .25 E.S.P.	Fan H.P.	Outlet				Inlet		E 1-Row	E 2-Row	G	H	J	K	L	M
						A	B	C 1-Row	C 2-Row	D									
U1	A	05	350 (165)	290 (137)	1/6					4-7/8 (124)									
U2	B	06	500 (236)	420 (198)	1/6	12 (305)	10 (254)	56-1/2 (1435)	58 (1473)	5-7/8 (149)	46-1/8 (1172)	47-1/2 (1207)	27 (685)	19-1/4 (489)	16 (406)	10-1/2 (267)	1/2 (13)	1/2 (13)	
U3	C	07	700 (330)	680 (321)	1/6					6-7/8 (175)									
U4	D	08	1000 (472)	1000 (472)	1/4					7-7/8 (200)							1/2 (13)		
U5	E	10	1500 (708)	1525 (720)	1/2	14 (356)	12-1/2 (318)	56-1/2 (1435)	58 (1473)	9-7/8 (251)	46-1/8 (1172)	47-1/2 (1207)	27 (685)	19-1/4 (489)	17 (432)	12-1/2 (318)	--	--	

NOTE: Outlet is designed for slip and drive duct connection.