

**CARNES<sup>®</sup>**

### RECOMMENDED SPECIFICATIONS

Provide open coil electric duct heaters of the size, capacity and performance shown on the job schedule. All duct heaters shall be tested and certified to **UL** STD 1996 UL File number E245517. Heating elements shall be open coil type, 80% nickel 20% chromium, type A resistance wire. Other alloys are not acceptable. Coils shall be supported by steatite ceramic bushings securely fastened to the element support brackets. The duct heater frame, control enclosure and element support brackets shall be of 20 gauge (minimum) galvanized steel. The controls enclosure shall be **NEMA-1** construction with standard door interlocking disconnect switch. The electric heater frame will have flanged or slip-in duct connection. All heaters shall be furnished with a disc type, primary automatic reset thermal cut-off. A secondary manual reset thermal cut-off will also be provided. All heaters will have an integral air flow switch or a fan interlock relay (fan terminal units only). The electric supply wiring shall have insulation rating of 221°F (105°C). Terminal blocks and ground lugs will be furnished on all heaters for field wiring. A line voltage to 24 volt, class II transformer shall be provided and mounted inside the control enclosure. All heaters shall have a disconnecting magnetic contactor(s) with a 24-volt holding coil as standard.

**PRODUCT FEATURES AND CONSTRUCTION**

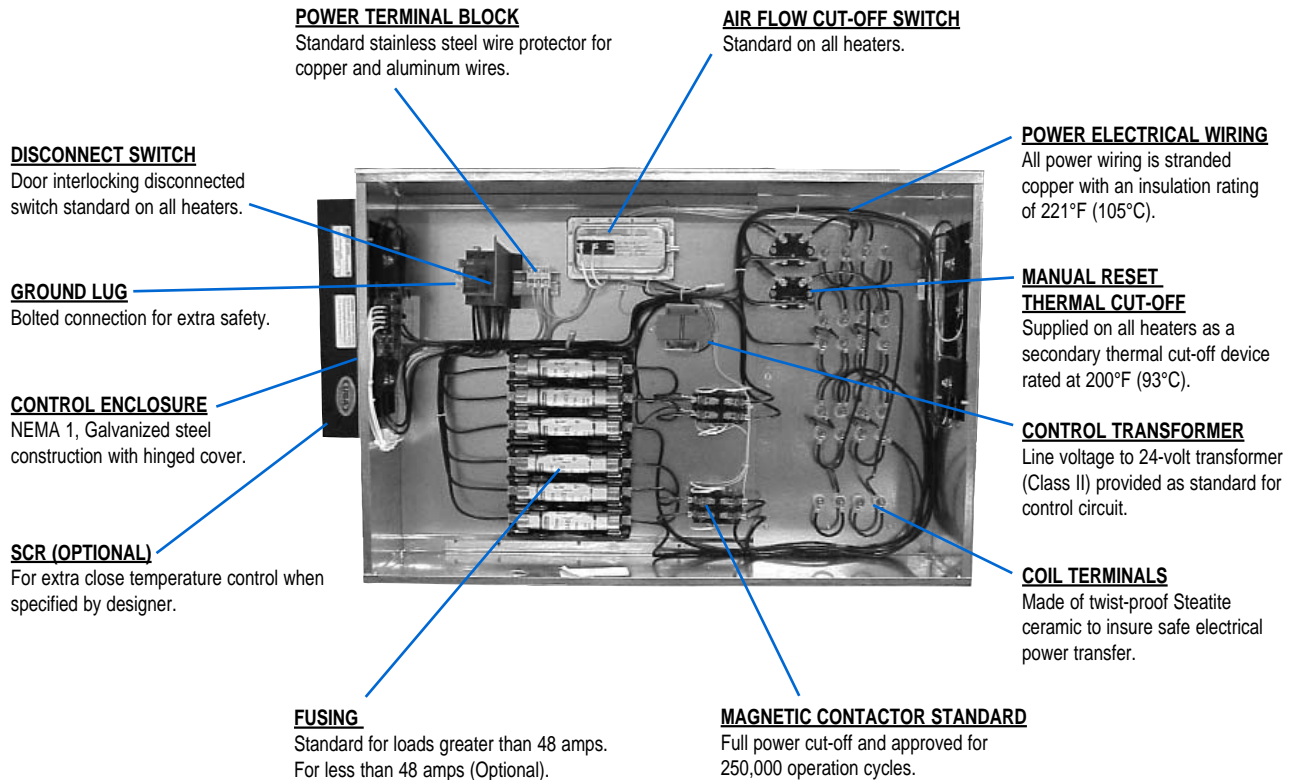

**POWER TERMINAL BLOCK**  
Standard stainless steel wire protector for copper and aluminum wires.

**AIR FLOW CUT-OFF SWITCH**  
Standard on all heaters.

**DISCONNECT SWITCH**  
Door interlocking disconnected switch standard on all heaters.

**POWER ELECTRICAL WIRING**  
All power wiring is stranded copper with an insulation rating of 221°F (105°C).

**GROUND LUG**  
Bolted connection for extra safety.

**MANUAL RESET THERMAL CUT-OFF**  
Supplied on all heaters as a secondary thermal cut-off device rated at 200°F (93°C).

**CONTROL ENCLOSURE**  
NEMA 1, Galvanized steel construction with hinged cover.

**CONTROL TRANSFORMER**  
Line voltage to 24-volt transformer (Class II) provided as standard for control circuit.

**SCR (OPTIONAL)**  
For extra close temperature control when specified by designer.

**COIL TERMINALS**  
Made of twist-proof Steatite ceramic to insure safe electrical power transfer.

**FUSING**  
Standard for loads greater than 48 amps. For less than 48 amps (Optional).

**MAGNETIC CONTACTOR STANDARD**  
Full power cut-off and approved for 250,000 operation cycles.

**CERAMIC ELEMENT SUPPORTS**  
Steatite ceramic support bushings designed for high temperature applications (not shown).

**HEATING COIL ELEMENT**  
Made of nickel-chrome resistance alloy (80% NI - 20% CR) for durability and long life (not shown).

**AUTOMATIC RESET THERMAL CUT-OFF**  
Primary thermal cut-off supplied on all heaters, cut-off temperature is 145°F (62°C) (not shown).

\*Internal components may vary.

## GENERAL INFORMATION

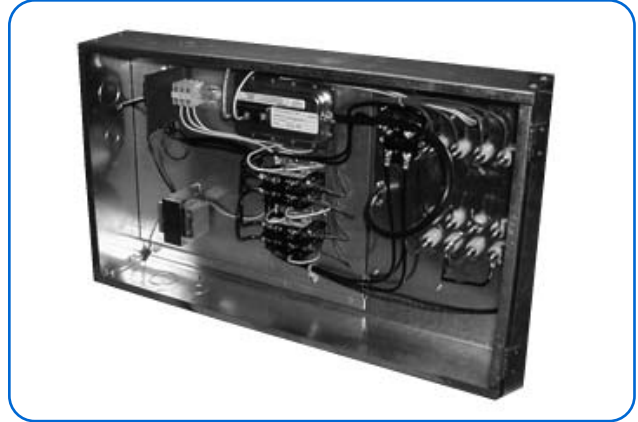
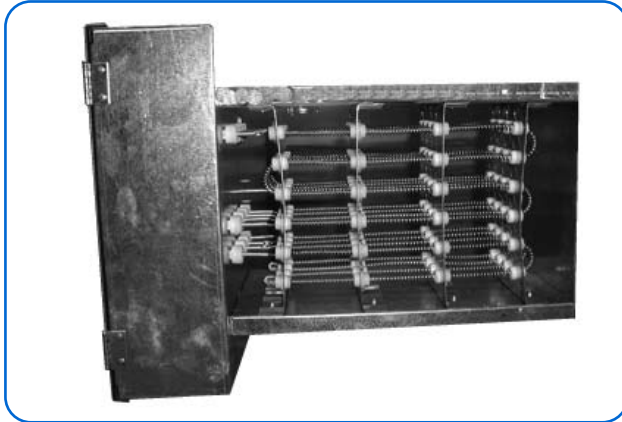

Carnes electric duct heaters are designed for use in commercial and industrial HVAC duct systems. Our open coil heater design comes from closely evaluating the needs of design engineers, contractors and end users. Carnes duct heaters may be used to heat an entire building or as a supplemental heating source. Our duct heaters are tested as an integral component of fan powered and throttling type air terminal units for VAV systems. However, this heater design may be used as a stand-alone device in HVAC systems.

### ***ETL LISTED AND APPROVED TO UL STANDARDS***

Carnes electric duct heaters have been tested and certified by Underwriters Laboratories to **UL** STD 1996 **UL** File Number E245517.

### ***PRODUCT QUALITY***

Our electric heater components have been selected following stringent selection criteria to ensure long, safe and reliable operation.

- **Electrical Components**

All electrical components are approved to **UL** standards.

- **Heater Elements**

All heater elements are constructed from a nickel-chrome alloy without joints except at connecting studs (80% NI - 20% CR, Grade A wire @ 45 watts/in<sup>2</sup>).

- **Power Wiring**

Electric power wire rating has been standardized to 221°F (105°C). This high-grade wire is used on all electric heaters.

- **Magnetic Contactors**

All duct heaters are provided with magnetic contactors as standard. These devices provide full power cut-off and are rated for 250,000 duty cycles.

- **Construction**

The controls enclosure and element frame are built from 20 gauge (minimum) galvanized steel. Our standard **NEMA-1** control enclosure exceeds **UL** requirements.

## STANDARD SAFETY DEVICES

- **Air Flow Switch**

An air flow cut-off switch is provided on each heater to ensure air flow across the heating elements. Switch makes at .07" W.C. (fan interlock relay used on fan terminals).

- **Primary Thermal Cut-Off**

An automatic reset thermal cut-off is standard and will stop the unit when the high limit temperature is reached. The heater will re-start automatically when the temperature has dropped below the high limit of 145°F (62°C).

- **Secondary Thermal Cut-Off**

A manual reset thermal cut-off is also standard and will stop the unit when the high temperature limit is reached. The heater must be carefully inspected prior to manual resetting of this thermal cut-off (cut-off temperature 200°F (93°C)).

- **Disconnect Switch**

A door interlocking disconnect switch is used to disconnect the electric supply from the outside of the controls enclosure prior to service or inspection. This safety feature is often specified and is available with or without power fusing.

- **Fan Interlock Relay**

A fan interlock relay is used on electric duct heaters for fan terminal units. This device ensures that the fan is energized prior to the electric heater.

- **Steatite Element Supports**

Heater element support bushings are made of a Steatite ceramic material designed for high temperature industrial applications. This material has high dielectric strength and resistance to thermal and mechanical shocks.

- **Steatite Coil Terminals**

Coil terminals are made of a Steatite ceramic material. These twist-proof insulators provide safe electrical transfer from the control panel to the elements.

- **Transformer Standard**

A line voltage to 24-volt class II transformer with internal overcurrent protection is provided with each electric duct heater. Primary voltages of 120-600 volts are available.

- **Terminal Block**

The power wiring terminal block is supplied with a stainless steel wire protector for copper or aluminum wires. A bolted ground lug is provided for added safety.

### **POWER FUSING (Optional)**

- **UL** and **NEC** codes require supply fusing for all electric duct heaters that draw more than 48 amps. Heaters over 48 amps will be sub-divided into circuits not exceeding 48 amps and will be fused accordingly. Power fusing is available for units that draw less than 48 amps when specified.

### **SCR CONTROLLER (Optional)**

- Silicone controlled rectifiers (SCR) provide very accurate, heat control and silent duct heater operation. Heat output is precisely controlled from 0 to 100% when used with a modulating type room thermostat. Typical SCR input signals are 0-5 Vdc, 0-10 Vdc, 4-20 mA and 0-135 ohms.

**ENGINEERING AND PERFORMANCE DATA**

Since an electric duct heater has a constant BTU/H output as long as the heater is energized, a minimum air velocity must be maintained through the heater. Proper air flow will prevent over-temperature causing nuisance tripping and will maintain element life expectancy. The velocity of air flow in the duct is determined by the formula:

**VELOCITY = CFM ÷ DUCT AREA**

In addition, the minimum air flow velocity is indicated on each heater.

*The minimum air velocity through the electric heater based on the duct area (ft<sup>2</sup>) is determined by:*

$$V_{fpm} = \frac{KW \times 3160}{Area \times (T_2 - T_1)}$$

The electric heaters are suitable for zero clearance between the heater and combustible material. Electric heaters are shipped uninsulated with slip-in or flange connections for easy installation into duct work.

The inlet and outlet air temperature should be selected within the temperature limitations of the heater. The maximum discharge air temperature is 120°F. The electric heater is an open coil design and should be mounted in a horizontal position maintaining proper air flow direction.

- Vfpm** = Minimum air velocity
- Area** = Sq. Ft. of duct area
- KW** = Kilowatt of Heater
- T<sub>2</sub>** = Discharge air (120°F Max.)
- T<sub>1</sub>** = Entering Air Temperature

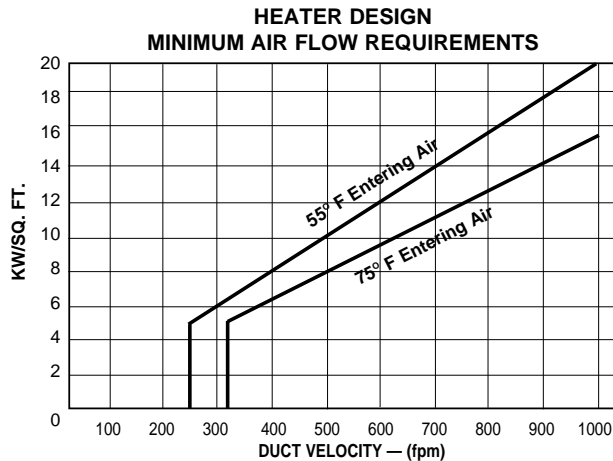

1. Conversion: **1 KW** = **3413 Btu/h**
2. Load Requirement: **KW** =  $\frac{\text{Cubic Feet Per Min.} \times \text{Temperature Rise}}{3160}$
3. \*Temperature Rise: **TR** =  $\frac{\text{KW} \times 3160}{\text{Cubic Feet per Min.}}$
4. Ohm's Law: **Watts** =  $\frac{(\text{Volts})^2}{\text{Resistance}} = \text{Volts} \times \text{Amps}$
5. Line Current, 1 Phase: **Amps** =  $\frac{\text{Watts}}{\text{Volts}}$
6. Line Current, 3 Phase: **Amps** =  $\frac{\text{Watts}}{1.73 \times \text{Volts}}$
7. Pressure Drop: **Inches H<sub>2</sub>O** =  $\frac{\text{KW/ft}^2}{760} \times \left[ \frac{\text{Velocity in FPM}}{500} \right]^2$
8. Maximum Discharge Air Temperature = **120°F**

*\* Maximum heater discharge temperature should not exceed 120°F .*

**Max. and Min. Allowable Electric Heater KW for Single Duct Terminal Units**

*1 Phase Line Voltage Heaters*

AVED SIZE		MIN. KW	05/06	07/08	10	12	14	16	18/24
COIL CODE			A	B	F	H	L	M	T
120 VOLT 1 PHASE	1 STEP	.5	5.6	5.6	5.6	5.6	5.6	5.6	5.6
	2 STEPS	.8	5.6	5.6	5.6	5.6	5.6	5.6	5.6
	3 STEPS	1.3	5.6	5.6	5.6	5.6	5.6	5.6	5.6
MAXIMUM HEATER KW									
208 VOLT 1 PHASE	1 STEP	.8	6.1	8.1	9.8	9.8	9.8	9.8	9.8
	2 STEPS	1.3	6.1	8.1	9.8	9.8	9.8	9.8	9.8
	3 STEPS	2.0	6.1	8.1	9.8	9.8	9.8	9.8	9.8
MAXIMUM HEATER KW									
240 VOLT 1 PHASE	1 STEP	.8	6.1	8.1	11.5	11.5	11.5	11.5	11.5
	2 STEPS	1.5	6.1	8.1	11.5	11.5	11.5	11.5	11.5
	3 STEPS	2.4	6.1	8.1	11.5	11.5	11.5	11.5	11.5
MAXIMUM HEATER KW									
277 VOLT 1 PHASE	1 STEP	.9	6.1	8.1	11.8	12.9	12.9	12.9	12.9
	2 STEPS	1.8	6.1	8.1	11.8	12.9	12.9	12.9	12.9
	3 STEPS	2.7	6.1	8.1	11.8	12.9	12.9	12.9	12.9
MAXIMUM HEATER KW									
347 VOLT 1 PHASE	1 STEP	1.1	6.1	8.1	11.8	16.2	16.6	16.6	16.6
	2 STEPS	2.2	6.1	8.1	11.8	16.2	16.6	16.6	16.6
	3 STEPS	3.3	NA	8.1	11.8	16.2	16.6	16.6	16.6
MAXIMUM HEATER KW									
480 VOLT 1 PHASE	1 STEP	1.5	6.1	8.1	11.8	16.2	23.0	23.0	23.0
	2 STEPS	3.0	NA	8.1	11.8	16.2	23.0	23.0	23.0
	3 STEPS	4.5	NA	8.1	11.8	16.2	23.0	23.0	23.0
MAXIMUM HEATER KW									
600 VOLT 1 PHASE	1 STEP	1.8	6.1	8.1	11.8	16.2	23.7	28.4	28.8
	2 STEPS	3.7	6.1	8.1	11.8	16.2	23.7	28.4	28.8
	3 STEPS	5.6	6.1	8.1	11.8	16.2	23.7	28.4	28.8
MAXIMUM HEATER KW									

*3 Phase Line Voltage Heaters*

AVED SIZE		MIN. KW	05/06	07/08	10	12	14	16	18/24
COIL CODE			A	B	F	H	L	M	T
208 VOLT 3 PHASE	1 STEP	1.3	6.1	8.1	11.8	16.2	17.2	17.2	17.2
	2 STEPS	2.4	N/A	8.1	11.8	16.2	17.2	17.2	17.2
	3 STEPS	3.5	N/A	N/A	11.8	16.2	17.2	17.2	17.2
MAXIMUM HEATER KW									
240 VOLT 3 PHASE	1 STEP	1.3	6.1	8.1	11.8	16.2	19.9	19.9	19.9
	2 STEPS	2.6	N/A	8.1	11.8	16.2	19.9	19.9	19.9
	3 STEPS	4.0	N/A	N/A	11.8	16.2	19.9	19.9	19.9
MAXIMUM HEATER KW									
480 VOLT 3 PHASE	1 STEP	2.7	6.1	8.1	11.8	16.2	23.7	28.4	37.9
	2 STEPS	5.4	N/A	8.1	11.8	16.2	23.7	28.4	37.9
	3 STEPS	8.1	N/A	N/A	NA	16.2	23.7	28.4	37.9
MAXIMUM HEATER KW									
600 VOLT 3 PHASE	1 STEP	3.2	6.1	8.1	11.8	16.2	23.7	28.4	37.9
	2 STEPS	6.5	N/A	8.1	11.8	16.2	23.7	28.4	37.9
	3 STEPS	9.7	N/A	N/A	11.8	16.2	23.7	28.4	37.9
MAXIMUM HEATER KW									

**Maximum and Minimum Allowable Electric Heater KW for Models ASE and ACE Fan Terminal Units**

ACEJ, ACEH, ASEH FAN SIZE			--	--	--	A, B, C, D	E, F**	ASEH (14/16 E, F) & ACEJ (G)	H, J	U1/L1 - U4/L4	U5/ L5 - L6
ACEQ FAN SIZE			A, B, C	D	E, F	--	--	--	--	--	--
COIL CODE			C	E	J	D	J	N	R	G	K
VOLTAGE/PHASE		Min. KW PER STEP	MAXIMUM HEATER KW								
HEATER	FAN										
120/1	120/1	.5	5.5	5.1	4.9	5.5	4.9	4.6	3.3	5.7	5.7
277/1	277/1	.9	9.5	11.9	12.5	13.0	12.5	11.6	11.6	8.1	11.8
208/3	120/1	1.3	9.5	11.9	14.8	13.2	14.8	14.0	10.0	8.1	11.8
480/3	277/1	2.7	9.5	11.9	16.3	13.2	16.3	34.4	33.2	8.1	11.8

\*\* Not for AS 14/16 fan sizes E,F.

- NOTES:**
1. Maximum heater discharge temperature should not exceed 120°F.
  2. Discharge temperature = [(KW x 3160)/CFM] + entering air temperature (EAT).
  3. Contact factory for heater/fan combinations not listed.

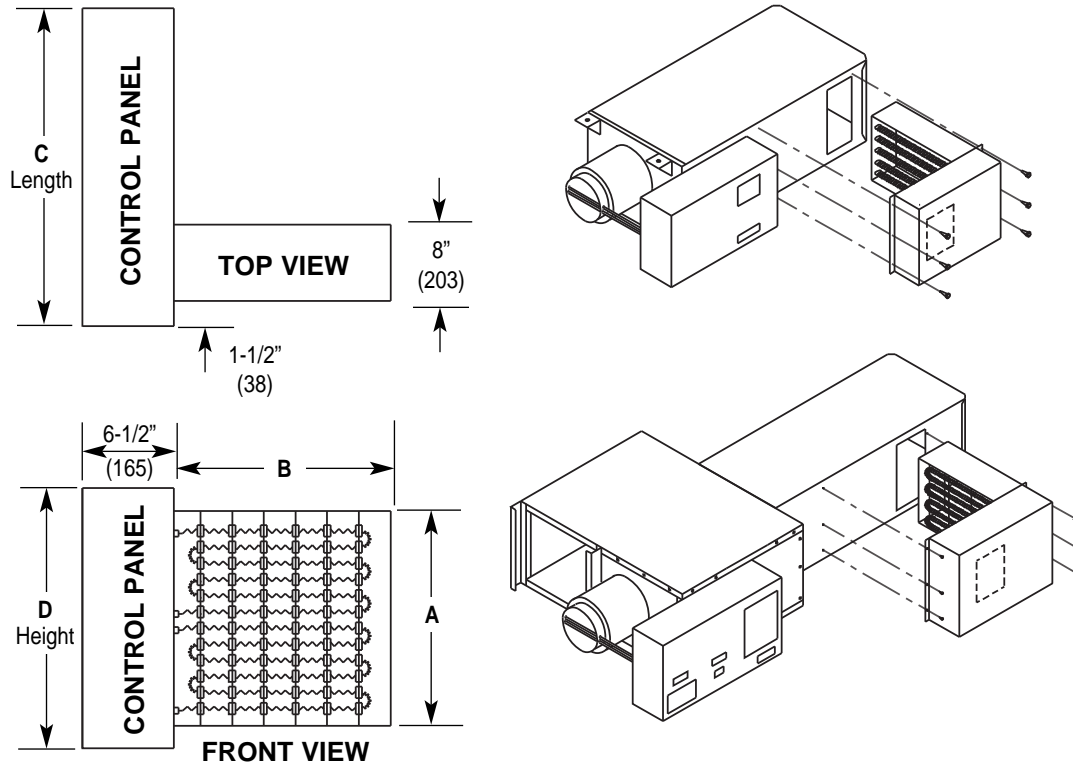

Dimensions Listed in Inches (Millimeters)						
Coil Size Code	VAV Discharge Size		Heater Size		Control Panel	
	Height	Width	A	B	C	D
<b>A</b>	8 (203)	12 (305)	5-11/16 (144)	11-5/8 (295)	21-1/2 (546)	12 (305)
<b>B</b>	10 (254)	12 (305)	8-11/16 (221)	11-5/8 (295)	21-1/2 (546)	12 (305)
<b>C</b>	10 (254)	14 (356)	8-11/16 (221)	13-5/8 (346)	21-1/2 (546)	14 (356)
<b>D</b>	14 (356)	14 (356)	9-11/16 (246)	13-5/8 (346)	21-1/2 (546)	14 (356)
<b>E</b>	12-1/2 (318)	14 (356)	10-5/8 (270)	13-5/8 (346)	21-1/2 (546)	14 (356)
<b>F</b>	12-1/2 (318)	14 (356)	10-5/8 (270)	13-5/8 (346)	21-1/2 (546)	12 (305)
<b>G</b>	10-1/2 (267)	12 (305)	8-11/16 (221)	11-5/8 (295)	20 (508)	10-1/2 (267)
<b>H</b>	15 (381)	16 (406)	13-5/8 (346)	15-9/16 (395)	21-1/2 (546)	16 (406)
<b>J</b>	17-1/2 (445)	16 (406)	13-5/8 (346)	15-9/16 (395)	21-1/2 (546)	16 (406)
<b>K</b>	12-1/2 (318)	14 (356)	10-5/8 (270)	13-5/8 (346)	20 (508)	12 (305)
<b>L</b>	17-1/2 (445)	20 (508)	15-5/8 (397)	19-1/2 (495)	21-1/2 (546)	18 (457)
<b>M</b>	18 (457)	24 (610)	15-5/8 (397)	23-7/16 (595)	21-1/2 (546)	18 (457)
<b>N</b>	17-1/2 (445)	24 (610)	13-1/2 (343)	23-7/16 (595)	21-1/2 (546)	18 (457)
<b>R</b>	17-1/2 (445)	42 (1067)	13-5/8 (346)	41-5/16 (1049)	21-1/2 (546)	16 (406)
<b>S</b>	17-1/2 (445)	32 (813)	13-5/8 (346)	31-5/16 (795)	21-1/2 (546)	16 (406)
<b>T</b>	17-1/2 (445)	32 (813)	15-5/8 (397)	31-5/16 (795)	21-1/2 (546)	18 (457)
<b>Y</b>	20 (508)	24 (610)	18-1/2 (470)	23-7/16 (595)	21-1/2 (546)	22 (559)

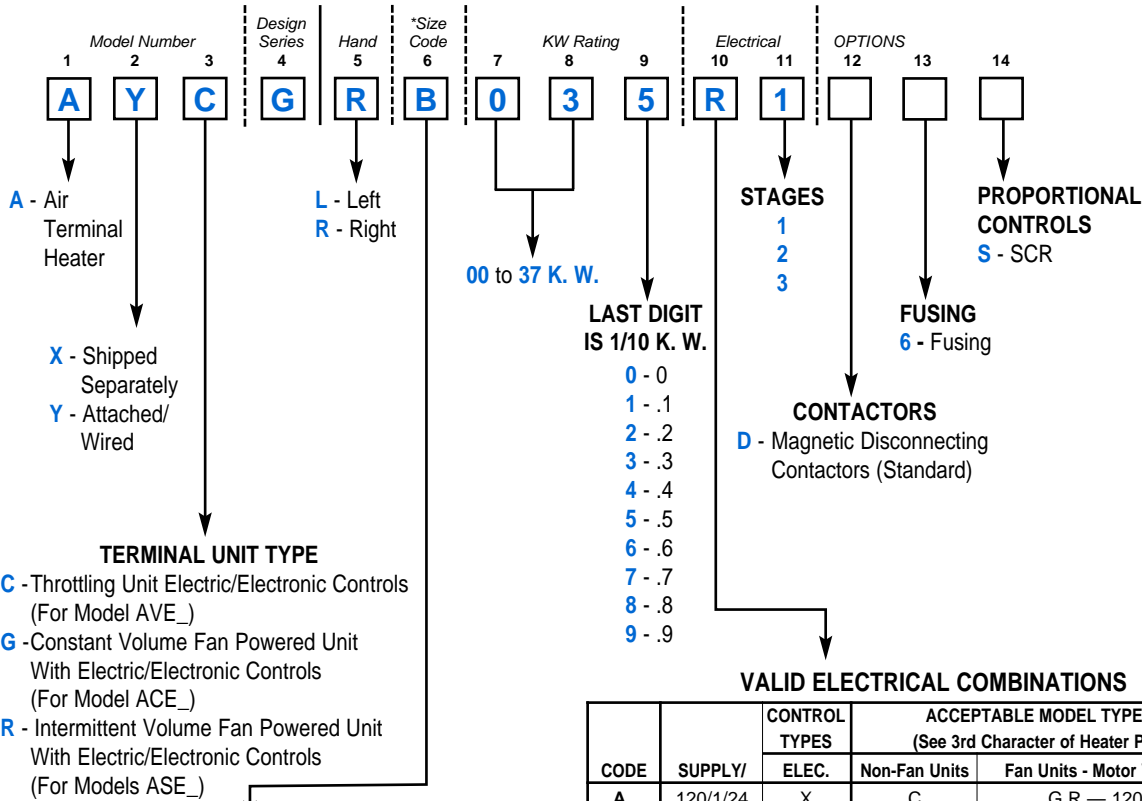

**\* COIL SIZE CODE SELECTION**

COIL SIZE CODE	MODEL/SIZE		MODEL/FAN SIZE	
	AVE	Q SERIES	H & J SERIES	
A	05/06	—	—	—
B	07/08	—	—	—
F	10	—	—	—
H	12	—	—	—
L	14	—	—	—
M	16	—	—	—
T	18/24	—	—	—
Y	—	—	—	—
C	—	A,B,C	—	—
D	—	—	A,B,C,D	—
E	—	D	—	—
G	—	—	U1/L1 - U4/L4	—
K	—	—	U5/L5 - L6	—
J	—	E,F	E,F**	—
N	—	—	AS14-16 E,F / AC G	—
R	—	—	H,J	—

\*\* Not for AS 14/16 fan sizes E,F.

**VALID ELECTRICAL COMBINATIONS**

CODE	SUPPLY/	CONTROL TYPES		ACCEPTABLE MODEL TYPES (See 3rd Character of Heater PID)	
		ELEC.	Non-Fan Units	Fan Units - Motor Voltage	
A	120/1/24	X	C	G,R — 120V	
C	208/1/24	X	C		
E	240/1/24	X	C		
G	277/1/24	X	C	G,R — 277V	
J	480/1/24	X	C		
K*	208/3/24	X	C	G,R — 120V	
N	240/3/24	X	C		
R*	480/3/24	X	C	G,R — 277V	

\* Requires 4-wire system.

**NOTES:**

1. For pneumatically controlled electric heaters contact factory.
2. Maximum and minimum KW must be within range.
3. Right and left hand of heater (space 5) must be ordered the same as the corresponding terminal unit.
4. UL and NEC codes require supply line fusing on all heaters that draw 48 amps or more.
5. Low voltage transformers, air flow switch, primary and secondary thermal cut-outs and door interlocking disconnect switch are standard.

**CUSTOM BUILT DUCT HEATERS - SLIP-IN or FLANGE CONNECTION**

Our custom designed duct heaters are built to the same quality standards as our regular line of electric duct heaters. These open coil duct heaters can be used in most constant or variable volume HVAC duct systems where space permits. This duct heater design allows for stand-alone operation or as an addition to existing air terminal units in VAV systems.

**ETL LISTED and APPROVED to UL STANDARDS**

Carnes custom duct heaters have been tested and certified to the American Standard # **UL STD 1996 UL** File Number E245517.

**PRODUCT QUALITY and SAFETY**

All Custom electric heater components have been selected following the same stringent selection procedure as our standard units. Our custom heaters also include the same safety devices utilized on our standard heaters. For specific information regarding optional and standard components, safety features or construction of our heaters, see the appropriate section of this catalog. Heaters are quality built by Indeeco.

**ORDERING INFORMATION – Custom Built Electric Duct Heater**

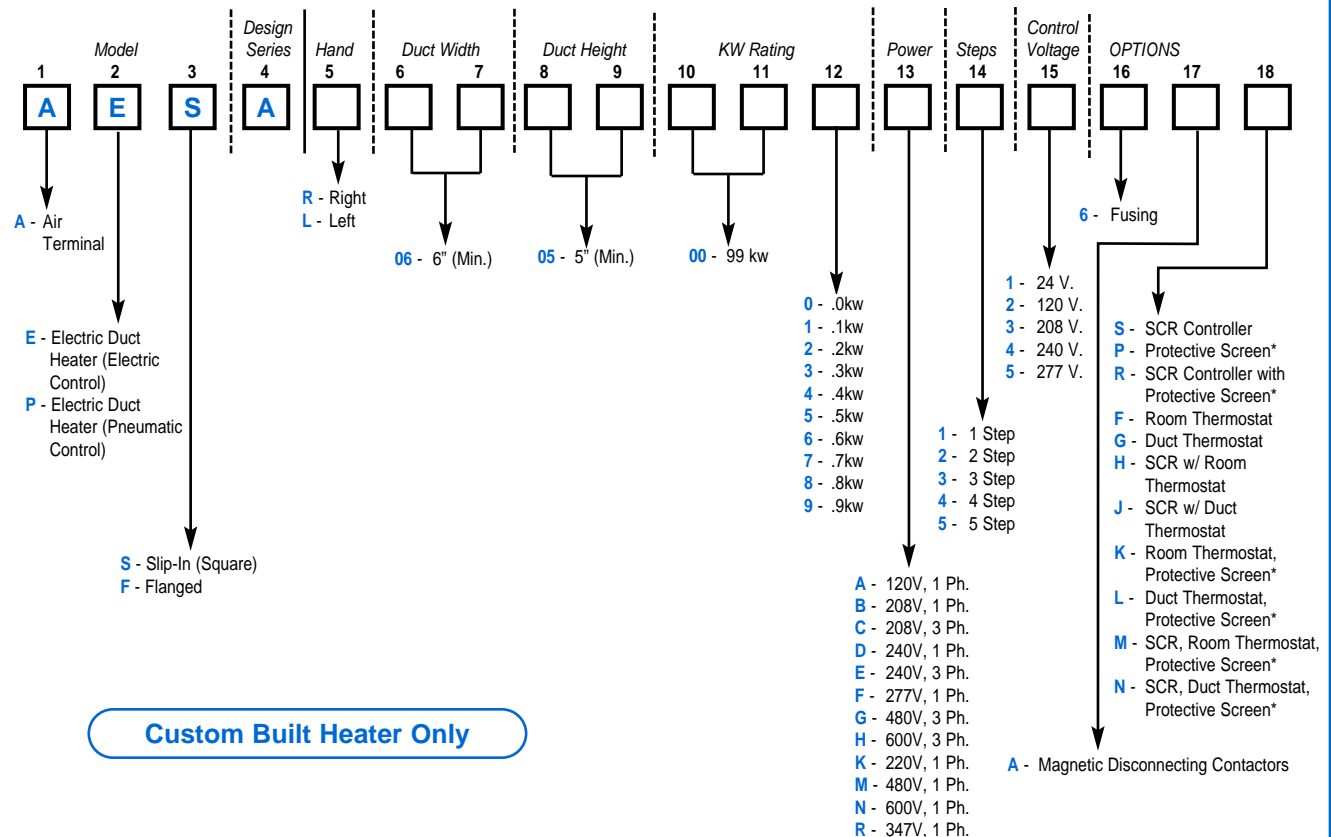

\*Protective screens are to be field installed.