

IP [English] Dimensions
Listed In Inches

MODEL VCDD/VCDC CEILING AND CABINET FANS
VXCBA IN-LINE ADAPTERS

CARNES COMPANY, 448 S. Main St., P. O. Box 930040, Verona, WI. 53593-0040 Phone: 608/845-6411 Fax: 608/845-6470 carnes@carnes.com www.carnes.com _____

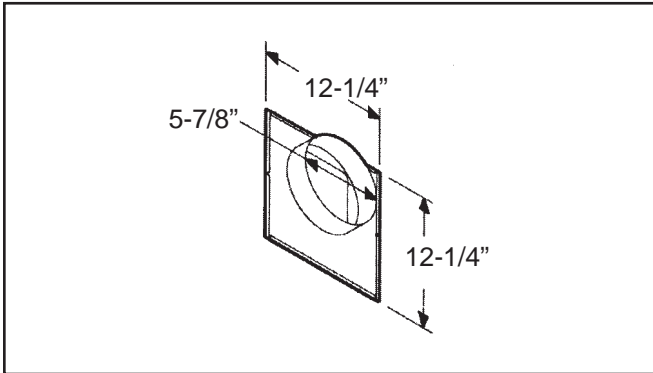

MODEL VXCBA A — IN-LINE ADAPTER KIT

- Galvanized steel.
- Fits VCDD 010C & 015C.
- 6" round duct connection.
- Mounting hardware included.

MODEL VXCBA B — IN-LINE ADAPTER KIT

- Galvanized steel.
- Fits VCDD 020C, 025C & 030C.
- 8" round duct connection.
- Mounting hardware included.

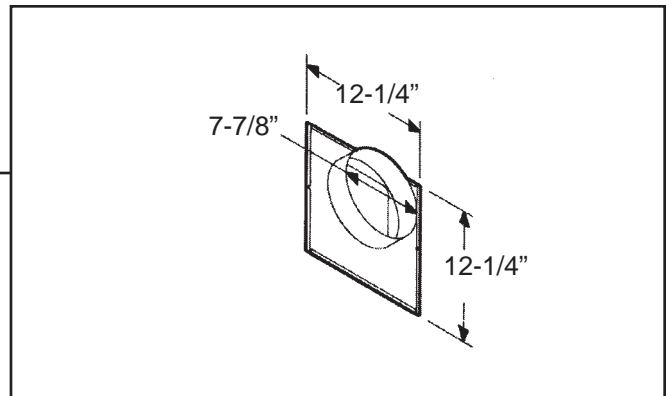

MODEL VXCBA C — IN-LINE ADAPTER KIT

- Galvanized steel.
- Fits VCDD 040C, 050C & 070C.
- 4-1/2" x 8-1/2" duct connection.
- Mounting hardware included.

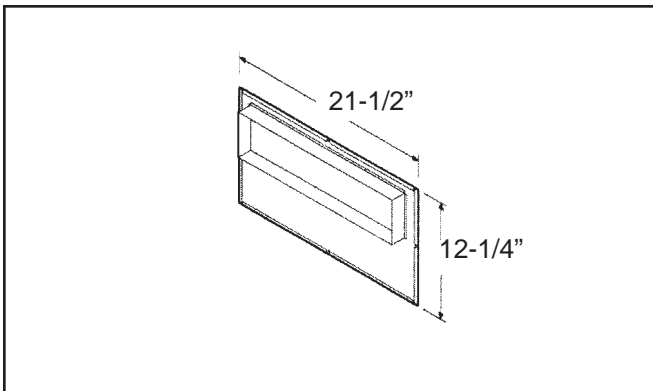

MODEL VXCBA D — IN-LINE ADAPTER KIT

- Galvanized steel.
- Fits VCDD 090C & 150C.
- 8" x 1/2" duct connection.
- Mounting hardware included.

