



LOW PROFILE ROOF MOUNTED DIRECT DRIVE VELK – Size 06

Carnes Low Profile Direct Drive Roof Exhauster Model VELK is available with 3 different 3-speed motors with capacities from 200 - 500 CFM. The unit features an attractive one piece cover, and rugged aluminum construction to ensure durability and dependability of operation.

▼ TYPICAL SPECIFICATIONS

VELK Direct Drive Low Profile Centrifugal Power Roof Ventilator Roof Exhaust Fans shall be of the centrifugal direct drive low profile type. The wheel and inlet venturi shall be of spark resistant construction. For maximum performance and quiet, efficient operation, the dynamically balanced wheel will have backward inclined median airfoil blades. The motor will be isolated from the exhaust airstream. Maximum exhaust temperature for continuous operation is 150°F. The motor will consist of 3 speeds and be permanently lubricated with sealed ball bearings. The motor shall be factory wired to a disconnect plug. A conduit chase will be provided for running electrical wire through the curb cap into the motor compartment. Field wiring of motor, disconnect, and conduit will be in accordance with electrical specifications and local codes. Heavy gauge birdscreen shall be furnished. Motors will be factory mounted and the units will be factory run tested prior to shipment. Low Profile Direct Drive Centrifugal Power Roof Ventilators shall be Carnes Company Model VELK.

CONSTRUCTION FEATURES



Removable One Piece Motor Cover

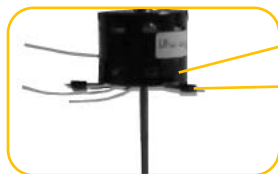

3 Speed Motor
Integral Mounting Brackets & Vibration Isolation



Fan Plate



Backward Inclined Wheel



Structural Support Brackets



Pre-punched Curb Cap

MOTOR COVER

- Heavy gauge spun aluminum.
- Louvers provide positive ventilation.

MOTOR/ELECTRICAL

- 3 speed motor standard.
- Plug type disconnect.
- Sealed conduit chase complies with NEC, allows wiring to pass from motor compartment through curb cap.
- Junction box for incoming power connection.

BIRDSCREEN

- 1/2" x 1/2" heavy gauge galvanized construction.

WHEEL

- Backward inclined type.
- Integral cooling fins to draw air over the motor.

CURB CAP

- One piece construction with fastened, overlapping corners to ensure strength.
- Pre-punched mounting holes for ease of installation.
- Support structure attached with self-sealing fasteners.

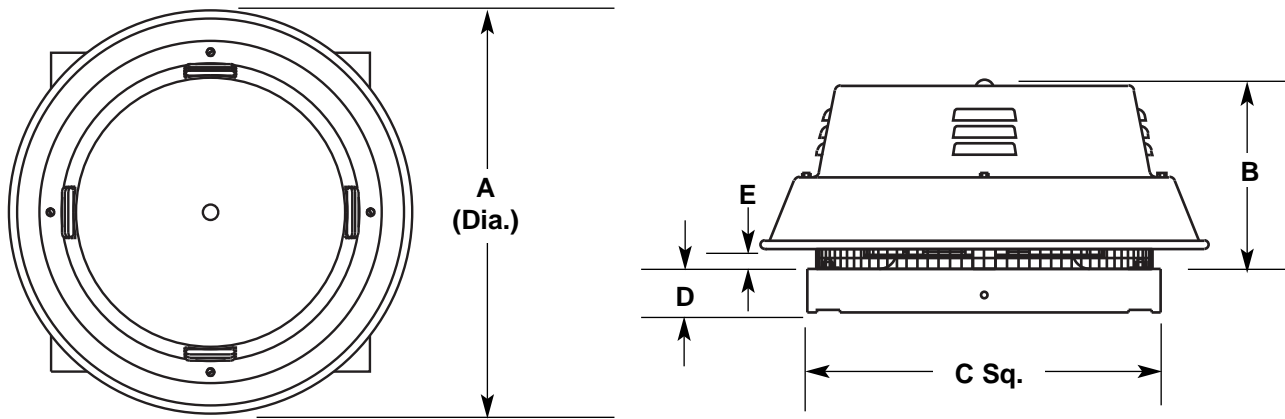

| Standard Material Thickness (Inches) | | | | | |
|--------------------------------------|-----------------|------------------|---------------------------|-------------------|--------------------------|
| Unit Size | Housing (Alum.) | Curb Cap (Alum.) | Std. Wheel Blades (Alum.) | Fan Plate (Alum.) | Support Brackets (Alum.) |
| 06 | .050 | .050 | Alum. | .080 | .125 |

| Standard Dimensions (Inches) | | | | | | | | | |
|------------------------------|-----------------|---------------|-------------------|-----|------------------|----------------|-----------------|--------------|--------------------------|
| Unit Size | Unit Diameter A | Unit Length B | Inside Curb Cap C | E | Curb Cap Width D | Curb O. D. Sq. | Damper Size Sq. | Roof Opening | Max. Unit Weight W/Motor |
| 06 | 19-1/2 | 8 | 15-1/2 | 3/4 | 1-7/8 | 14 | 10 | 11 | 16 |

MODEL VELK — PERFORMANCE DATA

| Size | Motor HP | Motor RPM | STATIC PRESSURE, INCHES W. G. | | | | | | | | | |
|--------------|----------|-----------|-------------------------------|----------|-----------|-----------|-----------|-----------|-----------|-----------|-----------|-----------|
| | | | 0.0 | .1 | .125 | .2 | .25 | .3 | .375 | .4 | .5 | .625 |
| | | | CFM Sones | CFM Sone | CFM Sones | CFM Sones | CFM Sones | CFM Sones | CFM Sones | CFM Sones | CFM Sones | CFM Sones |
| 06 A1 (High) | 1/20 | 1550 | 432 | 388 | 380 | 351 | 331 | 304 | 256 | 240 | 170 | 51 |
| | | | 8.7 | 8.5 | 8.4 | 8.2 | 8.1 | 8.1 | 8.0 | 8.0 | 8.0 | 8.0 |
| 06 A1 (Med) | 1/20 | 1450 | 407 | 364 | 354 | 320 | 293 | 264 | 217 | 201 | 118 | |
| | | | 7.9 | 7.5 | 7.4 | 7.2 | 7.0 | 7.0 | 6.8 | 6.8 | 7.0 | |
| 06 A1 (Low) | 1/20 | 1175 | 329 | 276 | 264 | 212 | 173 | 133 | 24 | | | |
| | | | 7.0 | 6.3 | 6.1 | 5.7 | 5.7 | 5.6 | 5.6 | | | |
| 06 B1 (High) | 1/40 | 1325 | 397 | 349 | 336 | 297 | 264 | 224 | 165 | 135 | | |
| | | | 7.2 | 6.8 | 6.6 | 6.3 | 6.2 | 6.1 | 6.0 | 6.0 | | |
| 06 B1 (Med) | 1/40 | 1200 | 362 | 304 | 291 | 235 | 194 | 153 | 32 | | | |
| | | | 6.4 | 5.9 | 5.8 | 5.5 | 5.4 | 5.3 | 5.4 | | | |
| 06 B1 (Low) | 1/40 | 1000 | 299 | 229 | 209 | 148 | 74 | | | | | |
| | | | 5.7 | 4.8 | 4.5 | 4.2 | 4.0 | | | | | |
| 06 G1 (High) | 1/85 | 900 | 259 | 186 | 159 | | | | | | | |
| | | | 4.1 | 3.7 | 3.7 | | | | | | | |
| 06 G1 (Med) | 1/85 | 755 | 217 | 50 | | | | | | | | |
| | | | 3.2 | 2.7 | | | | | | | | |
| 06 G1 (Low) | 1/85 | 575 | 159 | 3 | | | | | | | | |
| | | | 1.5 | 1.2 | | | | | | | | |

Performance certified is for installation type A: Free inlet, Free outlet.

Performance ratings do not include effects of accessories.

Speed (RPM) shown is nominal. Performance is based on actual speed of test.

The sound ratings shown are loudness values in fan sones at 5 feet (1.5m) in a hemispherical free field calculation per AMCA Standard 301. Values shown are for installation "Type A" free inlet hemispherical sone levels.



LOW PROFILE UPBLAST & WALL DIRECT DRIVE VULK – Size 06

Carnes Low Profile Upblast and Wall Direct Drive Exhauster Model VULK is available with 3 different 3-speed motors with capacities from 200 - 425 CFM. The unit features an attractive spun shroud, spun motor cover, and rugged aluminum construction to ensure durability and dependability of operation.

▼ TYPICAL SPECIFICATIONS

VULK Direct Drive Low Profile Upblast Roof and Wall Centrifugal Ventilators shall be of the centrifugal direct drive low profile type. The wheel and inlet venturi shall be of spark resistant construction. For maximum performance and quiet, efficient operation, the dynamically balanced wheel will have backward inclined median airfoil blades. The motor will be isolated from the exhaust airstream. Maximum exhaust temperature for continuous operation is 150°F. The motor will consist of 3 speeds and be permanently lubricated with sealed ball bearings. The motor shall be factory wired to a disconnect plug. A conduit chase will be provided for running electrical wire through the curb cap into the motor compartment. Field wiring of motor, disconnect, and conduit will be in accordance with electrical specifications and local codes. Heavy gauge birdscreen shall be furnished. Motors will be factory mounted and the units will be factory run tested prior to shipment. The unit shall be suitable for wall or roof use. Low Profile Upblast and Wall Direct Drive Centrifugal Ventilators will be Carnes Company Model VULK.

CONSTRUCTION FEATURES



Removable One Piece Motor Cover

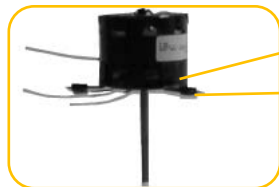

3 Speed Motor
Integral Mounting Brackets & Vibration Isolation



Fan Plate



Backward Inclined Wheel



Structural Support Brackets



Upblast Shroud



Pre-punched Curb Cap

MOTOR COVER

- Heavy gauge spun aluminum.
- Vent tube provides positive ventilation.

UPBLAST SHROUD

- Heavy gauge spun aluminum.
- Beaded for strength.

MOTOR/ELECTRICAL

- 3 speed motor standard.
- Plug type disconnect.
- Sealed conduit chase complies with NEC, allows wiring to pass from motor compartment through curb cap.
- Junction box for incoming power connection.

BIRDSCREEN

- 1/2" x 1/2" heavy gauge galvanized construction.

WHEEL

- Backward inclined type.
- Integral cooling fins to draw air over the motor.

CURB CAP

- One piece construction with fastened, overlapping corners to ensure strength.
- Pre-punched mounting holes for ease of installation.
- Support structure attached with self-sealing fasteners.

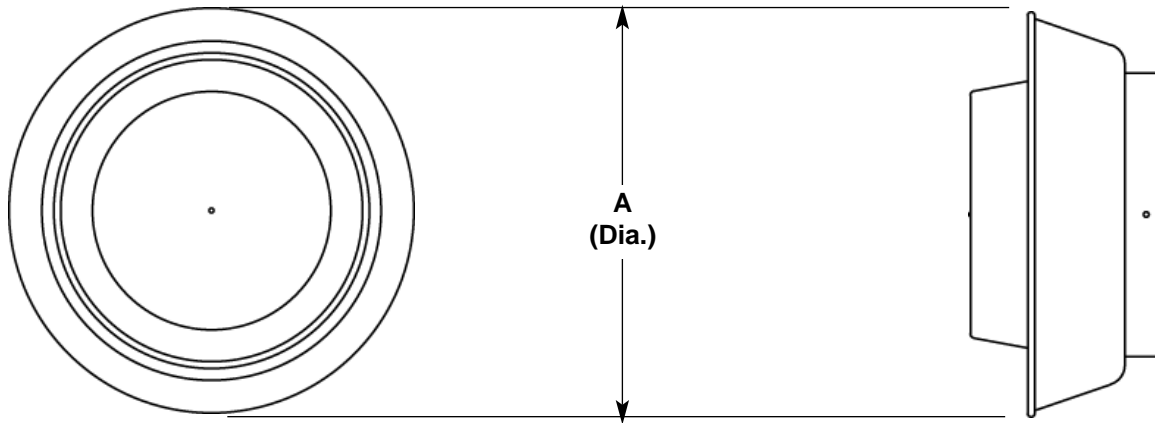

| Standard Material Thickness (Inches) | | | | | |
|--------------------------------------|-----------------|------------------|---------------------------|-------------------|--------------------------|
| Unit Size | Housing (Alum.) | Curb Cap (Alum.) | Std. Wheel Blades (Alum.) | Fan Plate (Alum.) | Support Brackets (Alum.) |
| 06 | .050 | .050 | Alum. | .080 | .125 |

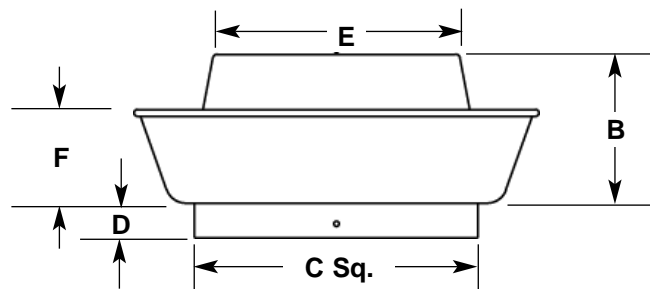

| Standard Dimensions (Inches) | | | | | | | | | | |
|------------------------------|-----------------|---------------|-------------------|---------------|------------------|----------------|-----------------|--------------|--------------------------|-----------------|
| Unit Size | Unit Diameter A | Unit Length B | Inside Curb Cap C | Motor Cover E | Curb Cap Width D | Curb O. D. Sq. | Damper Size Sq. | Roof Opening | Max. Unit Weight W/Motor | Shroud Height F |
| 06 | 22-1/4 | 8 | 15-1/2 | 13-1/2 | 1-7/8 | 14 | 10 | 11 | 16 | 5 |

MODEL VULK — PERFORMANCE DATA

| Size | Motor HP | Motor RPM | STATIC PRESSURE, INCHES W. G. | | | | | | | | | | |
|--------------|----------|-----------|-------------------------------|------|-------|-------|-------|-------|-------|-------|-------|-------|-------|
| | | | 0.0 | .1 | .125 | .2 | .25 | .3 | .375 | .4 | .5 | .625 | |
| | | | CFM | CFM | CFM | CFM | CFM | CFM | CFM | CFM | CFM | CFM | |
| | | | Sones | Sone | Sones | Sones | Sones | Sones | Sones | Sones | Sones | Sones | Sones |
| 06 A1 (High) | 1/20 | 1550 | 423 | 396 | 389 | 364 | 343 | 328 | 288 | 274 | 219 | 107 | |
| | | | 8.8 | 8.7 | 8.6 | 8.5 | 8.4 | 8.3 | 8.1 | 8.0 | 7.7 | 6.8 | |
| 06 A1 (Med) | 1/20 | 1450 | 398 | 368 | 360 | 334 | 313 | 286 | 232 | 214 | 127 | | |
| | | | 8.1 | 7.8 | 7.8 | 7.6 | 7.4 | 7.2 | 6.9 | 6.8 | 6.6 | | |
| 06 A1 (Low) | 1/20 | 1175 | 323 | 281 | 272 | 228 | 192 | 156 | | | | | |
| | | | 7.2 | 6.7 | 6.5 | 6.1 | 6.1 | 6.0 | | | | | |
| 06 B1 (High) | 1/40 | 1325 | 345 | 313 | 303 | 270 | 239 | 209 | 163 | 148 | | | |
| | | | 7.1 | 6.6 | 6.5 | 6.2 | 6.0 | 5.7 | 5.5 | 5.5 | | | |
| 06 B1 (Med) | 1/40 | 1200 | 313 | 275 | 260 | 207 | 171 | 135 | 42 | | | | |
| | | | 5.8 | 5.0 | 4.9 | 4.6 | 4.6 | 4.6 | 4.9 | | | | |
| 06 B1 (Low) | 1/40 | 1000 | 262 | 212 | 190 | 123 | 77 | | | | | | |
| | | | 4.9 | 4.2 | 4.0 | 4.2 | 4.4 | | | | | | |
| 06 G1 (High) | 1/85 | 900 | 237 | 172 | 149 | | | | | | | | |
| | | | 4.1 | 3.8 | 3.7 | | | | | | | | |
| 06 G1 (Med) | 1/85 | 755 | 203 | 122 | | | | | | | | | |
| | | | 3.3 | 2.6 | | | | | | | | | |
| 06 G1 (Low) | 1/85 | 575 | 137 | 132 | | | | | | | | | |
| | | | 1.3 | 1.0 | | | | | | | | | |

Performance ratings do not include effects of accessories.
 Performance certified is for installation type A: Free inlet, Free outlet.
 Speed (RPM) shown is nominal. Performance is based on actual speed of test.
 The sound ratings shown are loudness values in fan sones at 5 feet (1.5m) in a hemispherical free field calculation per AMCA Standard 301. Values shown are for installation "Type A" free inlet hemispherical sone levels.

THREE SPEED MOTOR DESCRIPTION

Carnes models **VELK** and **VULK** are equipped with three-speed ODP motors as standard. These motors each feature three very distinct speeds and horsepower, as shown in the performance charts on C-2 of this catalog. These motors can be wired direct or dedicated to a particular speed. For example, the motor can be “hard” wired to high speed and the fan will always run on the high speed. These motors can also be wired to a three-speed switch, allowing speed changes between high-medium-low.

TYPICAL WIRING DIAGRAMS — (ALL MOTORS)

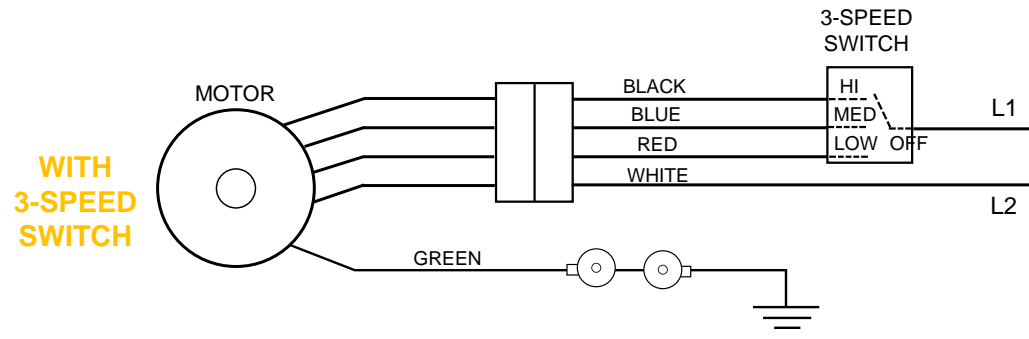
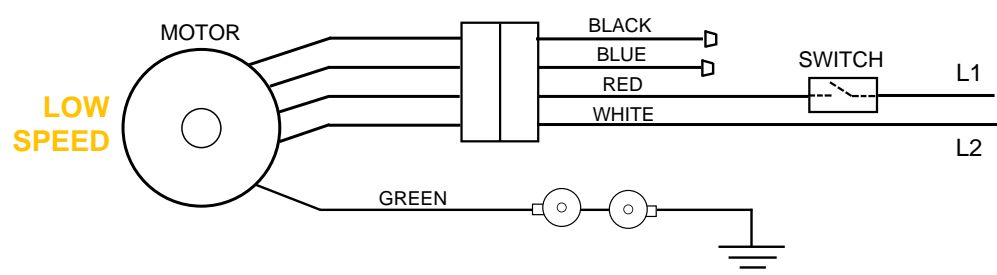
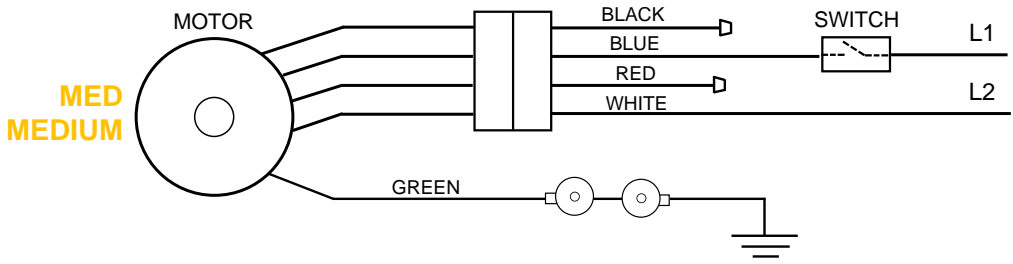
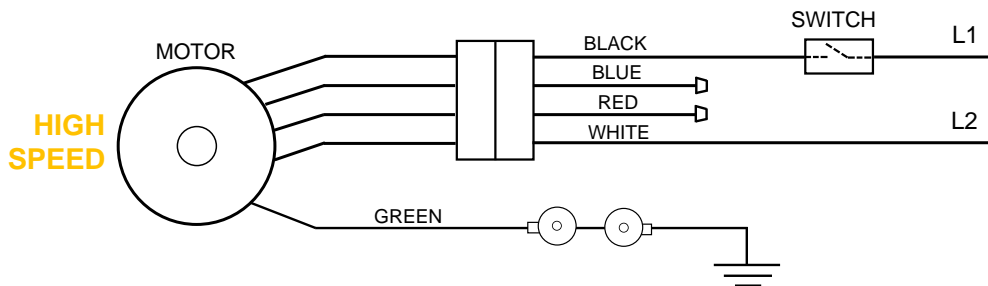

Figure 1

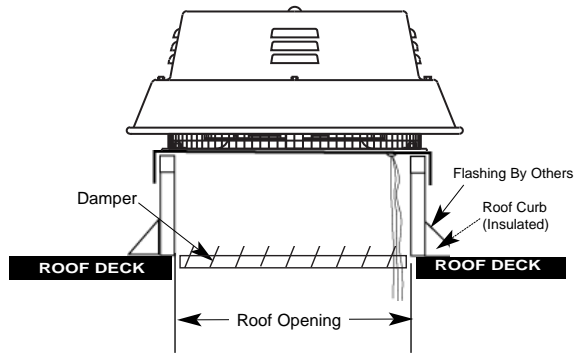

Figure 2

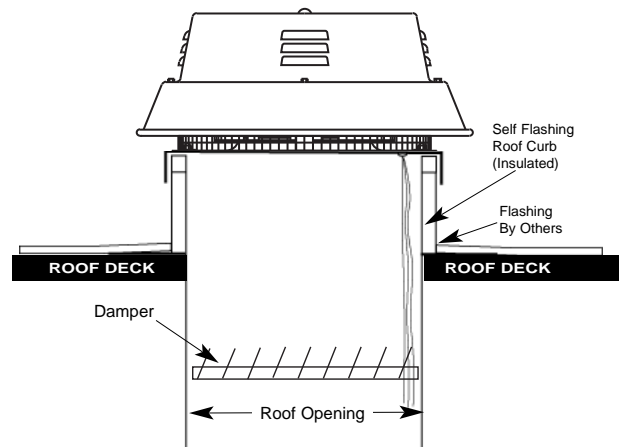

Figure 3

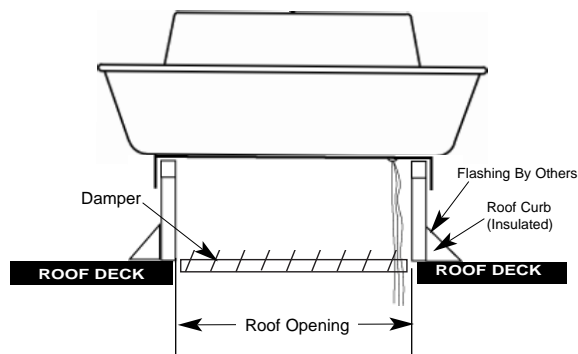

Figure 4

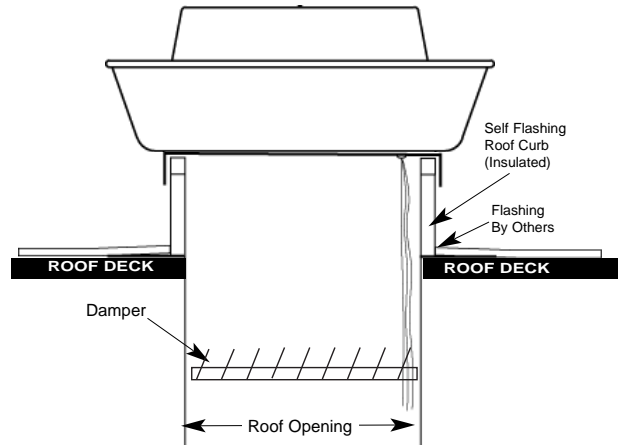
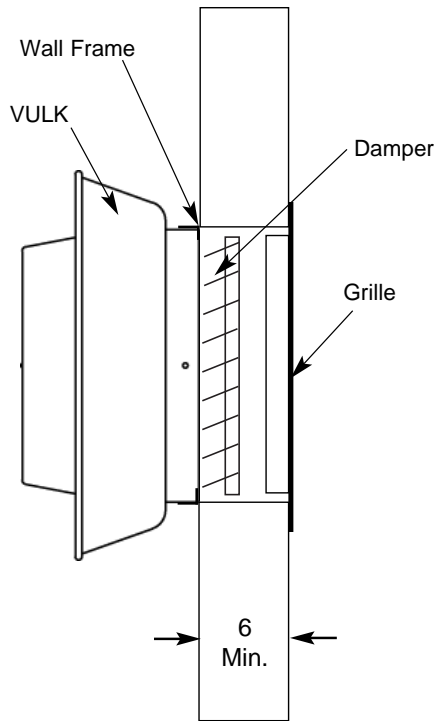

Figure 1 shows a typical Model VELK Low Profile Downblast Power Roof Ventilator & Figure 3 shows a typical Model VULK Low Profile Upblast Power Roof Ventilator installed without duct work. The roof flashing is shown installed over a standard canted style roof curb. A gravity operated backdraft damper is shown installed on the damper shelf which is located at the base of the roof curb. Power wiring is extended through the roof opening, through the damper conduit knockout, into the fan wiring chase and connected to the factory wiring leads.

Figure 2 shows a typical Model VELK Low Profile Downblast Power Roof Ventilator & Figure 4 shows a typical Model VULK Low Profile Upblast Power Roof Ventilator installed with an exhaust duct. The duct is shown extending through the roof opening and inside a typical self flashing style roof curb. A gravity operated backdraft damper is shown fastened to a 3/4" x 3/4" sheet metal angle installed inside the exhaust duct. Power wiring is extended through the roof opening, through the damper conduit knockout, into the fan wiring chase and connected to the factory wiring leads.

Figure 5



**Figure 5
NON-DUCTED
Sidewall Installation**

Figure 6

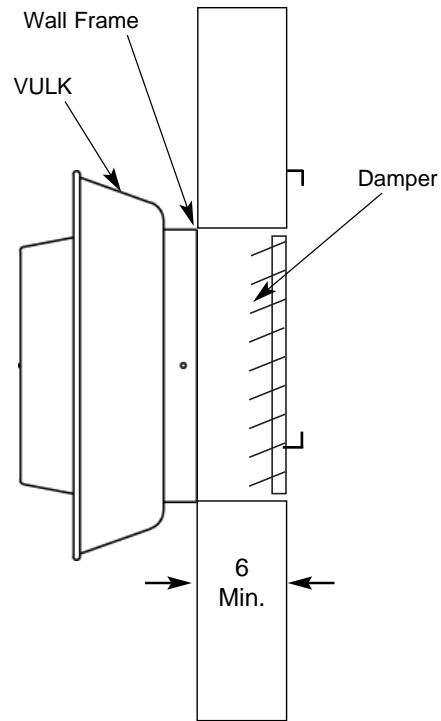

**Figure 6
DUCTED
Sidewall Installation**

Figure 5 shows a typical Model VULK Sidewall ventilator installed without duct work. The fan is mounted to the wall by a factory provided wall mounting frame. A gravity operated backdraft damper is shown installed in the wall, with a wall grille on the inside of the wall. Power wiring is extended through the wall opening, through the damper conduit knockout, into the fan wiring chase, and connected to the factory wiring leads.

Figure 6 shows a typical Model VULK Sidewall ventilator installed with an exhaust duct. The duct is shown extending through the wall opening. The fan is mounted to the wall by a factory provided wall mounting frame. A gravity backdraft damper is shown installed in the ductwork. Power wiring is extended through the wall opening, through the damper conduit knockout, into the fan wiring chase, and connected to the factory wiring leads.

Proper fan performance requires uniform and stable air flow at the fan inlet. Avoid transitions, obstructions, elbows or other duct fittings near the fan inlet.

Typical roof curb height is 8" to 12" above the roof deck. Additional height reduces the likelihood of snow or rain entering through the roof opening.

Installation and electrical work should be performed by qualified personnel and must be in accordance with all applicable code requirements.

For protection of personnel, inlet guards are recommended when the fan is within reach (or within 7 feet) of occupied areas or work areas.

Model VELK and VULK - Low Profile Ventilators

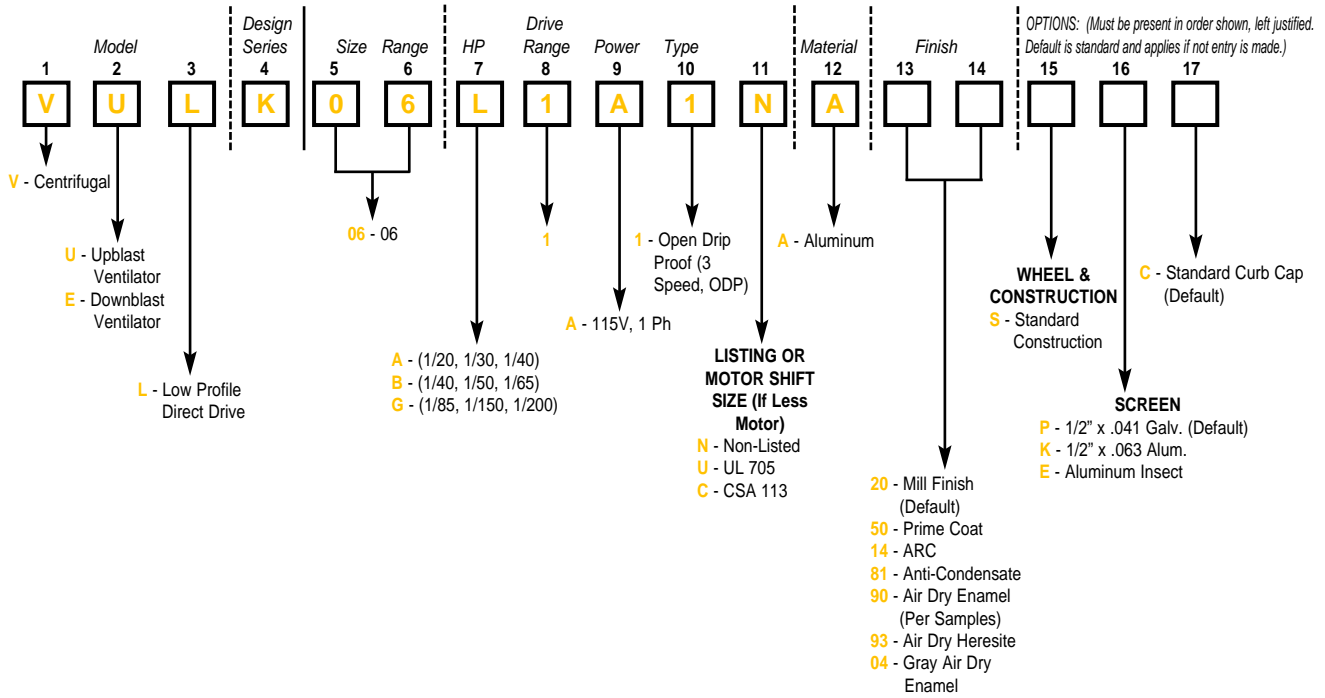

▼ Dampers

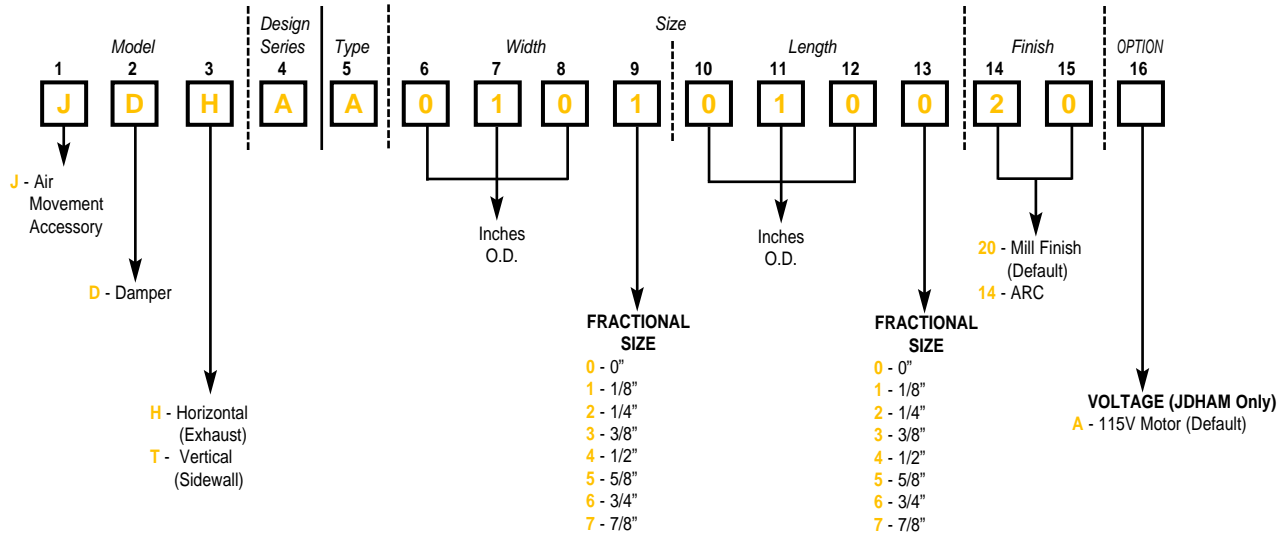

▼ Curbs

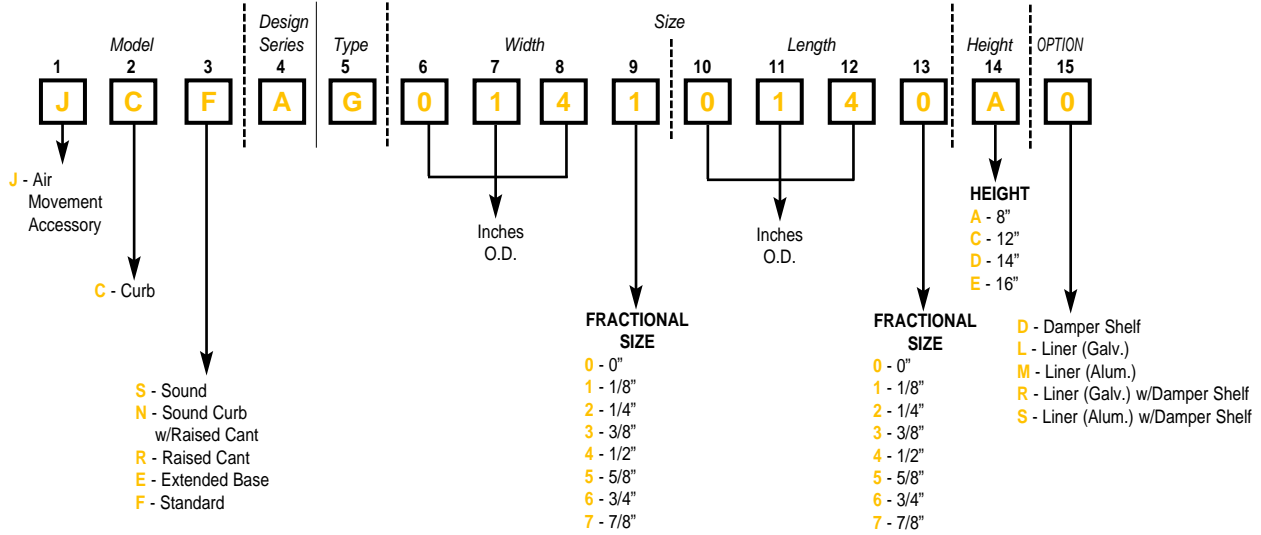

▼ Electrical Accessories

