

▼ Roof Curbs

STANDARD CONSTRUCTION

Heavy gauge galvanized steel, utilized full mitered corners, all seams welded, 1-1/2" thick rigid fiberglass insulation, wood nailer strip. All curbs are internally reinforced in larger size dimensions.

CURB SIZE DESIGNATION

First 3 digits "A" dimension in inches, 4th digit number of eighths in fraction (1/2" is 4 eighths). Size 24-1/2" x 36" would be:

SIZE: 0244 0360.

CURB DIMENSIONS

- A = Unit Curb Cap — 1-1/2" (Curb Size O.D.)
- B = A - 3" (Curb I. D.)
- C = A + 8" (Base O. D.)
- D = 8" or 12" (Curb Height) other Heights available.

Models:

- VELK/VULK
- VEDK/VEBK
- VUDK/VUBK
- VLDK/VLBK
- VTDK/VTBK
- VRBK (Liner Needed)
- Gravity Hoods

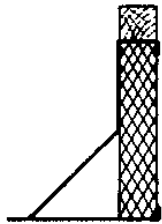
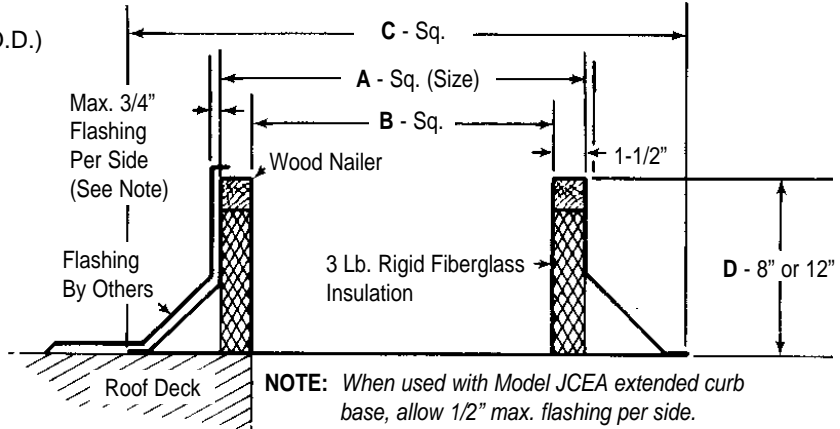

MODELS —
JCFAG - Galvanized
JCFAA - Aluminum
 Standard Height — 8" or 12". Also available with Option L - Interior Liner.

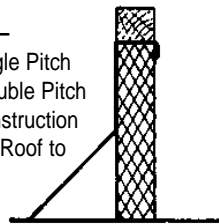

MODELS —
JCPA - Single Pitch
JCDA - Double Pitch
 Similar Construction for Pitched Roof to 9" per foot.

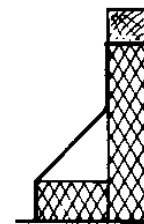

MODEL - JCRA
 Raised Cant
 Standard 1-1/2"
 Raised Cant ADDS 1-1/2" to Height

▼ Self-Flashing Roof Curbs — Model JCVB

FOR USE WITH MODEL VRBK RESTAURANT EXHAUST FAN

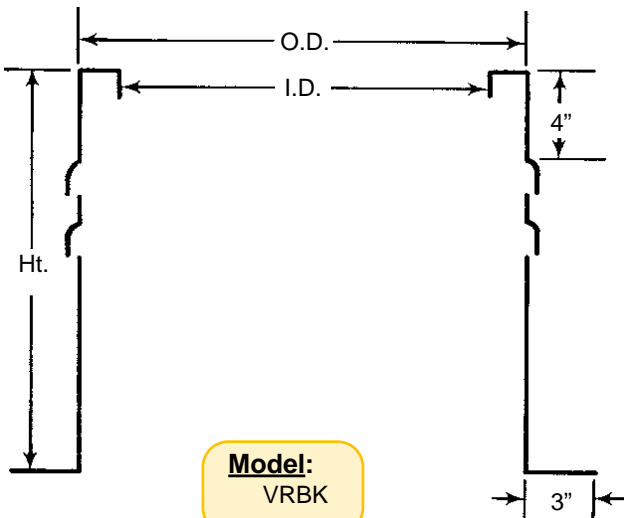

Model:
 VRBK

CURB SIZE DESIGNATION

First 3 digits "A" Dimension in inches, 4th digit number of eighths in fraction (1/2" is 4 eighths). Size 24-1/2" x 36" would be
 SIZE: 0244 0360.

ALL DIMENSIONS LISTED IN INCHES

VRBK SIZE	CURB CAP ID	CURB O.D.	CURB I.D.	CURB HT.*
06	15-1/2	15	12	26
08	15-1/2	15	12	26
10	17-5/8	17	14	24
12	17-5/8	17	14	24
15	20-1/2	20	17	20
18	25	24-1/2	21-1/2	18
21	28-1/8	27-1/2	24-1/2	18
24	31-1/8	30-1/2	27-1/2	18
30	40-1/8	39-1/2	36-1/2	18
36	46-1/8	45-1/2	42-1/2	18
42	54-1/8	53-1/2	50-1/2	18
48	58-1/8	57-1/2	54-1/2	18

STANDARD CONSTRUCTION

- Continuously welded 18 gauge galvanized steel.
- Neoprene gasketing (For Field Installation).
- 5" wide by 1" high louvered slots, 4 per side, on all sides.
- No insulation; no wood nailer.
- Aluminum construction optional.

*Curb height selected to allow 18" welded duct height and maintain 40" discharge height required per NFPA 96.

▼ Self-Flashing Roof Curb — Model JCHAG (Galvanized), Model JCHAA (Aluminum)

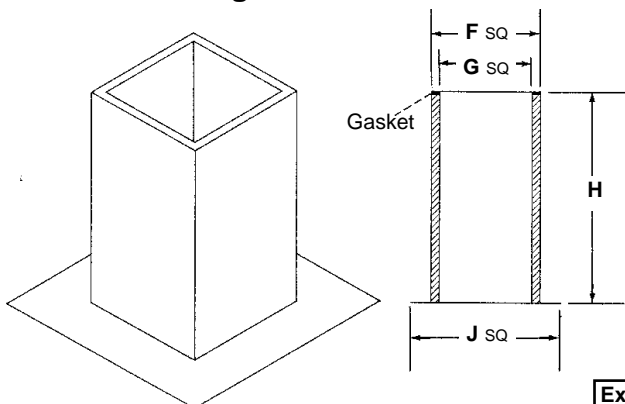

CONSTRUCTION

- 18 ga. galvanized steel (*Standard*).
- 16 ga. (.050) aluminum (*Optional*).
- Continuously welded corners.
- Mitered and wedged flanges - 3-1/2" wide.
- Rubber or neoprene gasket.
- 1-1/2" 3 lb./ft.³ fiberglass insulation.

NOTE: OD equals fan cap minus 1/2".

DIMENSIONS LISTED IN INCHES

Exhauster Size	F SQ. Curb O.D.	G. SQ. Curb I.D.	Max. Roof Opening	J SQ. Flange O.D.	H Height
06	15	12	12	22	
08	15	12	12	22	
10	17	14	14	24	
12	17	14	14	24	
15	20	17	17	27	
18	24-1/2	21-1/2	21-1/2	31-1/2	
21	27-1/2	24-1/2	24-1/2	34-1/2	
24	30-1/2	27-1/2	27-1/2	37-1/2	
30	39-1/2	36-1/2	36-1/2	46-1/2	
36	45-1/2	42-1/2	42-1/2	52-1/2	
42	53-1/2	50-1/2	50-1/2	60-1/2	
48	57-1/2	54-1/2	54-1/2	64-1/2	
54	63-1/2	60-1/2	60-1/2	70-1/2	

Models:

- VEDK/VEBK
- VUDK/VUBK
- VRBK
- VELK/VULK
- VLDK/VLBK
- VTDK/VTBK
- VSBB/VHBB
- Gravity Hoods

▼ Curb Prefabricated Pitched — Models JCPA and JCDA

SINGLE PITCH — JCPA

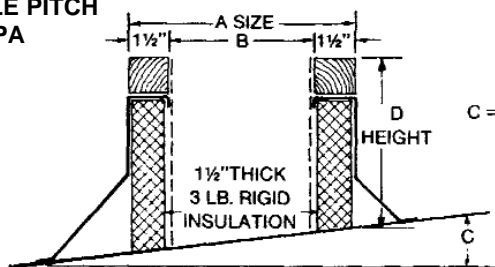

FIGURE 1. Prefabricated (Single Pitched) construction thru 9" rise per foot.

DOUBLE PITCH — JCDA

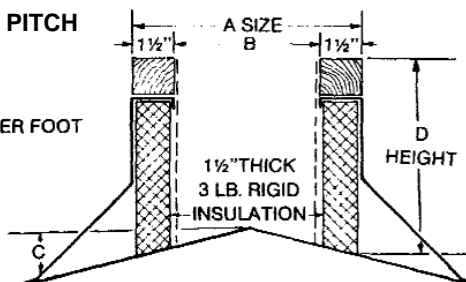

FIGURE 2. Prefabricated (Double Pitched) up thru 3" rise per foot.

STANDARD FEATURES

1. Factory installed wood nailer.
2. Welded 18 ga. galvanized steel shell and base plate.
3. 1-1/2" thick, 3 lb. rigid insulation.
4. Fully mitered 3" cant.

Models:

- VEDK/VEBK
- VUDK/VUBK
- VLDK/VLBK
- VTDK/VTBK
- Gravity Hoods
- VSBB/VHBB
- VRBK (*Liner Needed*)

NOTE: When used with Model JCEA extended curb, 1/2" max. flashing per side.

Used with CARNES VENTILATOR MODEL AND SIZE

VE, VU, VL, VT	GS	CURB SIZE	A	B	PITCH C	D
06-10		0140	14	11		
12		0160	16	13		
15	12	0190	19	16		
18		0230	23	20		
	16	0234	23-1/2	20-1/2		
		0244	24-1/2	21-1/2		
	22	0270	27	24		
24		0294	29-1/2	26-1/2		
	28	0354	35-1/2	32-1/2		
30		0384	38-1/2	35-1/2		
	32	0414	41-1/2	38-1/2		
36		0444	44-1/2	41-1/2		
	38	0474	47-1/2	44-1/2		
44		0524	52-1/2	49-1/2		
	46-52	0554	55-1/2	52-1/2		
54		0624	62-1/2	59-1/2		
	60	0654	65-1/2	62-1/2		

▼ Sound Curb — Model JCSA

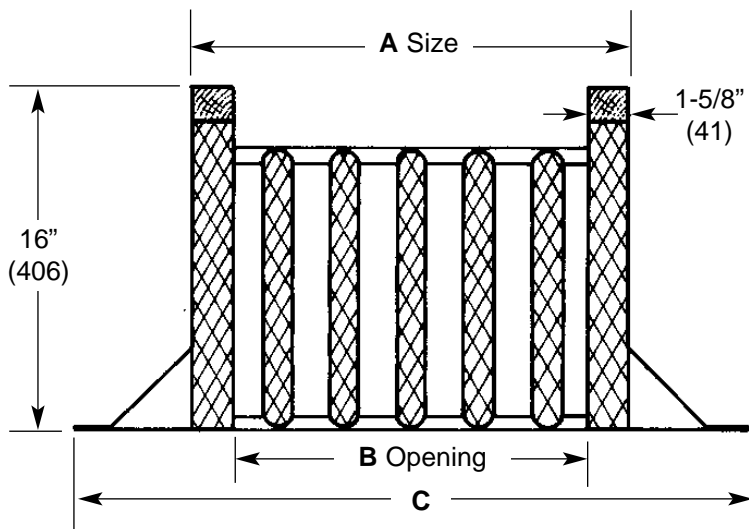

Models:

- VEDK/VEBK
- VUDK/VUBK
- VLDK/VLBK
- VTDK/VTBK

APPLICATION

Select ventilator for 4% additional CFM to overcome typical performance loss over standard curb. Catalog sone ratings will be reduced approximately 40% (.6 x catalog sones = sones with JCSA Curb).

NOTES

Backdraft dampers must be mounted in duct below curb.

STANDARD FEATURES

- 1-1/2" (38) thick 3 lb. density rigid fiberglass insulation.
- 3" x 3" (76 x 76) cant strip.
- 18 ga. (.052) galvanized steel construction.
- 1" (25) thick 3 lb. rigid insulation baffles.
- Removable baffle assembly.
- 22 Ga. galvanized baffles, 5" (127) on center.

DIMENSIONS

- "A" = Curb Cap -1/2" (38) - [Curb OD]
- "B" = "A" -3-1/4" (82) - [Curb ID]
- "C" = "A" +8" (203) - [Base OD]

▼ Canted Insulated Roof Curb — Model LXFAG

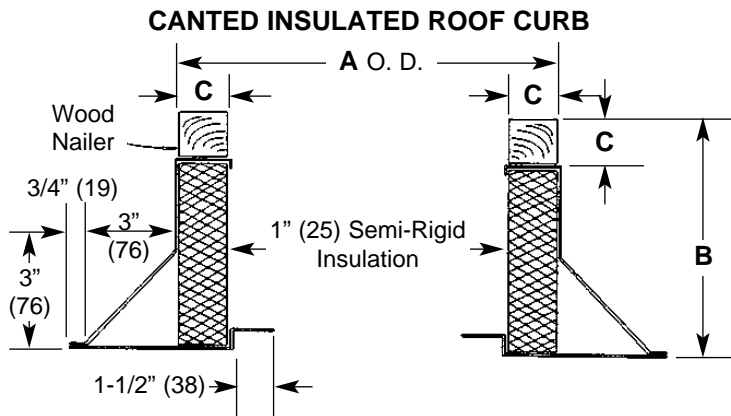

Models:

- LUDA
- LUBA
- LUKA
- LQBA
- LTBA/DA
- LGBA/DA
- LFGBA/DA

OPTIONS:

1. Insulation retainers - solid or screen type.
2. Burglar bars - 1/2" dia. on 8" centers.
or, 3/4" dia. on 6" centers.
3. Heights: 8, 12, or 16".
4. Single pitch, double pitch, or flat style.
5. Damper tray.

DIMENSIONS LISTED IN INCHES (Millimeters)

Fan Size	A" O. D. (Square) CURB / RF TYPE			"B" Curb Height	"C" Wood Nailer	Gauge	Weight Lbs./Kg.
	LUBA LUDA LUKA	LQBA	LGBA/DA LTBA/DA LFBA/DA				
24	31 (787)	33-1/4 (844)	33-1/4 (844)	8 (203)	1-1/2 (38)	18	39 (18)
30	37 (939)	39-1/4 (997)	39-1/4 (997)	8 (203)	1-1/2 (38)	18	46 (21)
36	43 (1092)	45-1/4 (1149)	45-1/4 (1149)	8 (203)	1-1/2 (38)	18	54 (25)
42	49 (1244)	51-1/4 (1301)	51-1/4 (1301)	8 (203)	1-1/2 (38)	18	61 (28)
48	55 (1396)	57-1/4 (1453)	57-1/4 (1453)	8 (203)	1-1/2 (38)	18	68 (31)
54	61 (1549)	63-1/4 (1606)	63-1/4 (1606)	8 (203)	1-1/2 (38)	18	75 (34)
60	67 (1701)	69-1/4 (1758)	69-1/4 (1758)	8 (203)	1-1/2 (38)	18	82 (37)
72	81 (2056)	83-1/4 (2113)	83-1/4 (2113)	8 (203)	1-1/2 (38)	18	99 (45)

Standard construction is shown. G-90 galvanized welded steel construction.

▼ Vented Curb Extension — Model JCEB

FOR USE WITH MODEL VRBK RESTAURANT EXHAUST FAN AND STANDARD ROOF CURB

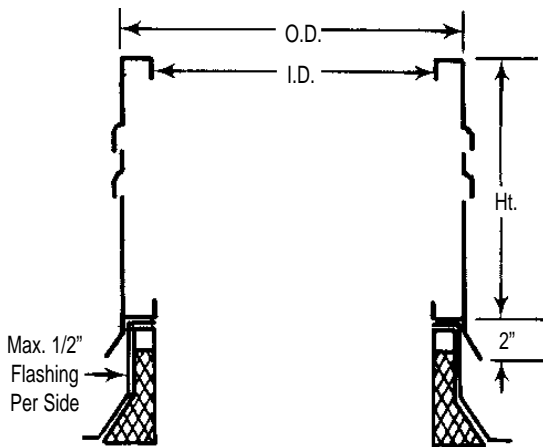

ALL DIMENSIONS LISTED IN INCHES

VRBK SIZE	CURB CAP ID	CURB O.D.	EXT. O.D. (SIZE)	EXT. I.D.	EXT. HT.*
06	15-1/2	14	15	12	18
08	15-1/2	14	15	12	18
10	17-5/8	16	17	14	16
12	17-5/8	16	17	14	16
15	20-1/2	19	20	17	12
18	25	23-1/2	24-1/2	21-1/2	10
21	28-1/8	26-1/2	27-1/2	24-1/2	10
24	31-1/8	29-1/2	30-1/2	27-1/2	10
30	40-1/8	38-1/2	39-1/2	36-1/2	10
36	46-1/2	44-1/2	45-1/2	42-1/2	10
42	54-1/8	52-1/2	53-1/2	50-1/2	10
48	58-1/8	56-1/2	57-1/2	54-1/2	10

Model:
VRBK

STANDARD CONSTRUCTION

- Continuously welded 18 gauge galvanized steel.
- Neoprene gasketing (For Field Installation).
- 5" wide by 1" high louvered slots, 4 per side, on all sides.
- No insulation; no wood nailer.
- Aluminum construction optional.

*Extension height based on use of 8" high curb. Extension height selected to allow 18" welded duct height and maintain 40" discharge height required per NFPA 96.

▼ Extended Base Curb — Model JCEA

NOTE: This Extension May Be Used With Carnes Curbs (or Curbs by others)

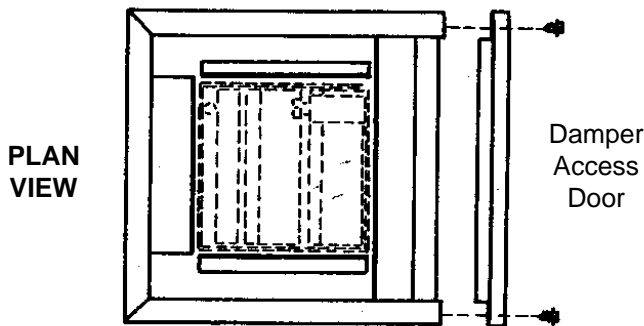

FIGURE 1: CURB — EXTENDED

- **Model JCEAG**—Galvanized (CXG)
- **Model JCEAA**—Aluminum (CXA)

Optional JDHAA, JDHAM or JDHAC Damper

Models:

- VEDK/VEBK
- VUDK/VUBK
- VTDK/VTBK
- VLDK/VLBK
- VELK/VULK
- VSBB/VHBB
- Gravity Hoods

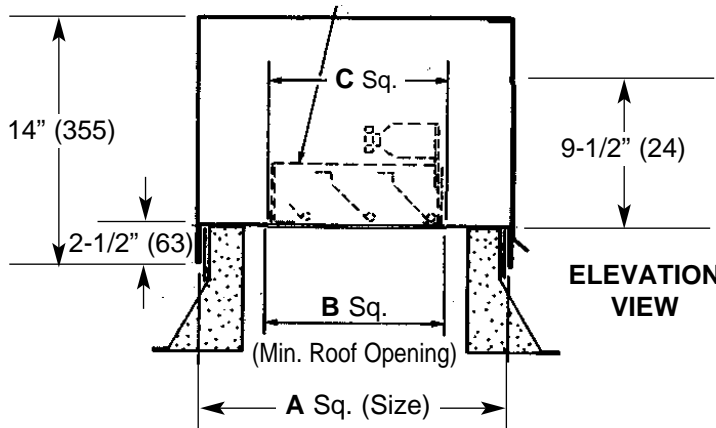

Built-Up Curb Must Be Sized To Allow For Flashing

- A = Curb O. D. plus 1-1/4" (32) [Extended Base Size]
- B = (See Unit Submittal Data)
- C = Damper Outside

▼ Hinged Curb Adapter for Vented (Model JCVB) and Self-Flashing Curbs (Model JCHA) — Model VXPB

Standard Construction:

- 20" and under = 18 gauge Galvanized Steel
- 20-1/2" through 30-1/2" = 16 gauge Galvanized Steel
- Above 30-1/2" = 14 gauge Galvanized Steel

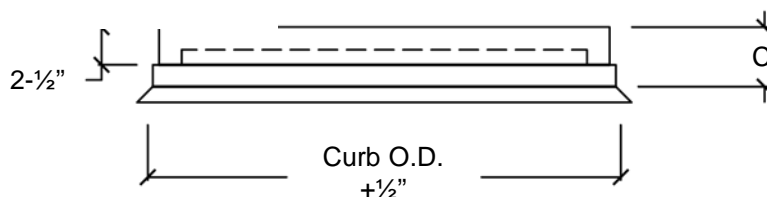
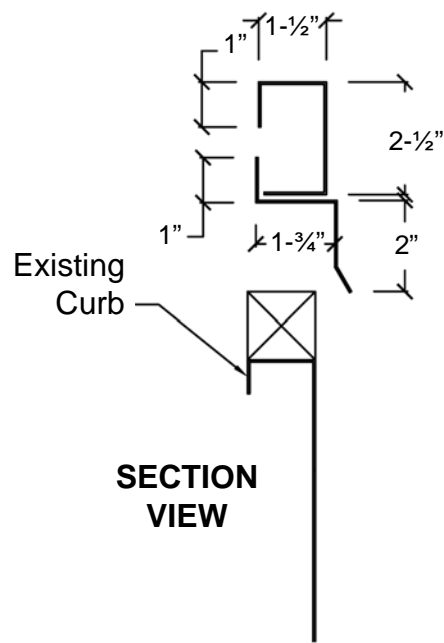
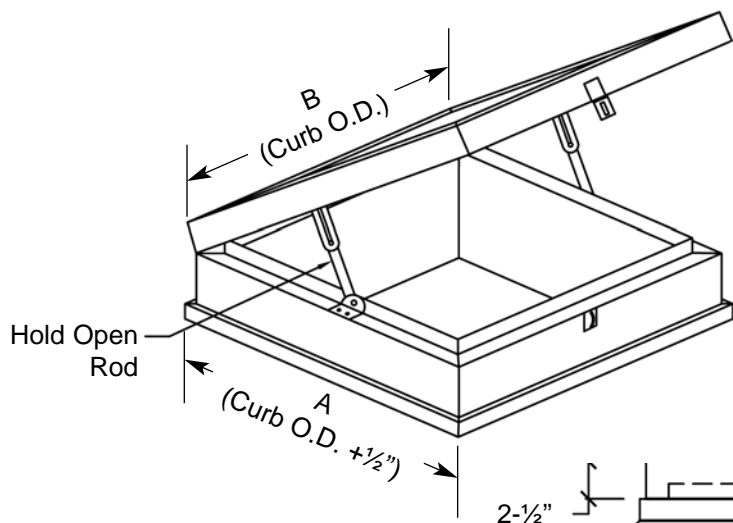

▼ Hinged Curb Adapter for Canted Curbs (Models JCEA and JCPA) — Model VXPC

Standard Construction:

- 20" and under = 18 gauge Galvanized Steel
- 20-1/2" through 30-1/2" = 16 gauge Galvanized Steel
- Above 30-1/2" = 14 gauge Galvanized Steel

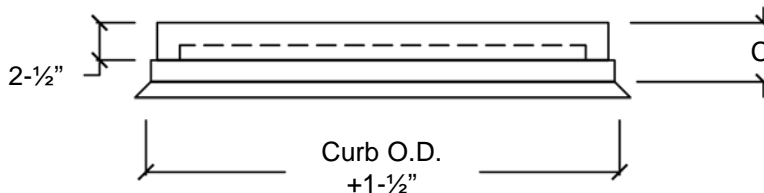
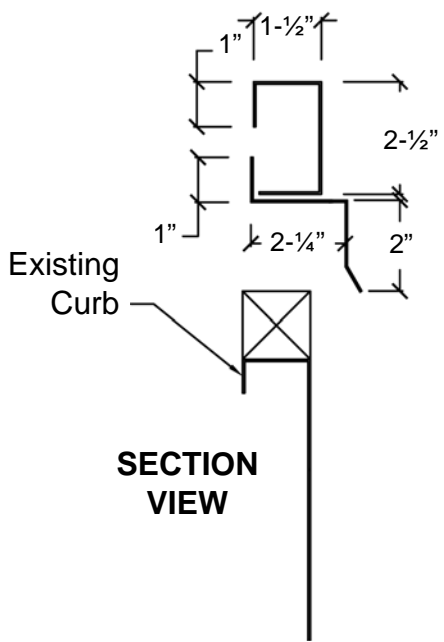
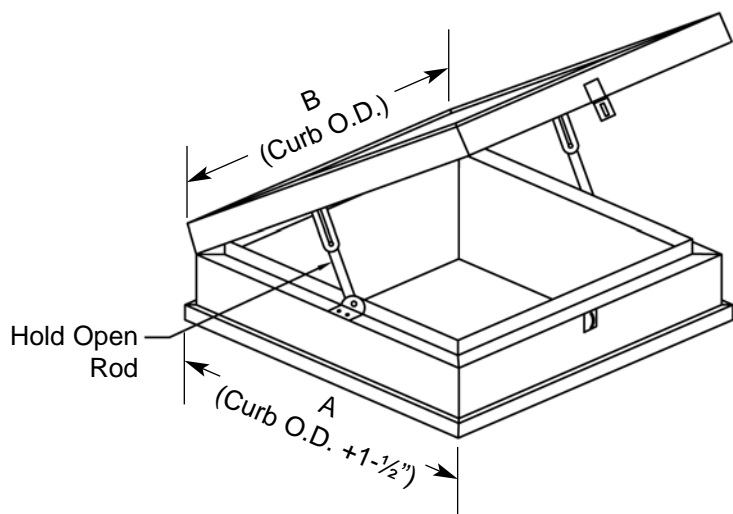

▼ Galvanized Curb Cap Adapter — Model JCAAG

Standard Construction:

Base I.D. through 43" = 18 gauge Galvanized Construction
 Base I.D. 43-1/2" through 63" = 16 gauge Galvanized Construction
 Base I.D. above 63" = 14 gauge Galvanized Construction
Features internal angle reinforcing with welded corners.

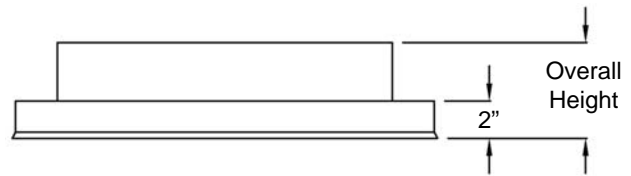
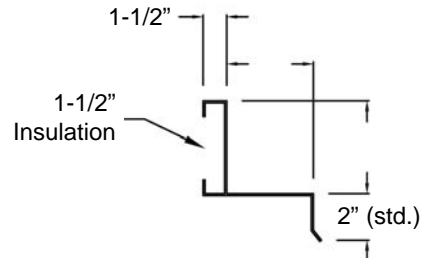
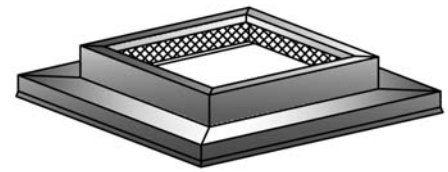
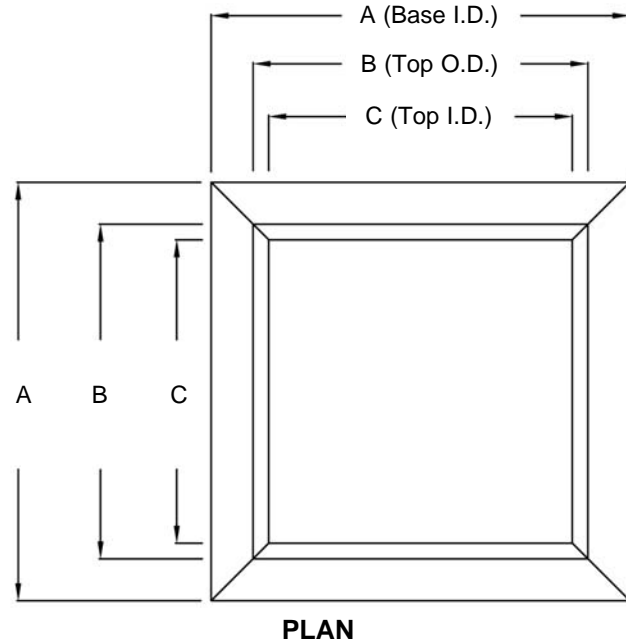

Adapter Dimensions:

A = Old Curb Cap Dimensions
 B = New Curb Cap Dimensions
 C = B - 3"

▼ Aluminum Curb Cap Adapter — Model JCAAA

Standard Construction:

Base I.D. through 63" = .063 Aluminum Construction
 Base I.D. above 63" = .090 Aluminum Construction
Features internal angle reinforcing with welded corners.

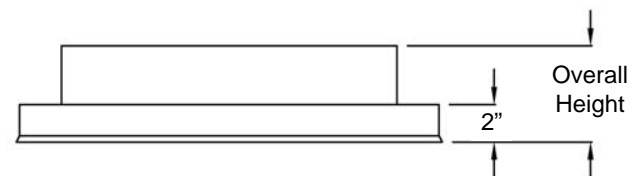
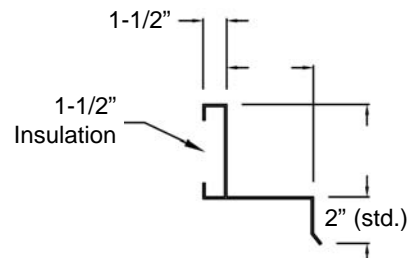
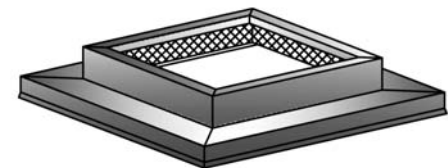
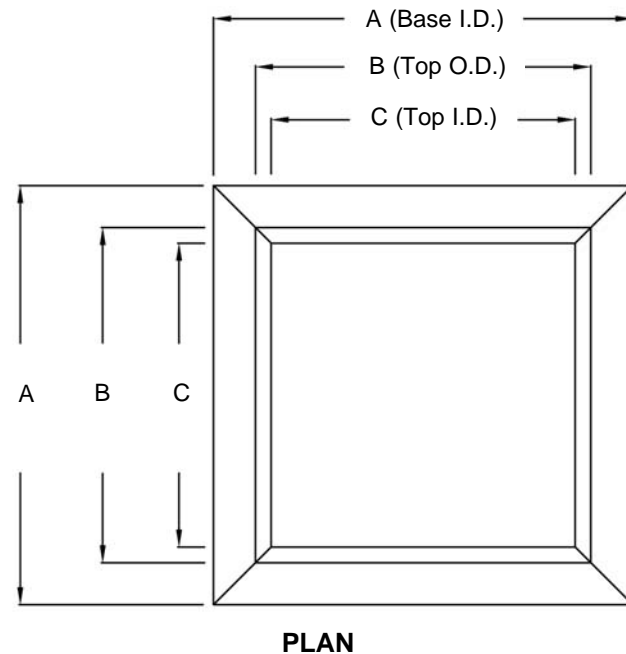

Adapter Dimensions:

A = Old Curb Cap Dimensions
 B = New Curb Cap Dimensions
 C = B - 3"

▼ Solid State Speed Controls for Ventilators — Models JXUA, JXVA and JXWA

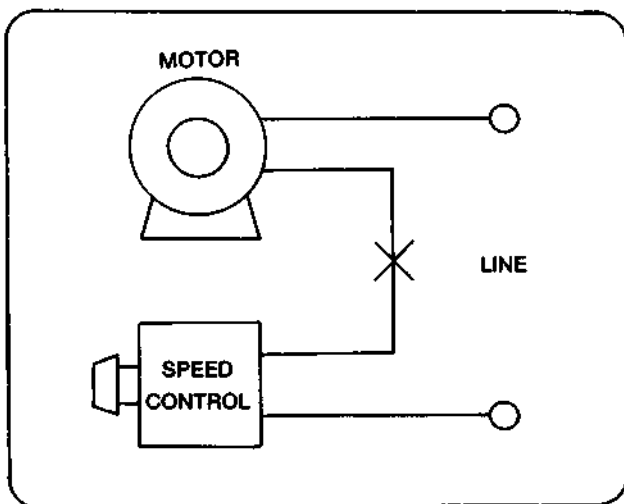
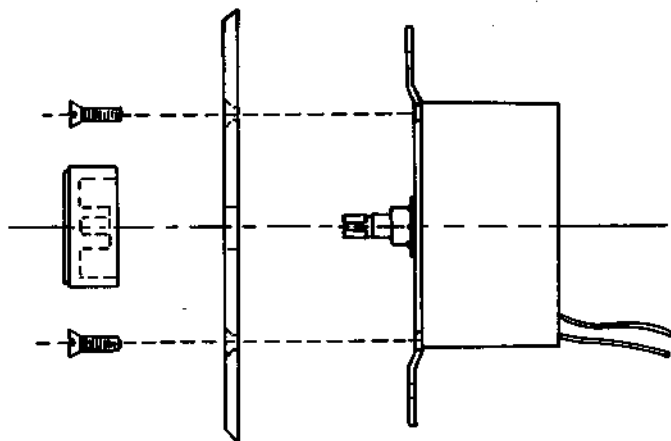

- Models:**
 VEDK
 VUDK
 VIDK
 VCDK
 VLDK/VTDK
 VWDK
 LYDK

NOTE: For use with 115/1 ODP motors only.

- JXUA** 120 Volt AC, 60 Cycle, 3 Amp. maximum.
- JXVA** 120 Volt AC, 60 Cycle, 6 Amp. maximum.
- JXWA** 120 Volt AC, 60 Cycle, 10 Amp. maximum.

Application: 1) Motor Type - Shaded Pole, P. S. C., and Universal.
 2) Required Load - Fans, Blowers, and speed dependent loads.

Wiring - Connect control in series with motor and line voltage; never connect control across line. Leads: 2

Mounting: 1) Use 2" deep standard Gem Box.
 2) Secure control with outer bracket tabs.

Minimum speed adjustment is factory set.
 Face plate is anodized aluminum.

CAUTION: DO NOT OPERATE FAN BELOW MINIMUM CATALOG RPM!

▼ 115 Volt Thermostat with Coiled Capillary Tube — Model JTCA

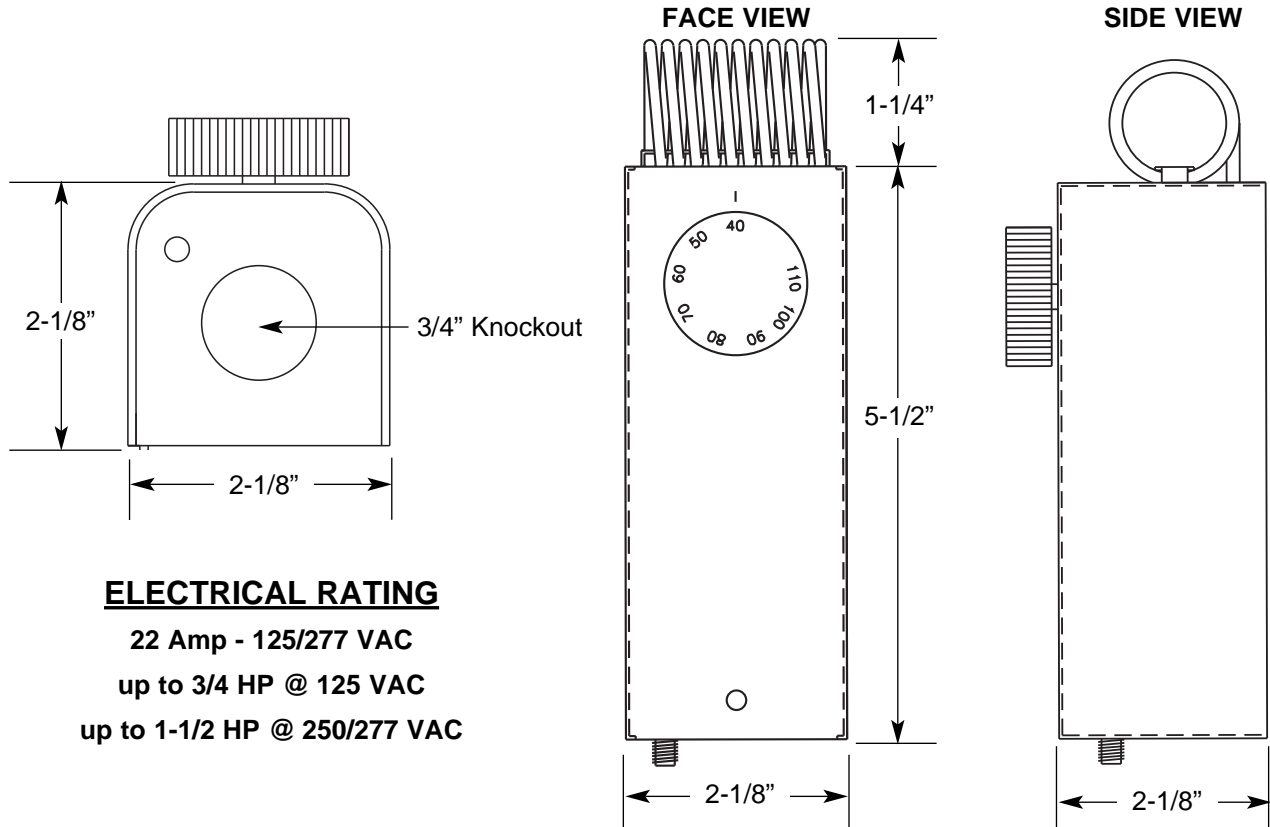

▼ 115 Volt Thermostat with Capillary Tube — Model JTDA

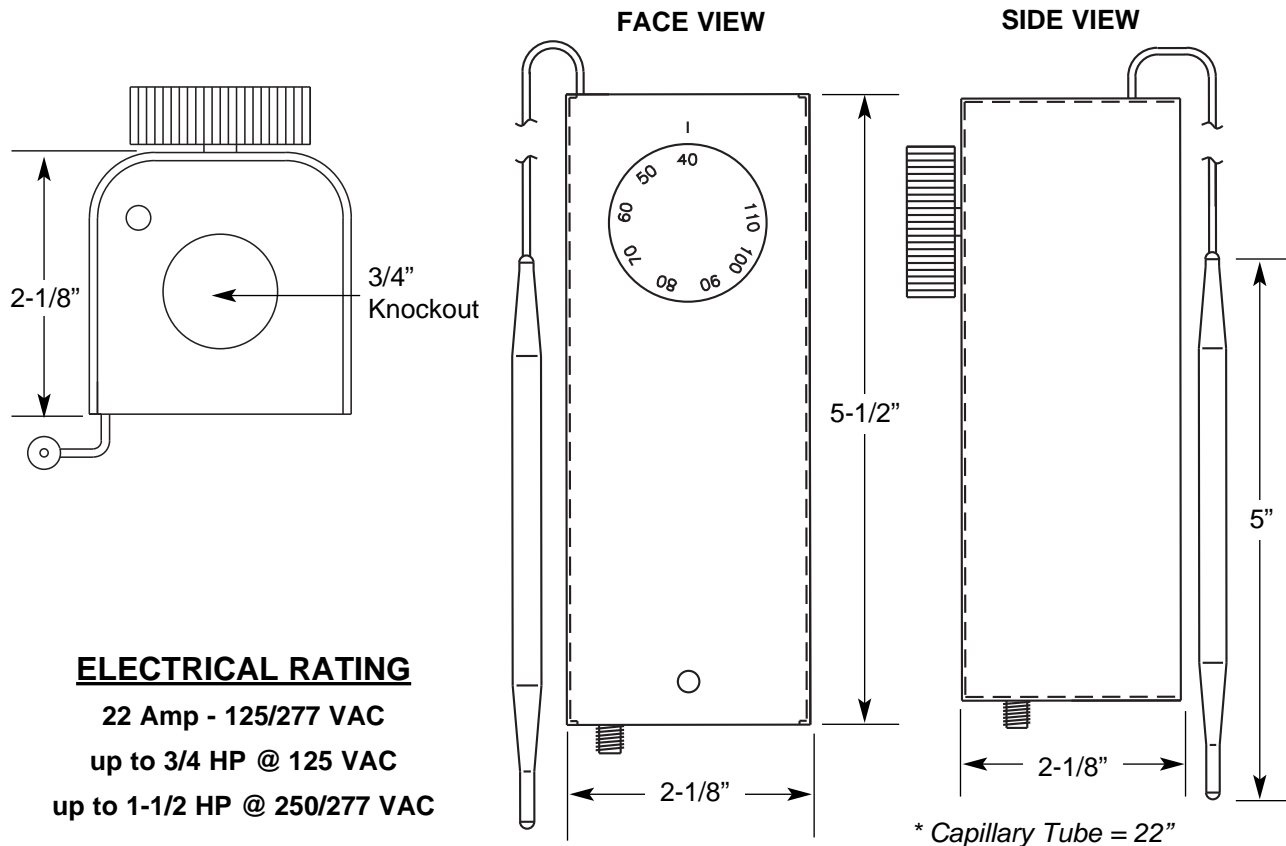

▼ VW Wall Grille — Model VXWAG

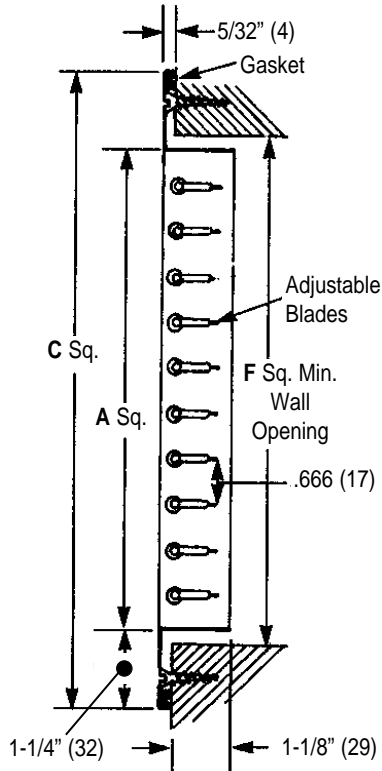

Models:
VWDK/VWBK

MODEL VXWAG

Cold Roll Steel
with Carnes Gray
Electrocoat
Paint (04)

Cold Roll Steel
with Carnes White
Electrocoat
Paint (01)

VXWAG UNIT SIZE	GRILLE SIZE	DIMENSIONS		
		A	F	C
06	12	11-1/2 (292)	12 (305)	14 (356)
08	12	11-1/2 (292)	12 (305)	14 (356)
10	14	13-1/2 (343)	14 (356)	16 (406)
12	14	13-1/2 (343)	14 (356)	16 (406)
15	17	16-1/2 (420)	17 (432)	19 (483)
18	22	21-1/2 (546)	22 (559)	24 (610)
21	25	24-1/2 (622)	25 (635)	27 (686)
24	28	30-1/2 (775)	28 (711)	30 (762)

Dimensions are listed in inches - Metric are listed in millimeters (mm).

▼ Flow Control Plate — Model VXFA
For Use With K-Series Ventilators

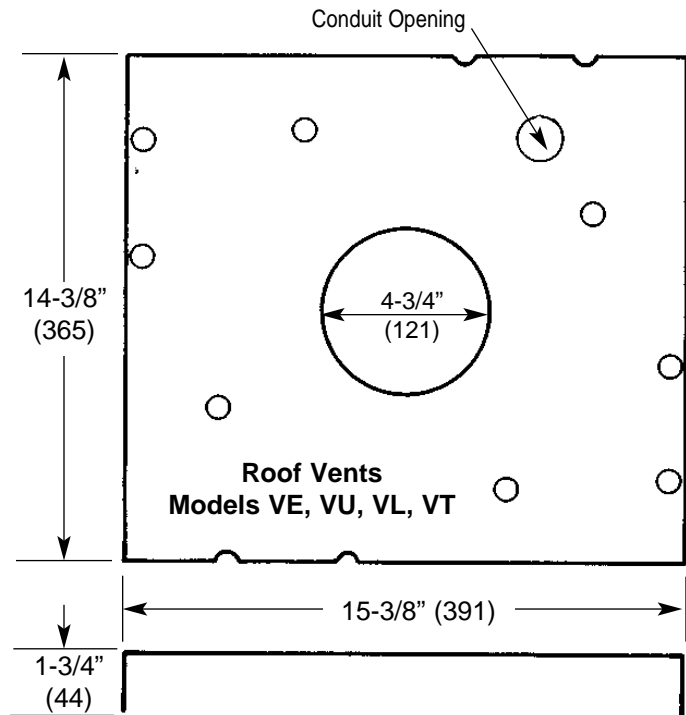
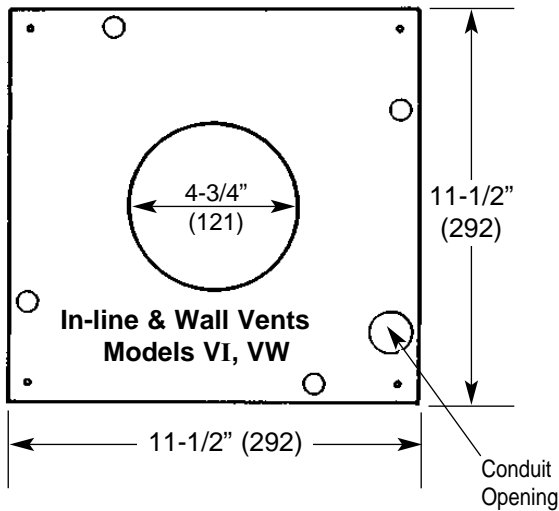

MODEL VXFAV

- Vertical mount.
- .063 aluminum.
- Mill finish.
- Mounts to inlet venturi:
Utilizes existing fasteners on in-line duct fans.
Self-tapping screws supplied for attachment to wall vents.

MODEL VXFAH

- Horizontal mount.
- .063 aluminum.
- Mill finish.
- Mounts between roof curb and ventilator. Held in position when vent is secured to roof curb.

▼ Neoprene Hanging Isolator for Use With VI - Sizes 6 thru 18 and VCDD Ceiling Fans - All Sizes — Model VXIAHE

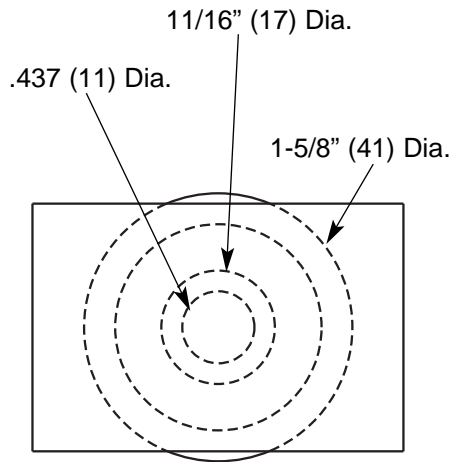
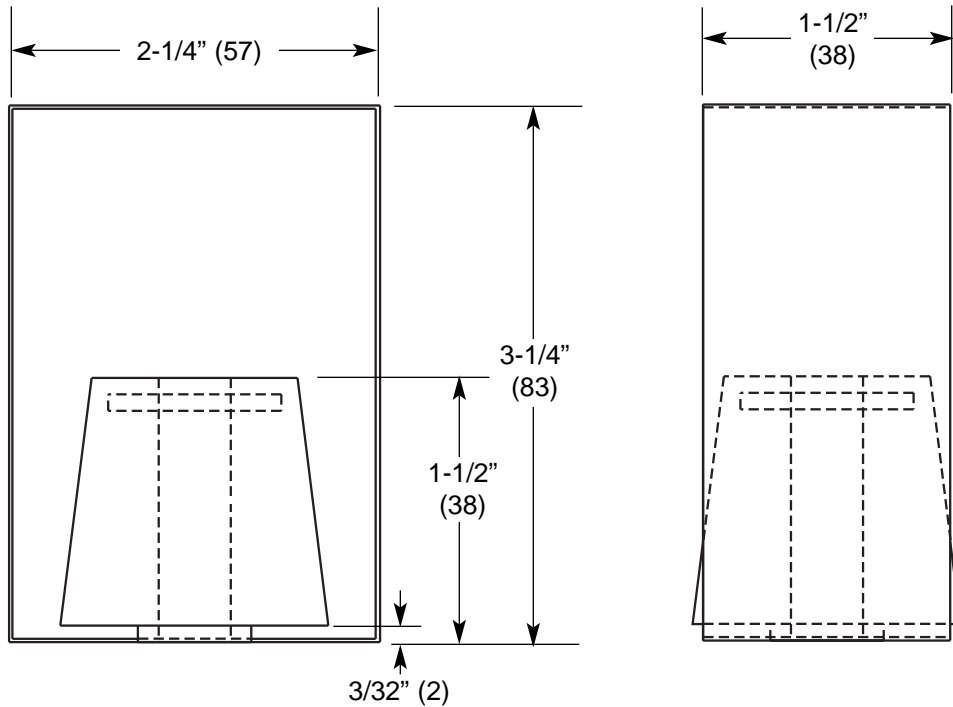

Models:
VIBK/VIDK
VCDD

Average Durometer reading = 48

Deflection in Inches	Force in Pounds
0.000	0.000
0.025	8.030
0.050	18.830
0.075	27.850
0.100	38.700
0.200	75.700
0.250	93.000
0.500	162.150

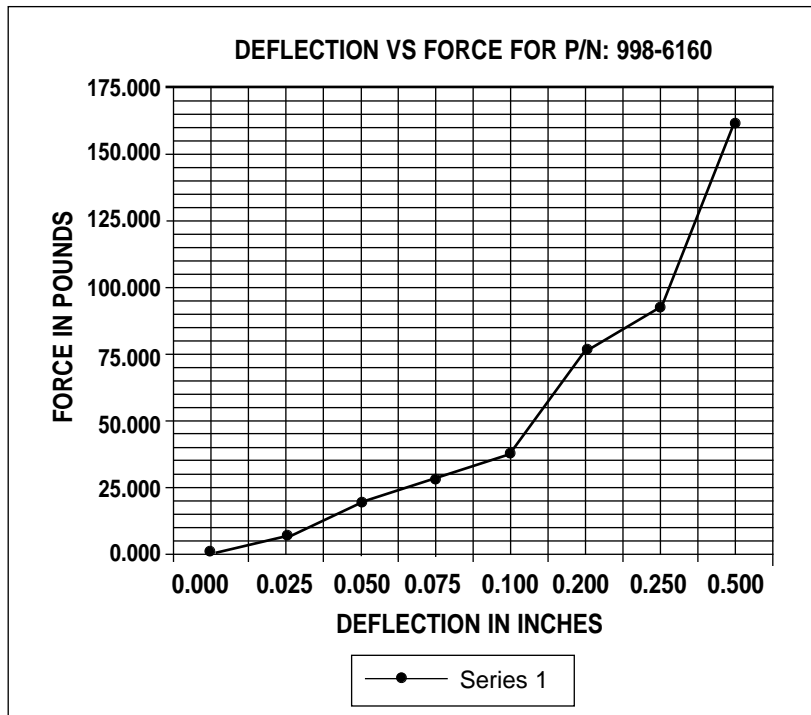

▼ Spring Hanging Isolator — Model VXIAHG - VIBK Sizes 21 thru 24
 — Model VXIAHJ - VIBK Sizes 30 thru 42

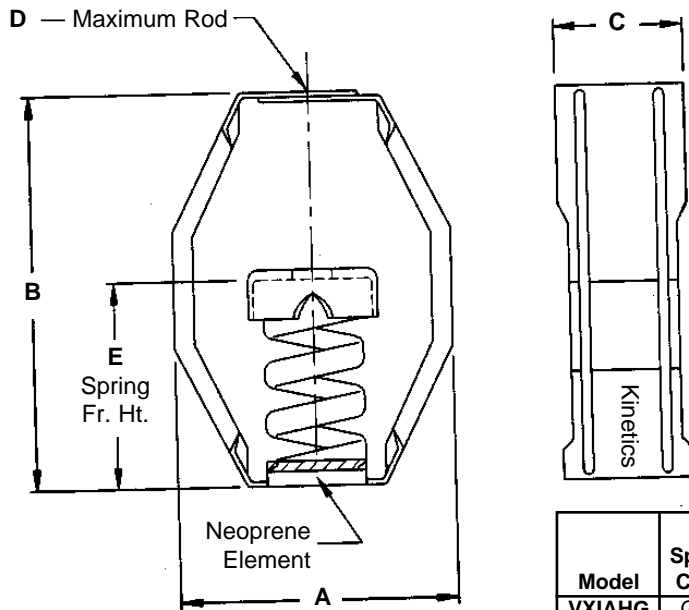

NOTES:

1. Isolation hangers have a minimum Kx/Ky of 1.0.
2. Spring Elements are safe for solid loading.
3. Hanger brackets will carry (5) times overload without failure.
4. Hanger brackets will allow 30° rod misalignment without short circuiting.
5. Spring elements and brackets are power coated. Load plates are bright zinc plated.

Models:
VIBK Only

Model	Spring Color	Rated Load (Lbs.)	Rated Deflection	Dimensions Listed In Inches				
				A	B	C	D	E
VXIAHG	Gray	125	1.25	3.69	5.25	2.25	.50	3.00
VXIAHJ	Brown	245	1.19	3.69	5.25	2.25	.50	3.00

▼ Floor Mounted Vibration Isolator for VIBK/VIDK Sizes 6 thru 42 — Model VXIA

Concentric Raised Ring
1.07 O.D. x .96 I.D. x 0.3 H

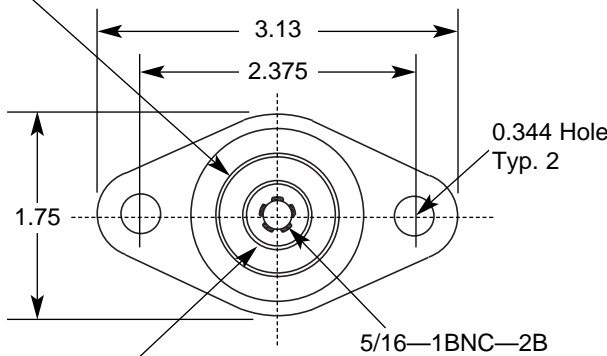

Concentric Raised Ring
.60 O.D. x .49 I.D. x 0.3 H

PLAN

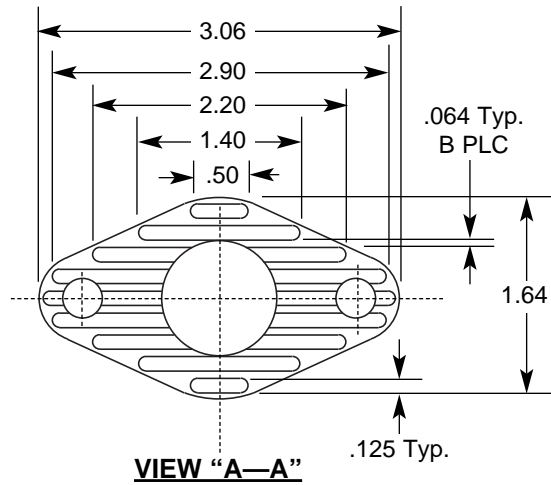

VIEW "A-A"

Models:
VIBK/VIDK

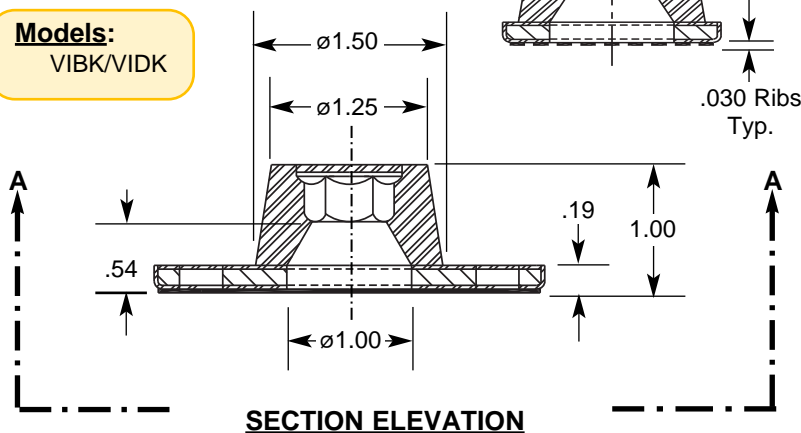

SECTION ELEVATION

Color: Black
 Durometer: 65—75
 Material: Neoprene
 Tensile Strength: 250 Lbs. (Min.)

COMPRESSION	
FORCE	MAX. DEFLECTION
90 Lbs.	.1 In.
120 Lbs.	.14 In.
150 Lbs.	.16 In.
175 Lbs.	.18 In.

▼ Grease Trough — Model VXUAG

For Use with Model VRBK
Restaurant Exhaust Fans

STANDARD FEATURES:

- .063 (1.6) aluminum.
- Hinged cover.
- Welded, watertight corners.
- Mounts to curb cap, under drain opening.
- Ships loose.

Models:
VRBK

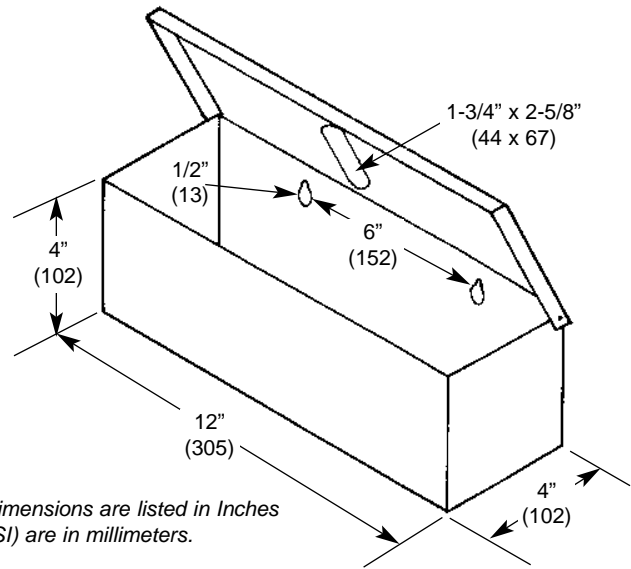

All Imperial [IP] dimensions are listed in Inches
Metric (SI) are in millimeters.

▼ Centrifugal Upblast Roof Exhausters for Commercial Kitchen Applications — Model VRBK - Belt Drive

Models:
VRBK

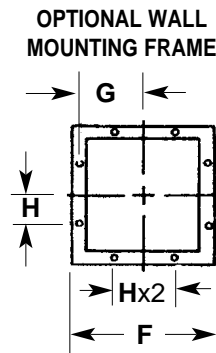

Optional Wall Mounting Frame				
Opening Sq.	O. D. F	Typical G	Typical H	Wall Mtg. Frame 1-1/2 x 1-1/2 [Steel Angle]
12	15-3/8	6-15/16	4-11/16	16 ga.
12	15-3/8	6-15/16	4-11/16	16 ga.
14	17-1/2	8	5-3/4	16 ga.
14	17-1/2	8	5-3/4	16 ga.
17	20-3/8	9-7/16	7-3/16	16 ga.
22	24-7/8	11-11/16	7-7/16	16 ga.
25	28	13-1/4	9	16 ga.
28	31	14-3/4	10-1/2	16 ga.

▼ Wall Frame — Models VWDK and VWBK

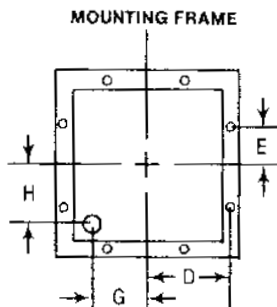

Unit Size	Dimensions In Inches					
	Mounting Frame 1-1/2 x 1-1/2 Angle			Wall Opening Sq. F	Conduit Location	
	OD Sq.	D	E		G	H
06	15-3/8	6-15/16	4-11/16	12	3-3/4	5
08	15-3/8	6-15/16	4-11/16	12	3-3/4	5
10	17-1/2	8	5-3/4	14	5-3/8	5-3/8
12	17-1/2	8	5-3/4	14	5-3/8	5-3/8
15	20-3/8	9-7/16	7-3/16	17	6-7/8	5-7/8
18	24-7/8	11-11/16	7-7/16	22	9-5/16	7-11/16

▼ Automatic Belt Tensioner for Single V-Belt Units Only — Models VEBK, VUBK, VWBK and VRBK

Sizes 6 to 18

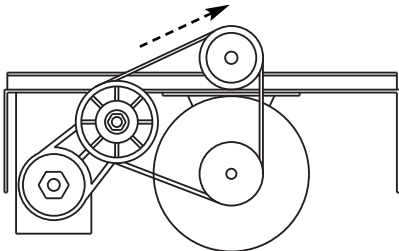

Unit Size	*Selected HP Range
6	1/6 - 1/2
8	1/6 - 1/2
10	1/6 - 3/4
12	1/6 - 3/4
15	1/6 - 2
18	1/6 - 3

*Automatic Belt Tensioner
Not Available on Larger HP.

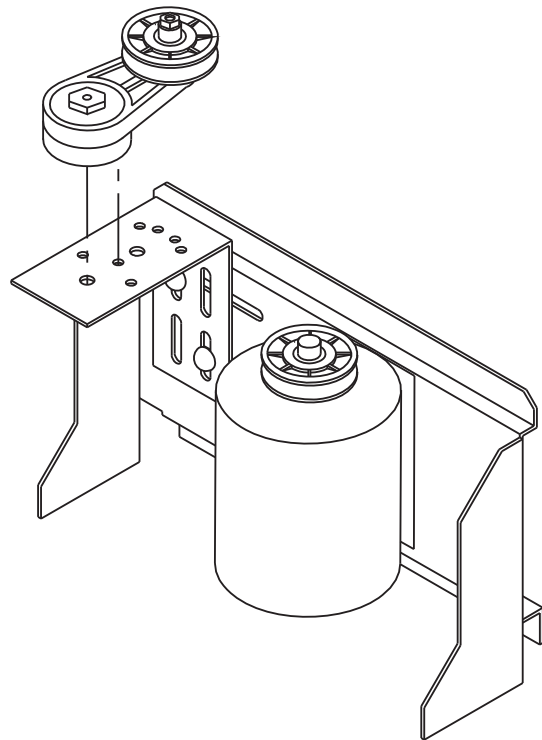

▼ Automatic Belt Tensioner for Single V-Belt Units Only — Models VEBK, VUBK, VWBK and VRBK

Sizes 21 & 24

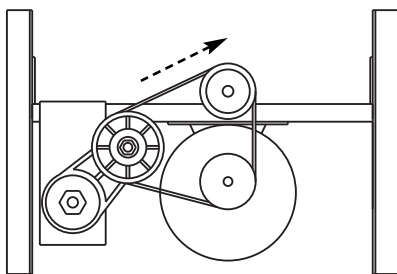

Unit Size	*Selected HP Range
21	1/4 - 3
24	1/3 - 3

*Automatic Belt Tensioner
Not Available on Larger HP.

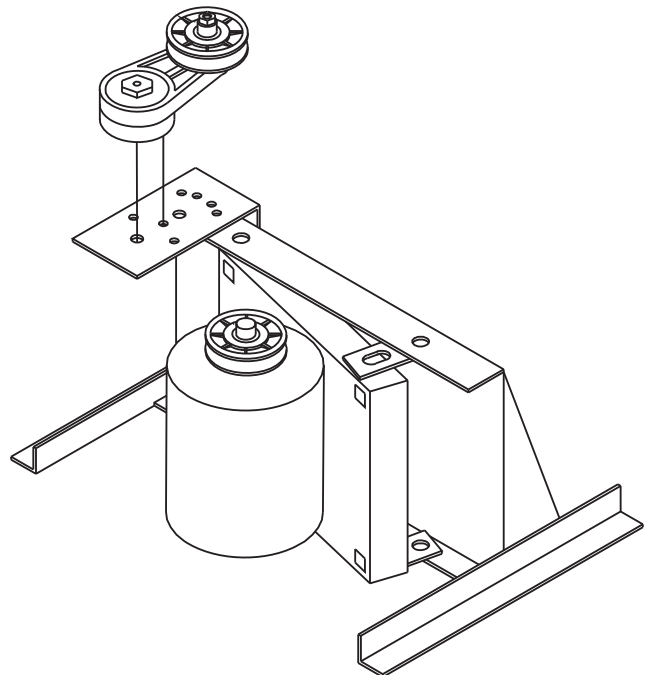

▼ Horizontal or Vertical Exhaust Damper — Model JDHAA - Automatic/Gravity
 — Model JDHAM - Motorized
 — Model JDHAC - Chain Operated

- Models:**
 VEDK/VEBK
 VUDK/VUBK
 VWDK/VWBK
 VIDK/VIBK
 VTDK/VTBK
 VLDK/VTBK
 Gravity Hoods

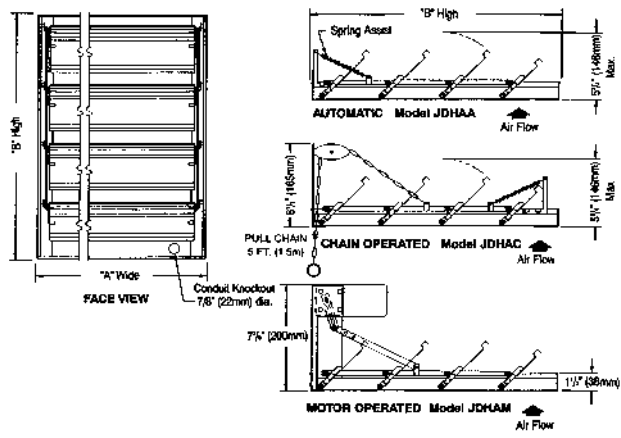

STANDARD SPECIFICATIONS

- Max. Velocity: 1500 FPM (8 M/S)
- Max. Differential Pressure: 1" W.G. (250 N/M²)
- Max. Temperature: Damper 250°F (95°C)
Motor 130°F (55°C)
- Frame: .063" (1.6mm) 6063T6 Aluminum.
- Blades: 24 ga. aluminum with double stiffening breaks.
- Bearings: Self lubricating nylon.
- Blade Pivots: 3/16" (5mm) plated steel.
- Blade Linkage: Galvanized steel. Double linkage for width exceeding 20" (508mm).
- Seals: Felt between blades and polyurethane sponge at sill.
- Maximum single piece panel size: 50" width x 72" height (1270mm x 1829mm).
- Finish: Mill aluminum.

SPRING ASSIST IS FIELD INSTALLED AND IS RECOMMENDED FOR FACE VELOCITY LESS THAN 600 FPM

▼ Horizontal Intake Damper — Model JDTAA - Automatic
 — Model JD TAM - Motorized
 — Model JD TAC - Chain Operated

Model JD TAA - Automatic

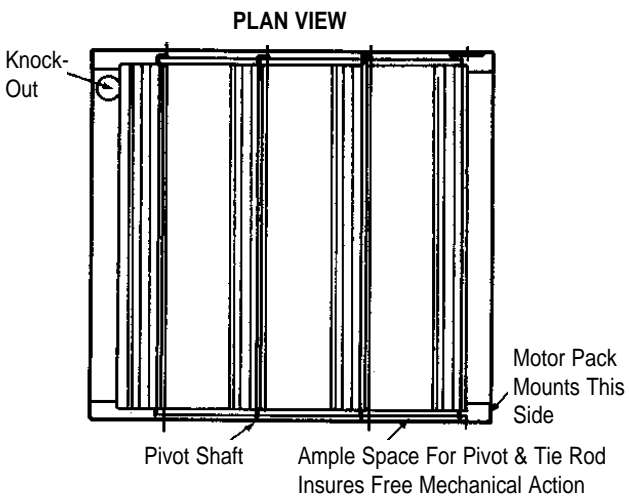

Model JD TAM - Motorized

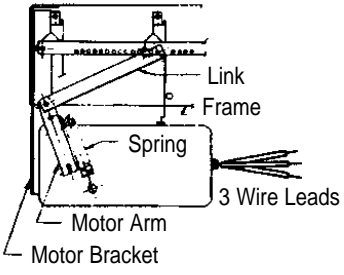

- Continuous stall type electric motor (11 watts); single phase, 115 or 230 volts.
- Motor pack shipped separately for field mounting.
- Separate transformer supplied for 360 or 560 volt motor pack. Requires field mounting and wiring.

Model JD TAC - Chain Operated

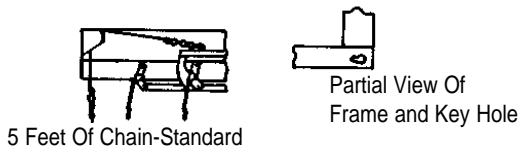

STANDARD FEATURES:

- Bronze bearings.
- Spring return.
- Aluminum blades with felt edges.
- 19 gauge CRS frame with zinc chromate prime coat.
- Dampers larger than size 500 are shipped in two or more pieces.
- Damper undersized 1/4" from nominal except when fractional dimension is specified.

- Models:**
 Gravity Hoods

▼ Duct Adapter — Model VXGA - Curb Mounted Damper
 — Model VXHA Duct Mounted Damper

Models:

VHBB
 VSBB

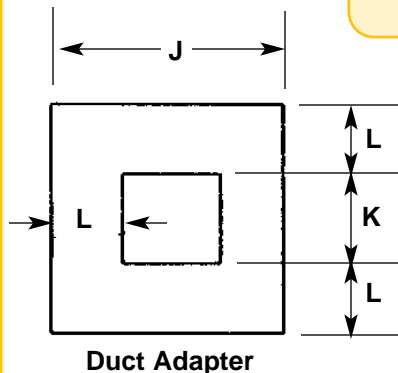

Duct Adapter

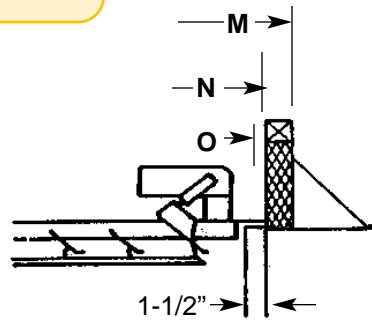

Model VXGA
Curb Mounted Damper
 [Requires 1-1/2" damper shelf]
 Shown with optional motor pack

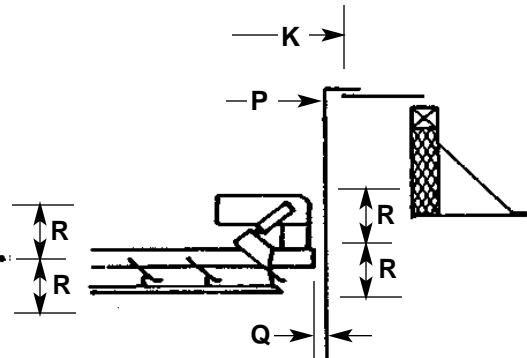

Model VXHA
Duct Mounted Damper
 Shown with optional motor pack

DIMENSIONS LISTED IN INCHES												
Unit Size	J Sq.	K Sq.	L	Roof Curb Sq.		VXGA Damper		P Duct Sq. I. D.	VXHA Damper		R Damper Clearance	1" Filters Qty. - Nom. Size
				M O.D.	N I.D.	Size	O Sq. O.D.		Size	Q Sq. O.D.		
08	18	12-1/4	2-7/8	18-1/2	15-1/2	15	14-3/4	12	12	11-3/4	7	4 - 10x16
10	26-1/2	14-1/4	6-1/8	27	24	23	22-3/4	14	14	13-3/4	7	4 - 16x25
12	26-1/2	18-1/4	4-1/8	27	24	23	22-3/4	18	18	17-3/4	7	4 - 16x25
15	30	20-1/4	4-7/8	30-1/2	27-1/2	27	26-3/4	20	20	19-3/4	7	4 - 16x25
18	34	26-1/4	3-7/8	34-1/2	31-1/2	31	30-3/4	26	26	25-3/4	7	4 - 20x25
20	48-1/2	30-1/4	9-1/8	49	46	45	44-3/4	30	30	29-3/4	7	8 - 20x20

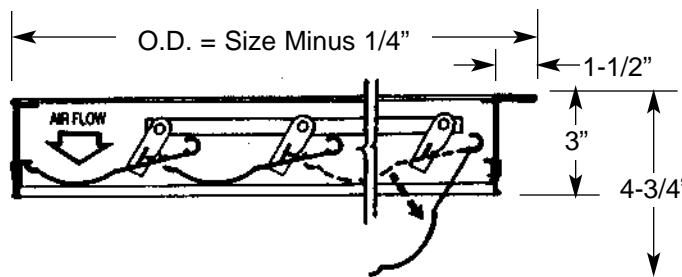

DAMPER SPECIFICATIONS

- FRAME: .050", 16 Ga. 6063-T5 ALUMINUM.
- BLADES: .050", 16 Ga. 6063-T5 ALUMINUM.
- SEALS: HEAVY DUTY VINYL.
- MAXIMUM VELOCITY: 2500 Ft./Min.
- MAXIMUM PRESSURE DIFFERENTIAL: 1" W.G.
- FINISH: MILL.
- MAXIMUM PANEL SIZE: 36" W x 48" L.
- COUNTER BALANCED FOR INTAKE
- HEAVY DUTY BLADE LINKAGE
- CONDUIT HOLE (1") FOR MOTOR PACK WIRING.

- VXGAA** = FLANGED FRAME — GRAVITY OPERATED
- VXGAM** = FLANGED FRAME — MOTOR OPERATED
- VXHAA** = CHANNEL FRAME — GRAVITY OPERATED
- VXHAM** = CHANNEL FRAME — MOTOR OPERATED

MOTOR OPERATOR

- Power Open / Spring Close [PO / SC].
- 115-230/1/60 Continuous Stall Type.
- Motor and Hardware Are Field Installed.
- Transformer [Optional] for 460 or 575 Volts.

	115 V	230 V
IDLE SPEED	1.8 RPM	1.8 RPM
IDLE AMPS	0.24	0.13
STALL AMPS	0.26	0.14

▼ Propeller Fan Accessory - Backdraft Damper

- Model LXHAA - Horizontal Roof Exhaust (Automatic)
- Model LXHAM - Horizontal Roof Exhaust (Motorized)

Models:
VHBB
VSBB

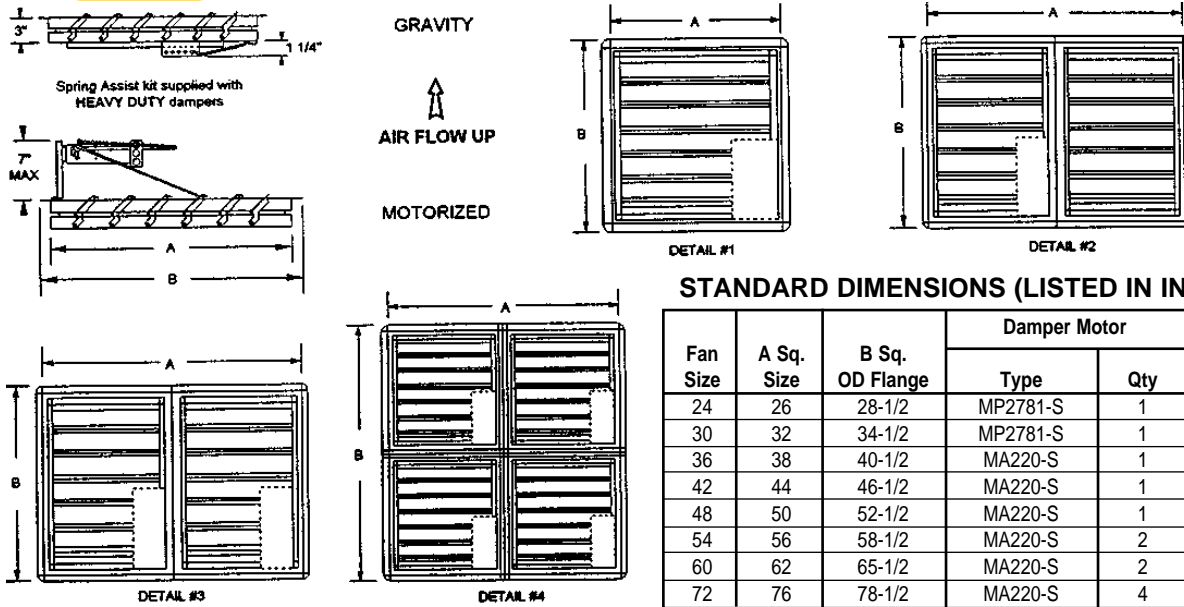

STANDARD DIMENSIONS (LISTED IN INCHES)

Fan Size	A Sq. Size	B Sq. OD Flange	Damper Motor		Panels (Detail)
			Type	Qty	
24	26	28-1/2	MP2781-S	1	1
30	32	34-1/2	MP2781-S	1	1
36	38	40-1/2	MA220-S	1	1
42	44	46-1/2	MA220-S	1	2
48	50	52-1/2	MA220-S	1	2
54	56	58-1/2	MA220-S	2	3
60	62	65-1/2	MA220-S	2	3
72	76	78-1/2	MA220-S	4	4

Heavy Duty Dampers required on all units with 7-1/2 HP motors and above.

▼ LF/LG Roof Supply Propeller Fan Accessory

- Model LXTAA - Roof Supply (Automatic)
- Model LXHAM - Roof Supply (Motorized)

Models:
LFDA/LFBA
LGDA/LGBA

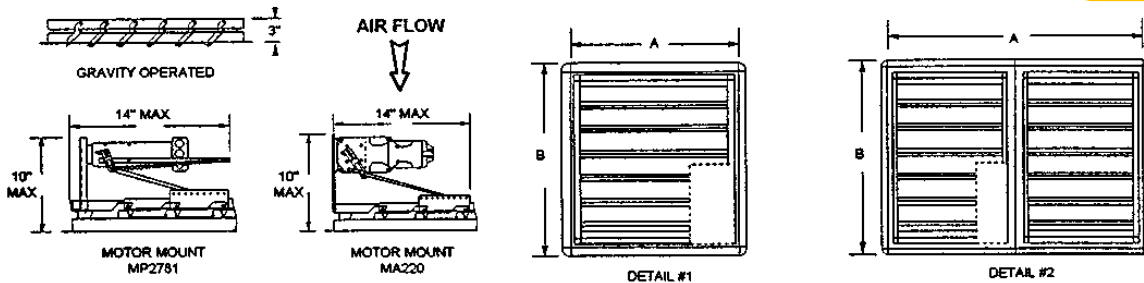

NOTE
Counter balance weight kits are required on all supply dampers (gravity or motor operated)

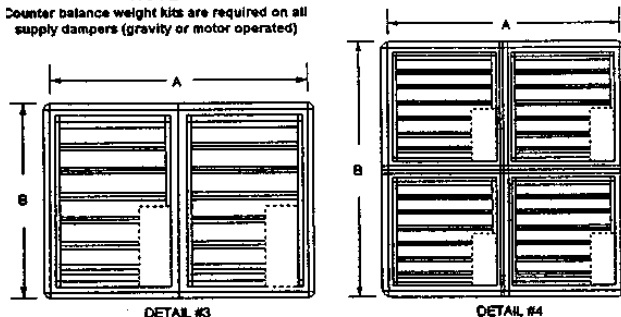

STANDARD DIMENSIONS (LISTED IN INCHES)

Fan Size	A Sq. Size	B Sq. OD Flange	Motor Type		Panels (Detail)
			Type	Qty	
24	26	28-1/2	MP2781	1	1
30	32	34-1/2	MP2781	1	1
36	38	40-1/2	MP2781	1	1
42	44	48-1/2	MA220	1	2
48	50	52-1/2	MA220	1	2
54	56	58-1/2	MA220	1	2
60	62	65-1/2	MA220	1	2
72	76	78-1/2	MP2781	4	4

Heavy Duty Dampers required on all units with 7-1/2 HP motors and above.

▼ Propeller Fan Accessory - End Pivot Vertical Backdraft Damper

Models:

- LWBK/LMBK
- LRBK/LNBK

- Model LXVBA - Exhaust (Gravity)
- Model LXVBM - Exhaust (Motorized)
- Model LXXBA - Supply (Gravity)
- Model LXXBM - Supply (Motorized)

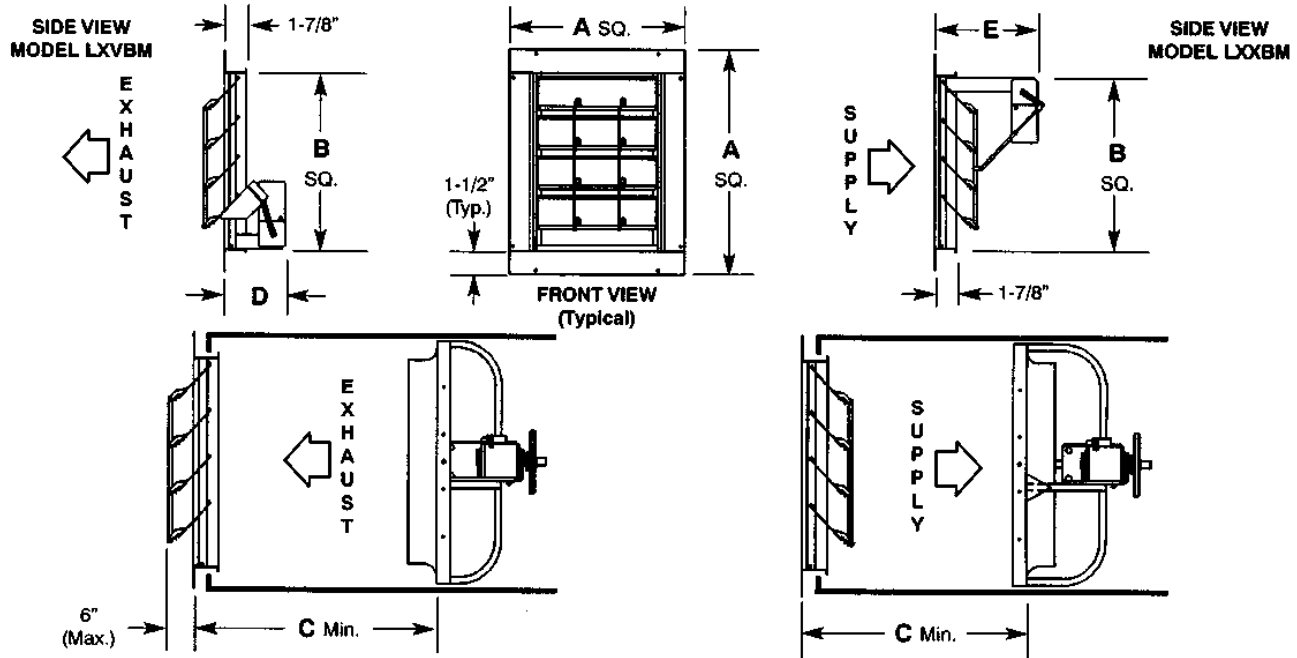

DIMENSIONS LISTED IN INCHES						
Fan Size	A Sq.	B Sq.	C ⁽¹⁾ Min.	D (Exh.)	E (Sup.)	Weight (Lbs.)
20	24	21-3/4	12-1/2	5-1/2	9-1/2	8
24	28	25-3/4	12-1/2	5-1/2	9-1/2	11
30	34	31-3/4	15-1/2	5-1/2	9-1/2	17
36	40	37-3/4	17-1/2	5-1/2	9-1/2	17
42 ⁽²⁾	46	43-3/4	19-3/4	7	10	32
48 ⁽²⁾	52	49-3/4	21-3/4	7	10	42

- (1) Minimum clearance from propeller fan to damper. Decreased clearance can damage damper or fan and will void warranty.
- (2) Two panels wide (Factory joined sections) requires Carnes Motor Kit specifically designed multi-panel for multi-panel shutters.

MOTOR CHARACTERISTICS		
	120V	240V
Idle Speed (RPM)	1.8	1.8
Idle Amps	0.244	0.137
Stall Amps	0.261	0.146

Motor kits ship loose for field installation.

- POSC (Power Open-Spring Close)
- Standard Motor Voltage is 115-230/1/60.
- Optional 24 VAC or 575 VAC.
- Optional Transformer _____ VAC / _____ VAC.

Motor kit weight - 5lbs.

CAUTION: Motor Kits are not suitable for use in atmospheres or air flows containing explosive or flammable products.

STANDARD SPECIFICATIONS AND CONSTRUCTION

- Frame:** 063" 6063-T6 Aluminum recesses the damper into opening.
- Blades:** 22 ga. (sizes 30" wide and larger) 24 ga. (sizes smaller than 30" wide).
- Axles:** 3/16" diameter full length plated steel rod.
- Linkage:** Double blade linkage with aluminum linkage bars.
- Seals:** Polyethylene on sill and felt seals between blades.

- Operator:** Electric - power open spring close (POSC) ship loose for field installation. Standard voltage is 115-230/1/60 with optional 24/1/60 or 460/1/60 available.
- Max. Velocity:** 2500 ft./min. face velocity maximum.
- Max. Pressure:** 1" w.g. differential pressure maximum.
- Max. Temperature:** 200°F without electrical operator. 120°F with operator.

▼ Propeller Fan Accessories - Damper Guard with Birdscreen Wire Guard
— Model LXMBP

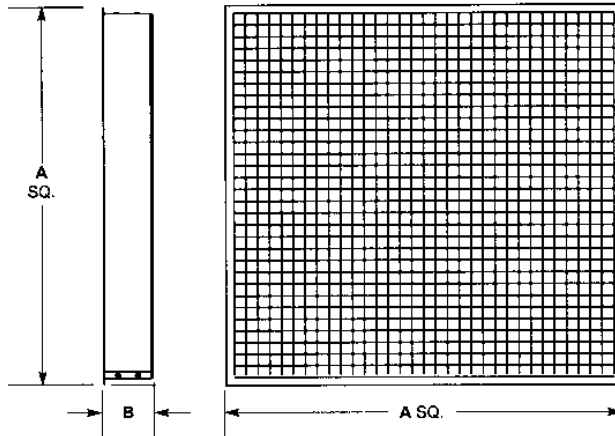

FINISHES:

Gray Electrocoat as standard.

OPTIONAL FINISHES:

- Air Dry Enamel to match.
- Acid Resistant Coating (ARC, Epoxy).
- Air Dry Heresite.

Models:
LWBK/LMBK
LRBK/LNBK

UNIT	UNIT DIMENSION							
	20	24	30	36	42	48	54	60
A Sq.	24-1/2" (623)	28-1/2" (724)	34-1/2" (877)	40-1/2" (1029)	46-1/2" (1181)	52-1/2" (1334)	58-1/2" (1486)	64-1/2" (1638)
B	7" (178)	7" (178)	7" (178)	7" (178)	7" (178)	7" (178)	7" (178)	7" (178)
Gauge	18 galv.	18 galv.	18 galv.	18 galv.	18 galv.	18 galv.	18 galv.	18 galv.
Wt. Lbs. (Kg.)	16 (7.2)	18 (8.2)	22 (10)	26 (11.8)	30 (13.6)	34 (15.5)	39 (17.7)	42 (19.1)

NOTE: Damper guard may not be used with weatherhood.

▼ Propeller Fan Accessories - Damper Guard with OSHA Guard
— Model LXMBN

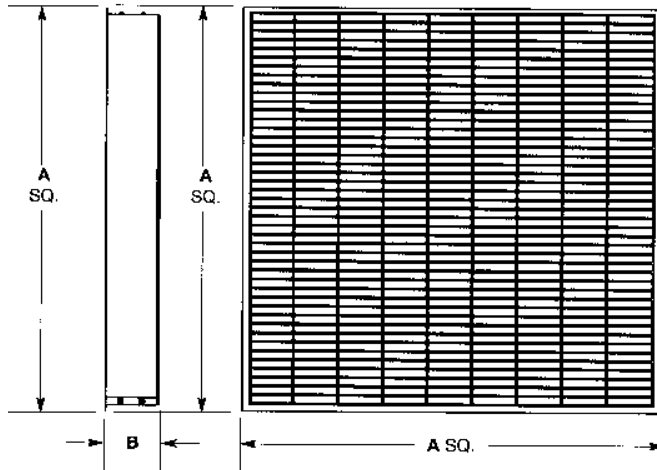

LOUVER EXTENSION:

FINISHES:

Gray Electrocoat as standard.

OPTIONAL FINISHES:

- Air Dry Enamel to match.
- Acid Resistant coating (ARC, Epoxy).
- Air Dry Heresite.

Models:
LWBK/LMBK
LRBK/LNBK

UNIT	DIMENSIONS and WEIGHT							
	20	24	30	36	42	48	54	60
A Sq.	26-1/2" (673)	28-1/2" (724)	34-1/2" (877)	40-1/2" (1029)	46-1/2" (1181)	52-1/2" (1334)	58-1/2" (1486)	64-1/2" (1638)
B	7" (178)	7" (178)	7" (178)	7" (178)	7" (178)	7" (178)	7" (178)	7" (178)
Gauge	18 galv.	18 galv.	18 galv.	18 galv.	18 galv.	18 galv.	18 galv.	18 galv.
Wt. Lbs. (Kg.)	20 (9.1)	24 (10.9)	30 (13.6)	38 (17.3)	45 (20.5)	54 (24.5)	64 (29.1)	73 (33.2)

NOTE: Damper guard may not be used with weatherhood.

▼ Propeller Fan Accessories - Flat OSHA Guard (Non-Hinged) — Model LXMBB

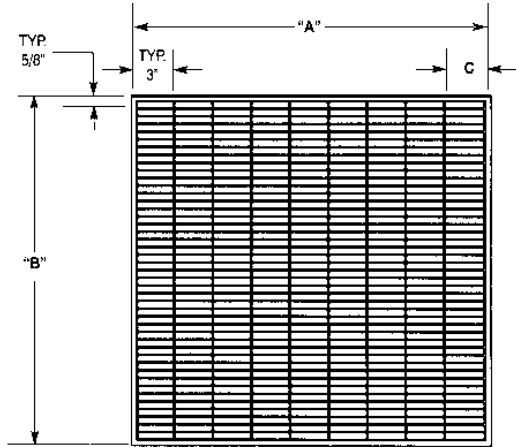

UNIT	DIMENSIONS and WEIGHT							
	20	24	30	36	42	48	54	60
A	24-1/2"	28-1/2"	34-1/2"	40-1/2"	46-1/2"	52-1/2"	58-1/2"	64-1/2"
Sq.	(623)	(724)	(877)	(1029)	(1181)	(1334)	(1486)	(1638)
B	24-3/8"	28-1/8"	34-3/8"	40"	46-1/4"	52-1/2"	58-1/8"	64-3/8"
	(619)	(715)	(873)	(1016)	(1175)	(1334)	(1476)	(1635)
C	3-1/2"	1-1/2"	1-1/2"	2-1/8"	2-1/8"	2-1/8"	2-1/8"	2-1/8"
	(89)	(38)	(38)	(54)	(54)	(54)	(54)	(54)
Gauge	.135	.135	.135	.135	.135	.135	.135	.135
Wt. Lbs.	5	7	10	13.5	18	23	28.5	35
(Kg.)	(2.3)	(3.2)	(4.5)	(6.1)	(8.2)	(10.5)	(13)	(15.9)

FLAT OSHA GUARD

FINISHES:

Gray Electrocoat as standard.

OPTIONAL FINISHES:

- Air Dry Enamel to match.
- Acid Resistant coating (ARC, Epoxy).
- Air Dry Heresite.

Models:

LWBK/LMBK
LRBK/LNBK

▼ Propeller Fan Accessories - Hinged OSHA Guard — Model LXMBL

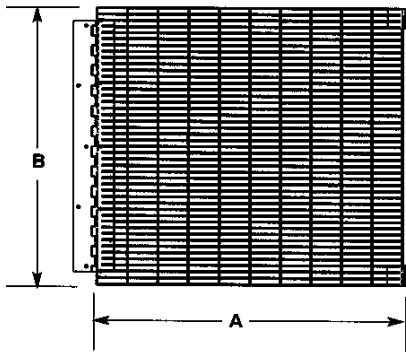
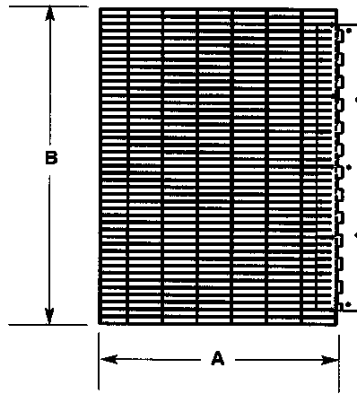
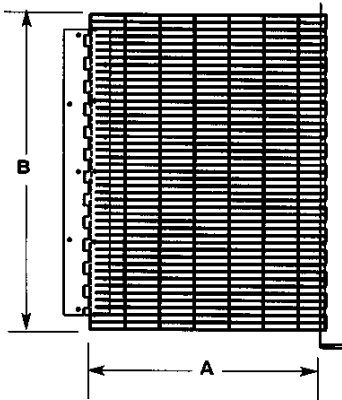

LOUVER EXTENSION:

FINISHES:

Gray Electrocoat as standard.

OPTIONAL FINISHES:

- Air Dry Enamel to match.
- Acid Resistant coating (ARC, Epoxy).
- Air Dry Heresite.

UNIT	DIMENSIONS and WEIGHT							
	20	24	30	36	42	48	54	60
A	26-1/4"	30-1/4"	36-1/4"	42-1/4"	48-1/4"	54-1/4"	60-1/4"	66-1/4"
	(667)	(768)	(921)	(1073)	(1226)	(1378)	(1530)	(1683)
B	24-3/8"	28-1/8"	34-3/8"	40"	46-1/4"	52-1/2"	58-1/8"	64-3/8"
	(619)	(715)	(873)	(1016)	(1175)	(1334)	(1476)	(1635)
Gauge	.135	.135	.135	.135	.135	.135	.135	.135
Wt. Lbs.	7	9	13	29	38	48	56	64
(Kg.)	(3.2)	(4.1)	(5.9)	(13.2)	(17.2)	(21.8)	(25.5)	(29.1)

Models:

LWBK/LMBK
LRBK/LNBK

▼ Propeller Fan Accessories - Air Foil Industrial Double Deflection Supply Grille — Model LXMBS

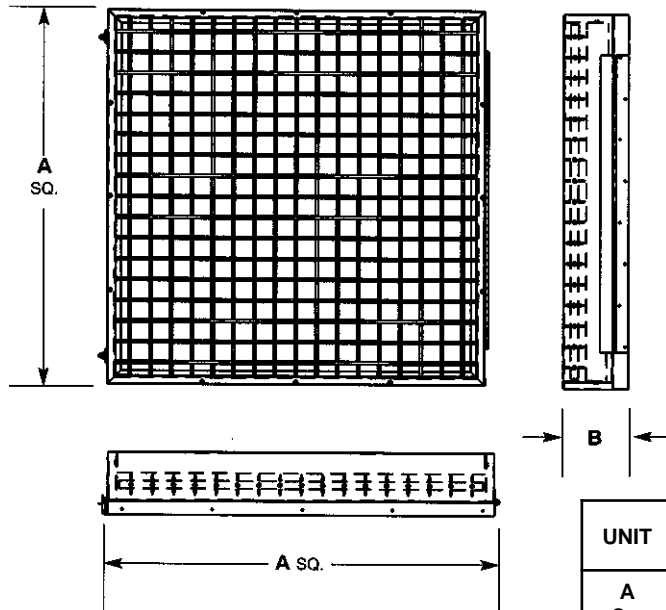

LOUVER EXTENSION:

FINISHES:

Gray Electrocoat as standard.

OPTIONAL FINISHES:

- Air Dry Enamel to match.
- Acid Resistant coating (ARC, Epoxy).
- Air Dry Heresite.

Models:

LWBK/LMBK
LRBK/LNBK

UNIT	DIMENSIONS and WEIGHT					
	20	24	30	36	42	48
A Sq.	26-11/16" (678)	30-11/16" (780)	36-11/16" (932)	42-11/16" (1084)	48-11/16" (1237)	54-11/16" (1389)
B	9" (229)	9" (229)	9" (229)	9" (229)	9" (229)	9" (229)
Gauge	16	16	16	16	16	16
Wt. Lbs. (Kg.)	50 (22.7)	50 (22.7)	75 (34.0)	94 (42.6)	115 (52.2)	138 (62.6)

▼ Propeller Fan Accessories - Motorsize Basket Guard for use with Mounting Collar — Model LXMBM

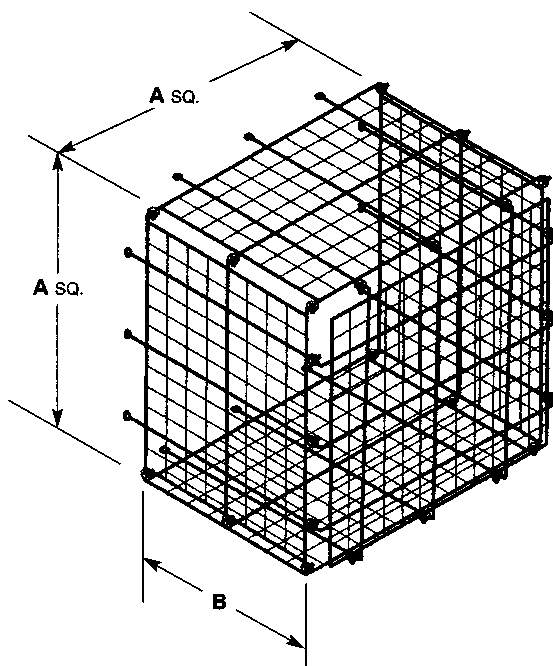

LOUVER EXTENSION:

FINISHES:

Gray Electrocoat as standard.

OPTIONAL FINISHES:

- Air Dry Enamel to match.
- Acid Resistant coating (ARC, Epoxy).
- Air Dry Heresite.

Models:

LWBK/LMBK
LRBK/LNBK

UNIT	DIMENSIONS and WEIGHT					
	20	24	30	36	42	48
A Sq.	26-1/4" (667)	30-1/4" (768)	36-1/4" (921)	42-1/4" (1073)	48-1/4" (1237)	54-1/4" (1378)
B	21-19/32" (548)	21-19/32" (548)	24-19/32" (625)	26-7/32" (625)	26-7/32" (625)	26-7/32" (625)
Gauge	1.135 & .188 wire	.135 & .188 wire	.135 & .188 wire	.135 & .188 wire	.135 & .188 wire	.135 & .188 wire
Wt. Lbs. (Kg.)	14 (6.4)	16 (7.3)	20 (9.1)	32 (14.5)	36 (16.3)	42 (19.1)

NOTE: Sizes 36 thru 48 features two piece back panel.

▼ Propeller Fan Accessories - Extruded Alum. Operable Louver— Model LXFBM

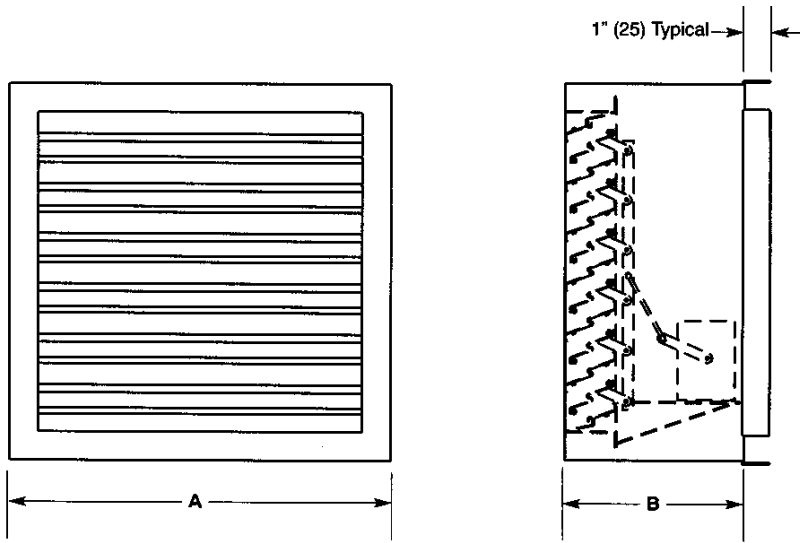

Models:
LWBK/LMBK
LRBK/LNBK

LOUVER:

FINISHES:

Mill Finish is standard.

OPTIONAL FINISHES:

- Air Dry Enamel to match.
- Acid Resistant coating.
- Air Dry Heresite.
- Natural Anodized
- Light Bronze Anodized.
- Medium Bronze Anodized.
- Dark Bronze Anodized.
- Black Anodized.

LOUVER EXTENSION:

FINISHES:

Gray Electrocoat as standard.

OPTIONAL FINISHES:

- Air Dry Enamel to match.
- Acid Resistant coating (ARC, Epoxy).
- Air Dry Heresite.

UNIT	DIMENSIONS						
	24	30	36	42	48	54	60
A Sq.	30-1/4" (768)	36-1/4" (920)	42-1/4" (1073)	48-1/4" (1225)	54-1/4" (1377)	60-1/4" (1530)	66-1/4" (1683)
B Dim.	14" (401)	14" (401)	14" (401)	14" (401)	14" (401)	14" (401)	14" (401)
Gauge	18 galv.	18 galv.	18 galv.	18 galv.	18 galv.	18 galv.	18 galv.

▼ Propeller Fan Accessories - Louver Extensions for Louver by Others — Model LXMBT

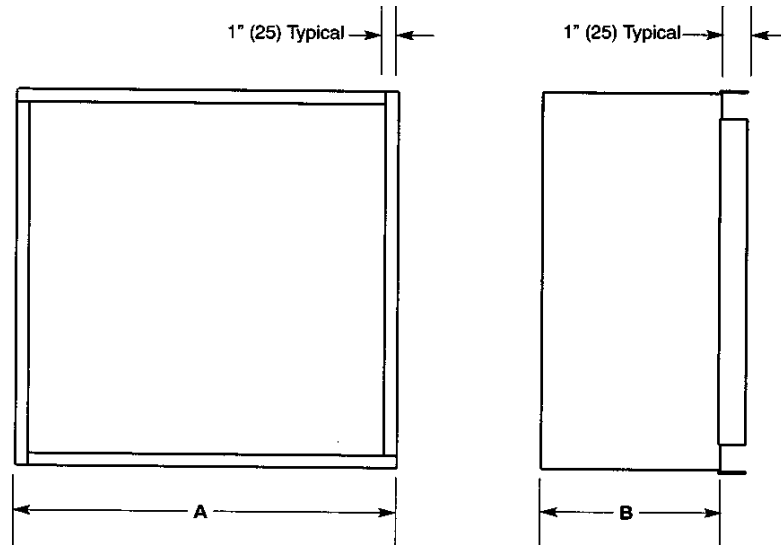

Models:
LWBK/LMBK
LRBK/LNBK

FINISHES:

Gray Electrocoat as standard.

OPTIONAL FINISHES:

- Air Dry Enamel to match.
- Acid Resistant coating (ARC, Epoxy).
- Air Dry Heresite.

UNIT	DIMENSIONS						
	24	30	36	42	48	54	60
A Sq.	30-1/4" (768)	36-1/4" (920)	42-1/4" (1073)	48-1/4" (1225)	54-1/4" (1377)	60-1/4" (1530)	66-1/4" (1683)
B Dim.	14" (401)	14" (401)	14" (401)	14" (401)	14" (401)	14" (401)	14" (401)
Gauge	18 galv.	18 galv.	18 galv.	18 galv.	18 galv.	18 galv.	18 galv.

▼ Propeller Fan Accessories - Weatherhood — Model LXMB G/H

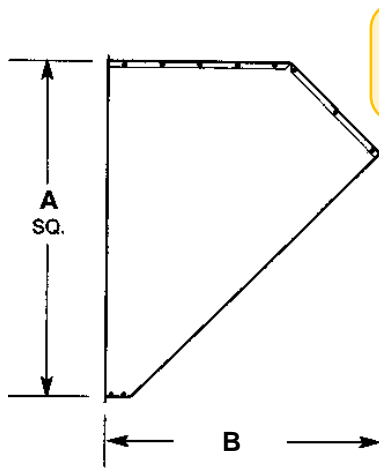

Models:
LWBK/LMBK
LRBK/LNBK

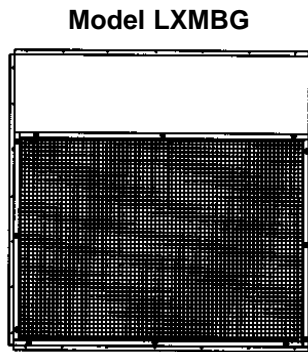

Unit with standard Birdscreen

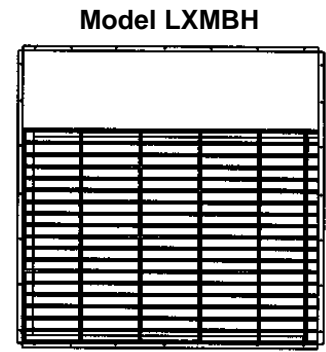

Unit with OSHA Guard

UNIT	DIMENSIONS and WEIGHT							
	20	24	30	36	42	48	54	60
A Sq.	26-1/4" (667)	30-1/4" (768)	36-1/4" (921)	42-1/4" (1073)	48-1/4" (1226)	54-1/4" (1378)	60-1/4" (1530)	66-1/4" (1683)
B	21-1/4" (540)	24-1/8" (613)	28-1/4" (718)	32-1/5" (826)	36-3/4" (1175)	41" (1041)	45-1/2" (1156)	44-3/4" (1635)
Gauge	18 galv.	18 galv.	18 galv.	18 galv.	18 galv.	18 galv.	18 galv.	18 galv.
Wt. Lbs. (Kg.)	22 (10.0)	29 (13.2)	40 (18.1)	53 (24.0)	67 (30.4)	84 (38.0)	107 (48.6)	127 (57.7)

LOUVER EXTENSION:

FINISHES:

Unit with standard Birdscreen: Gray Electrocoat as standard.

OPTIONAL FINISHES:

- Unit with OSHA Guard: Air Dry Enamel to match.
- Unit with OSHA Guard: Acid Resistant coating (ARC, Epoxy).
- Unit with OSHA Guard: Air Dry Heresite.

▼ Wall Box — Model LXMBW

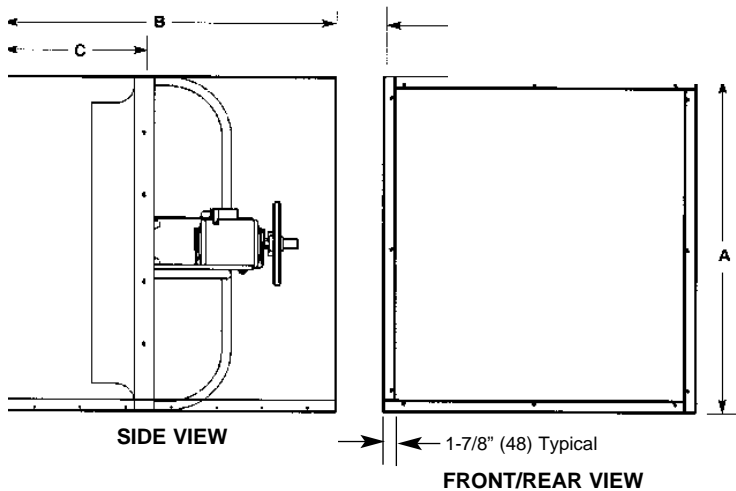

Models:
LWBK/LMBK
LRBK/LNBK

FINISHES:

Unit with standard Birdscreen: Gray Electrocoat as standard.

OPTIONAL FINISHES:

- Unit with OSHA Guard: Air Dry Enamel to match.
- Unit with OSHA Guard: Acid Resistant coating (ARC, Epoxy).
- Unit with OSHA Guard: Air Dry Heresite.

DIMENSIONS LISTED IN INCHES

Fan Size	A Sq. O. D.	B Length	C Panel Locate	Weight (lbs.)	Wall Opening
20	26-1/4	37-1/2	16-1/2	58	27-1/2
24	30-1/4	37-1/2	16-1/2	66	31-1/2
30	36-1/4	39-1/2	15-1/2	92	38
36	42-1/4	39-1/2	17-1/2	115	44
42	48-1/4	45-1/2	19-3/4	136	50
48	54-1/4	47-3/4	21-3/4	160	56
54	60-1/4	49-3/4	21-3/4	245	62
60	66-1/4	49-3/4	21-3/4	268	68

DIMENSIONS LISTED IN MILLIMETERS

Fan Size	A Sq. O. D.	B Length	C Panel Locate	Weight (Kg.)	Wall Opening
20	667	952	419	27	699
24	708	952	419	30	800
30	921	1003	394	42	965
36	1073	1003	445	52	1117
42	1226	1156	502	62	1270
48	1378	1213	552	73	1422
54	1531	1264	552	112	1575
60	1683	1264	552	122	1727

▼ Mounting Collar — Model LXMBD

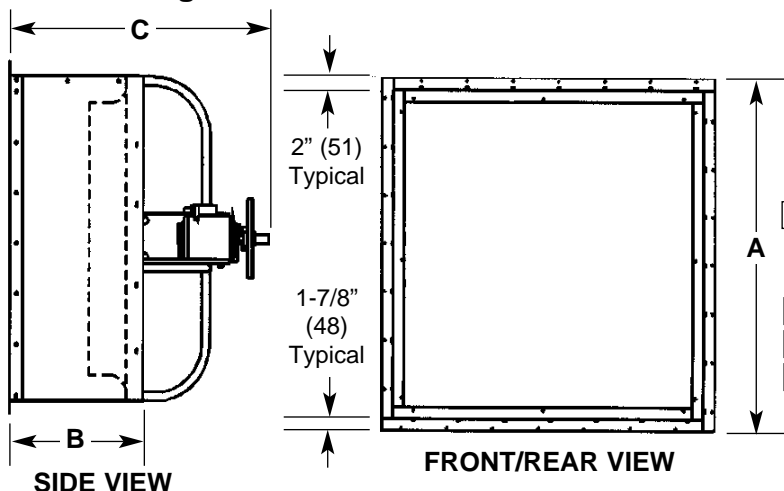

Models:
LWBK/LMBK
LRBK/LNBK

LOUVER EXTENSION:

FINISHES:

Gray Electrocoat as standard.

OPTIONAL FINISHES:

Air Dry Enamel to match.

Acid Resistant coating (ARC, Epoxy).

Air Dry Heresite.

DIMENSIONS LISTED IN INCHES

Fan Size	A Sq. O. D.	B Length	C Panel Locate	Weight (lbs.)	Wall Opening
20	26-1/4	17-1/2	35-3/8	32	27-1/2
24	30-1/4	17-1/2	35-3/8	37	31-1/2
30	36-1/4	17-1/2	38-3/8	44	38
36	42-1/4	18-1/2	41-3/8	53	44
42	48-1/4	20-3/4	43-5/8	67	50
48	54-1/4	22-3/4	45-5/8	82	56

DIMENSIONS LISTED IN MILLIMETERS

Fan Size	A Sq. O. D.	B Length	C Panel Locate	Weight (Kg.)	Wall Opening
20	688	444	898	15	699
24	768	444	898	17	800
30	921	444	974	20	965
36	1073	470	1051	24	1117
42	1226	527	1108	31	1270
48	1378	578	1159	37	1422

SpinMaster™ AC Micro Drive

Driven to be the Best... SpinMaster™ and SpinMaster™ Plus AC Drives



REGAL-BELOIT's SpinMaster™ AC drive is designed for the most demanding industrial applications from fans and pumps to conveyors and packaging equipment. The SpinMaster™ AC drive offers superior performance with smooth acceleration and deceleration, multiple presets, digital accuracy along with easy setup and operation.

The SpinMaster™ AC drive offers advanced features such as DC injection braking, current limit with frequency foldback, slip compensation, and multiple switching frequencies for quiet operation... all at an economical price.

The SpinMaster™ AC drive, depending on the drive series selected, has a horsepower range from 1/4 to 25 horsepower in 120 VAC, 208/240 VAC, 480 VAC and 575 VAC, single phase input, single or three phase input, and three phase inputs. A rugged convection cooled or heatsink fan cooled IP20 enclosure with finger safe terminals offers an advantage to the OEM or panelbuilder. An optional DIN rail mounting system provides additional flexibility in maximizing panel space.

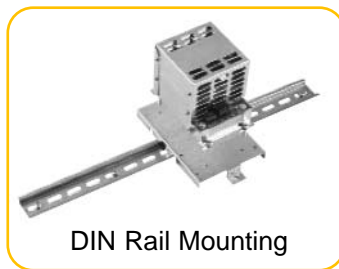

DIN Rail Mounting

When additional features are required such as load, speed or frequency scaling, analog output signals and communications, the full featured SpinMaster™ Plus offers exceptional performance at an affordable price. The SpinMaster™ Plus has eighteen isolated inputs and outputs including start, stop 0-10 VDC input, 4-20 mA input, 10 VDC supply for external potentiometer, and a 12 VDC supply for an external relay. Additional options include a 1000 Hz output frequency option for very high speed applications and PI control for process applications.

The SpinMaster™ AC drive performance matched with the industry's leading motors for unparalleled performance and one of the industry's longest warranties.



EPM Programmer

Ease of Programming Saves Time and Money...

Programming the SpinMaster™ AC drive is as simple as one, two, three. The drive can be programmed via the push buttons on the drive face, the EPM programmer, or via Techlink software.

The revolutionary EPM programmer provides full programming capability using "plug and play" techniques whereby the OEM can copy and download programs in seconds allowing for a fast program change. Over 30 drives programs can be stored at one time and programming is quick an easy using the 16 character English language format. The handheld battery powered EPM programmer allows the user to program the drive without power connection for increased productivity. The EPM programmer can be attached to a personal computer to upload and download drive programs using Techlink software.



When Performance Counts...

When high performance is required and reliability a must... turn to the industry leader in motion control applications... turn to REGAL-BELOIT... *"at the heart of what drives your world."*

SpinMaster™

Quality AC Micro Drive

Specifications	Features	
	SpinMaster™	SpinMaster™ Plus
Horsepower	1/3 - 5 Horsepower	1/4 - 25 Horsepower
Input Voltage	120 VAC, 208/240 VAC, 480 VAC	208/240 VAC, 480 VAC, 575 VAC
Phase	Single or Three Phase	Single or Three Phase
Carrier Frequency	4 - 10 kHz	4 - 10 kHz
Maximum Output Frequency	0 - 240 Hz	0 - 240 Hz
Programming Parameters	38	48
EPM Programmer	Yes (optional)	Yes (optional)
Push Buttons	3	3
Accel/Decel Time	0.1 - 990 seconds	0.1 - 3600 seconds
Control Voltage	12 VDC	12 VDC
Speed Scaling	User defined 0.0 - 6500	User defined 0.0 - 6500
Frequency Scaling	No	3.0 - 2000.0 Hz
Load Scaling	No	10 - 200%
High Speed Frequency	Yes (240 Hz)	Yes (240 Hz), optional 1000 Hz
Preset Speeds	7	7
Control I/O	Eleven isolated terminals	Eighteen isolated terminals
Communication	No	Modbus® Protocol
Display	Three digit	Three digit
Motor Overload Capacity	150% for 60 seconds	150% for 60 seconds
Programmable Inputs	Active high	Active low
Analog Outputs	None	2 (speed and load)
Digital Outputs	Current sourcing and relay	2 open collector
Torque Boost	0 - 30%	0 - 30%
Acceleration Boost	0 - 20%	0 - 20%
DC Injection Braking	0 - 30%	0 - 30%
Skip Frequency	2	2
PI Control	No	Yes (optional)
Cooling	Convection cooled	Convection, heatsink or fan
Enclosure	IP20	IP20
DIN Rail Mounting	Yes (optional)	Yes (optional)
Standards	UL and CSA	UL and CSA
Warranty	12/18 months	12/18 months

04 — Gray Baked Enamel:

Valspar® E-Coat (Vectrocoat - 300 Anodic Acrylic) — De-ionized Water Base Electrocoat applied in a full submersion tank then baked at 420°F for 20 minutes. Electrocoat process is similar to electroplating, but differs in that organic resins (paint) are deposited instead of metal. Customized coating for performance and appearance. Average mil finish is 1-1.2. Available in white or gray, gloss rating of 56 to 60 degree meter, pencil hardness of H, corrosive resistant for 250 hours exposure to salt spray environment ASTM Method B-117 with 1/8" maximum creepage from score line. Excellent finish coating or base coat/prime coat. Accepts dry heat temperatures to 300°F (149°C).

14 — ARC Epoxy (Acid Resistant Coating):

ARC is a modified epoxy-polyamid coating. Designed to provide high build, it has been engineered to meet the requirements of general maintenance service. It meets all FDA and USDA toxicity requirements. ARC presents a smooth, chemical resistant finish that is easily cleaned and maintained. It produces a semi-gloss, self priming finish that has exceptional hardness and durability. ARC has an excellent abrasion resistance to falling sand, rubbing, cutting and a very good rating for impact. ARC has a good rating for flexibility, passing 1/2" (13) mandrel testing. Accepts dry heat continuously to 275°F (135°C) and withstands surges to tanks, piping and equipment in the chemical industry. Resists splash and spillage of most acids, alkalies and salts. Will not promote the growth of mildew, fungus and bacterial slime. Coating for marine use where ease of application is important and resistance to erosion by fresh or salt water is required. Standard color is gray, other colors are available upon request.

Chemical Resistance:

Excellent — Resists hydrochloric acid to 20%, sulfuric acid to 15%, nitric acid to 5%, chromic acid to 5%, sodium hydroxide to 50% and ammonia to 10%.

Excellent — Resists all oil, margarine, lactic acid to 85%, phosphoric acid to 85%, oleic acid or red oil, fresh fruit juices, blood and wastes.

Excellent — Resists alcohols, aliphatic and most aromatic solvents.

50 — Prime Coat:

Same as 04 finish, accepts over coating extremely well for field paint to match with added protection. Can be either white or gray color.

80/81 — Under Coat/Anti-Condensate Coating:

Nox-Rust® AC-524 is a firm film undercoating material formulated to provide corrosion protection, sound deadening and moisture sealing properties to the underside of highway trailers, bus bodies, vehicles, commercial HVAC equipment, among others. Nox-Rust® AC-524 is composed of an abrasive free asphalt based material, dispersed in a petroleum solvent to provide a homogenous mastic type compound. This products heavy consistency allows for it to surpass salt spray testing of 500 hours. Finished mil thickness is 4-8 mil, depending on the application per Federal Specification TT-C-520-B. This is applied to ferrous, no-ferrous and galvanized material. Coating is black in color and is used on the undersides of lids, gravity hoods, motor mount plates and curb caps.

90 — Air Dry Enamel (Specify Color Number Per Carnes Color Chart):

Oil based enamel, Rust Stop® is a rust preventive enamel that provides long lasting color and finish on metals and woods. Usage is for interior and exterior applications that require paint to match or standard colors (see Carnes Color Chart for standard color options). Finish coat is applied over a primer base, then is applied in a 2-3 coat spray application. Overall mil finish - total coating thickness 1.8 to 3.2 mil. 1 to 2 mil finish coat, 0.8-1.2 mil prime coat. Medium to high gloss finish with very little fade from UV and weathering. Can be used in areas with high levels of moisture and steam. Maximum dry heat temperature is 200°F (93°C).

93 — Air Dry Heresite (Standard Gray):

Heresite® VR-500 is an air dry phenolic formulated to permit application by brush, spray or roller. Properties are excellent durability, good adhesion, good film building characteristics and flexibility. This coating produces a hard corrosion resistant film which is good for exposure to splashes, spillage and fumes. Applications include, but not limited to, construction equipment, sewage disposal plant, ventilating systems, chemical plants, agricultural implementations and underground or underwater service. VR-500 Series coating accepts dry heat temperatures up to 200°F (93°C). Standard finish mil thickness - 2 to 5 mil, depending on the application requirements. Standard color is gray, other colors are available upon request.

Chemical Resistance Guide:

<u>Exposure:</u>	<u>Splash and Spillage:</u>	<u>Fumes:</u>
Acids (Dilute)	Good	Excellent
Alkalies (Dilute)	Good	Good
Solvents	Fair	Good
Inorganic Salts	Good	Excellent
Water	Good	Excellent

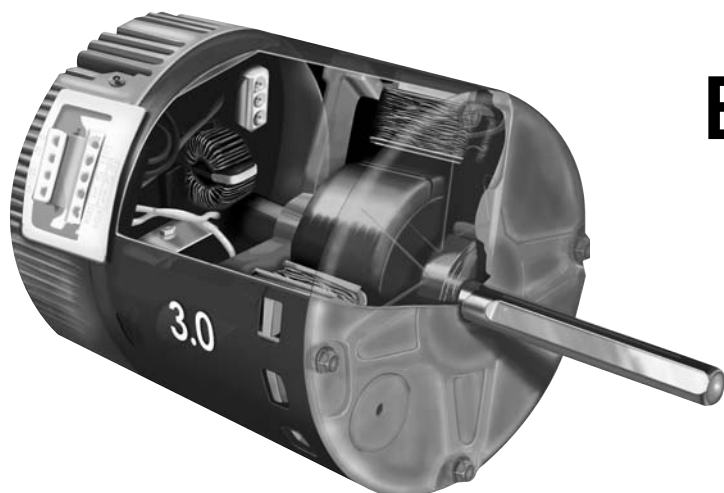

Eco-Drive ECM Motors

Eco-Drive (ECM) Benefits:

Verses PSC Direct Drive

- Up to 70% energy saving
- Maintain airflow + or - 5%
- Return of investment in as little as two years
- Lower sound levels than PSC motors
- Reliable Regal-Beloit motors
- Fan speed adjusted by small screw driver or by building automation system
- UL certified

Verses Belt Drive

- Low maintenance
- No energy loss due to belts & pulleys
- Easier setup and balancing
- More energy efficient

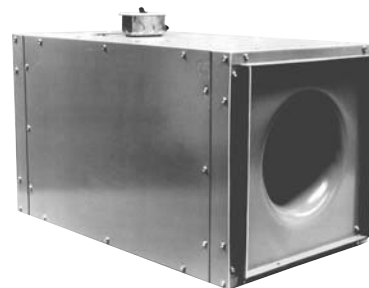

Example:

CFM	kWh Saved per Year	Utility Rate (\$/kWh)	Energy Savings per Year
At 1500 CFM	2500	0.10	\$255.00
		0.18	\$459.00
		0.26	\$663.00
At 1900 CFM	1400	0.10	\$140.00
		0.18	\$252.00
		0.26	\$364.00

Energy savings per year for a motor operating 6,000 hours per year

CFM	Percentage Energy Savings
1500	60%
1900	34%

Eco-Drive ECM — Direct Drive Only

Automatic Control Unit (ACU+)

If digital controls are being used on the project it is possible to control the speed of the ECM motor with a 0-10V control signal using the EVO ACU+ unit. The on/off signal is provided at a 24V input. Another option is to turn the motor on/off with a 0-1V signal and to use the 2-10V for speed control.

The EVO/ECM-ACU+ allows remote adjustment of the output from 0% to 100% of the programmed control range. A LED on the control continuously flashes out the flow index (percent of the programmed control range), so instruments are not required to read the value.

The "P" version provides ON/OFF control by switching the motor's "GO" control when the input signal drops below the 2 volt (4 mA) operating point.

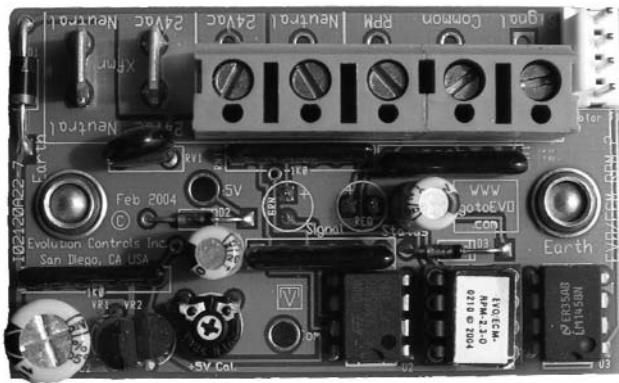

The green LED continuously indicates the flow index. After a pause, the LED flashes out the tens digit, then the units digit of a number (percent) between 1 and 99. Two extra long flashes indicate a flow index of 0%. Long flashes represent the tens digit, and short flashes represent the units digit. A flow index of 23%, flashes two longs and three shorts.

Specifications:

Power	NEC Class II Only 24 Vac ± 20% 50/60 Hz 4 W, 6 VA
Flow Index Adjustment RPM	270° rotation F Off-0-100 0-2000 RPM ± 2%
Outputs Go & Vspd ECM 2.3	24 Vdc @ 20 mA Set for Vspd Operation Set Status Flag (7) to RPM Thermal
Stability Operating	>0.01 %/°F 0°F to 130°F (-18°C to 55°C) Environment 10-80% rh
Connections	1/4 Tabs

Visual Control Unit (VCU)

The EVO/ECM-VCU control allows accurate manual adjustment and monitor of fans using Regal-Beloit ECM Motor.

The EVO/ECM-VCU features a 4 digit LED numerical display to allow easy reading in dark spaces. Watch the display and set the flow index with a screwdriver to adjust. Twenty seconds later, the display shows the motor RPM. Then, the display periodically alternates between the flow index and motor RPM.

The EVO/ECM-VCU may also be used where automation systems only turn the fan on or off.



Front of VCU

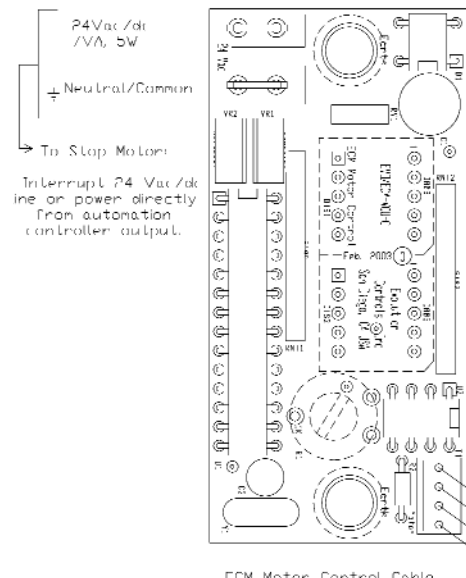

ECM Motor Control Cable

Back of VCU Control Unit